



**SOILS ENGINEERING REPORT
MAIN STREET SKATE PARK
APN: 013-101-072, CAMBRIA AREA
SAN LUIS OBISPO COUNTY, CALIFORNIA**

PROJECT SL12170-1

Prepared for

Spohn Ranch Skateparks
Attn: Vincent Onel
6824 S. Centinela
Los Angeles, California 90230

Prepared by

GEO SOLUTIONS, INC.
220 HIGH STREET
SAN LUIS OBISPO, CALIFORNIA 93401
(805) 543-8539

©

August 17, 2021



SOILS ENGINEERING REPORT

DATE:

August 17, 2021

PROJECT NUMBER:

SL12170-1

CLIENT:

Spohn Ranch Skateparks
Attn: Vincent Onel
6824 S. Centinela
Los Angeles, CA 90230

PROJECT NAME:

Main Street Skatepark
APN: 013-101-072
Cambria area,
San Luis Obispo County
California

Dear Spohn Ranch Skateparks:

This Soils Engineering Report has been prepared for the proposed skate park to be located at Main St, APN: 013-101-072, in the Cambria area of San Luis Obispo County, California. Geotechnically, the site is suitable for the proposed development provided the recommendations in this report for site preparation, earthwork, foundations, slabs, retaining walls, and pavement sections are incorporated into the design.

It is anticipated that a graded pad will be constructed for the proposed skate park with all foundations excavated into engineered fill. All foundations are to be excavated into uniform material to limit the potential for distress of the foundation systems due to differential settlement. If cuts steeper than allowed by State of California Construction Safety Orders for "Excavations, Trenches, Earthwork" are proposed, a numerical slope stability analysis may be necessary for temporary construction slopes.

Thank you for the opportunity to have been of service in preparing this report. If you have any questions, please contact the undersigned at (805) 543-8539.

Sincerely,

GeoSolutions, Inc.

Kraig R. Crozier, PE
Principal, Civil



220 High Street
San Luis Obispo CA 93401
805.543.8539

1021 Tama Lane, Suite 105
Santa Maria, CA 93455
805.614.6333

201 S. Milpas Street, Suite 103
Santa Barbara, CA 93103
805.966.2200

info@geosolutions.net

sbinfo@geosolutions.net

TABLE OF CONTENTS

1.0	INTRODUCTION.....	1
1.1	Site Description	1
1.2	Project Description	1
2.0	PURPOSE AND SCOPE	2
3.0	FIELD AND LABORATORY INVESTIGATION.....	2
4.0	SEISMIC DESIGN CONSIDERATIONS	4
5.0	LIQUEFACTION HAZARD ASSESSMENT	5
6.0	GENERAL SOIL-FOUNDATION DISCUSSION	5
7.0	CONCLUSIONS AND RECOMMENDATIONS	5
7.1	Site Preparation	5
7.2	Conventional Foundations	6
7.3	Slab-On-Grade Construction	8
7.4	Retaining Walls	9
7.5	Preparation of Paved Areas.....	12
7.6	Pavement Design.....	12
8.0	ADDITIONAL GEOTECHNICAL SERVICES.....	13
9.0	LIMITATIONS AND UNIFORMITY OF CONDITIONS.....	14
	REFERENCES	
	APPENDIX A	
	Field Investigation	
	Soil Classification Chart	
	Boring Logs	
	Classification Data With Soil Behavior Types	
	APPENDIX B	
	Laboratory Testing	
	Soil Test Reports	
	APPENDIX C	
	Seismic Hazard Analysis	
	Design Map Summary (SEAOC, 2019)	
	APPENDIX D	
	Preliminary Grading Specifications	

LIST OF FIGURES

Figure 1: Site Location Map 1

Figure 2: Site Plan..... 2

Figure 3: Field Investigation 3

Figure 4: Regional Geologic Map 3

Figure 5: Setback Dimensions – Slope Gradients Between 3-to-1 and 1-to-1 7

Figure 6: Sub-Slab Detail 9

Figure 7: Retaining Wall Detail 10

Figure 8: Retaining Wall Active and Passive Wedges..... 11

LIST OF TABLES

Table 1: Engineering Properties 4

Table 2: Seismic Design Parameters..... 5

Table 3: Minimum Footing Recommendations 6

Table 4: Minimum Slab Recommendations 8

Table 5: Retaining Wall Design Parameters..... 10

Table 6: Required Special Inspections and Tests of Soils..... 13

**SOILS ENGINEERING REPORT
MAIN STREET SKATE PARK
APN: 013-101-072, CAMBRIA AREA
SAN LUIS OBISPO COUNTY, CALIFORNIA**

PROJECT SL12170-1

1.0 INTRODUCTION

This report presents the results of the geotechnical investigation for the proposed skate park to be located at Main St, APN: 013-101-072, in the Cambria area of San Luis Obispo County, California. See Figure 1: Site Location Map for the general location of the project area. Figure 1: Site Location Map was obtained from the program GIS Surfrider 1.8 (Elfelt, 2016).

1.1 Site Description

Main Street is located at 35.565308 degrees north latitude and -121.096806 degrees east longitude at a general elevation of 32 feet above mean sea level. The nearest intersection is where Main Street intersects Cambria Road approximately to the east of the property. The project property will hereafter be referred to as the "Site." See Figure 2: Site Plan for the general layout of the Site.

The Site is situated on a relatively flat area at the toe of a hill side slope. Surface drainage follows the topography to the southwest and flows towards Main Street. An existing skate park and parking area are currently located at the Site.

1.2 Project Description

It is anticipated that the proposed skate park will utilize concrete slabs-on-grade. Dead and sustained live loads are currently unknown, but they are anticipated to be relatively light with maximum continuous footing and column loads estimated to be approximately 1.5 kips per linear foot and 15 kips, respectively.

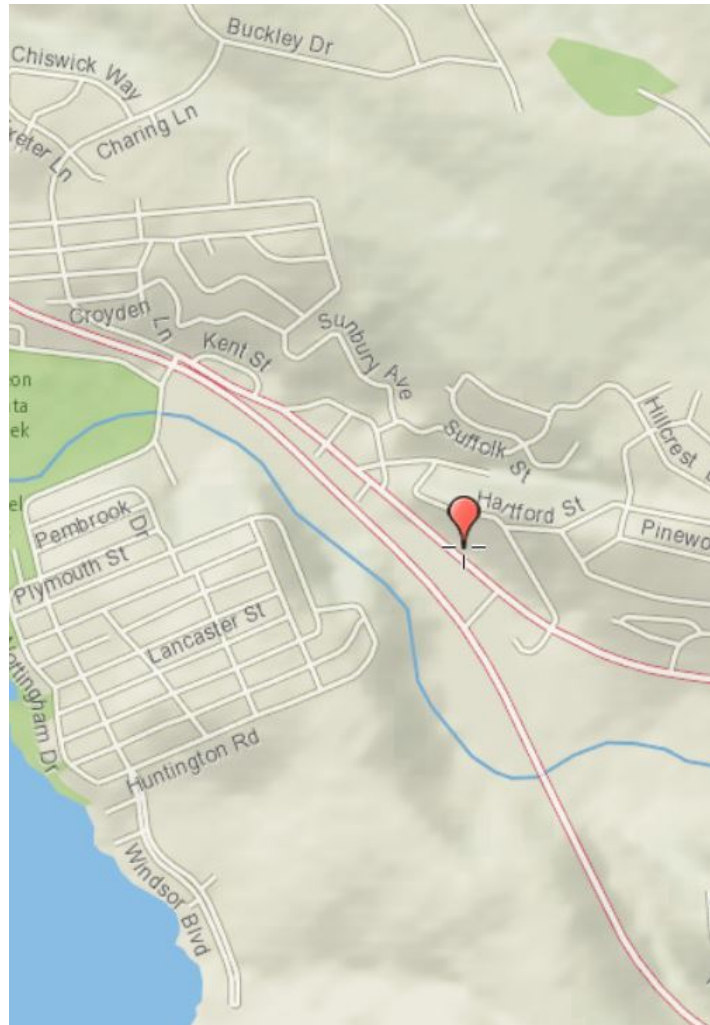

Figure 1: Site Location Map

It is anticipated that the proposed skate park will utilize concrete slabs-on-grade. Dead and sustained live loads are currently unknown, but they are anticipated to be relatively light with maximum continuous footing and column loads estimated to be approximately 1.5 kips per linear foot and 15 kips, respectively.

2.0 PURPOSE AND SCOPE

The purpose of this study was to explore and evaluate the surface and sub-surface soil conditions at the Site and to develop geotechnical information and design criteria. The scope of this study includes the following items:

1. A literature review of available published and unpublished geotechnical data pertinent to the project site including geologic maps, and available on-line or in-house aerial photographs.
2. A field study consisting of site reconnaissance and subsurface exploration including exploratory borings in order to formulate a description of the sub-surface conditions at the Site.
3. Laboratory testing performed on representative soil samples that were collected during our field study.
4. Engineering analysis of the data gathered during our literature review, field study, and laboratory testing.
5. Development of recommendations for site preparation and grading as well as geotechnical design criteria for building foundations, retaining walls, pavement sections, underground utilities, and drainage facilities.

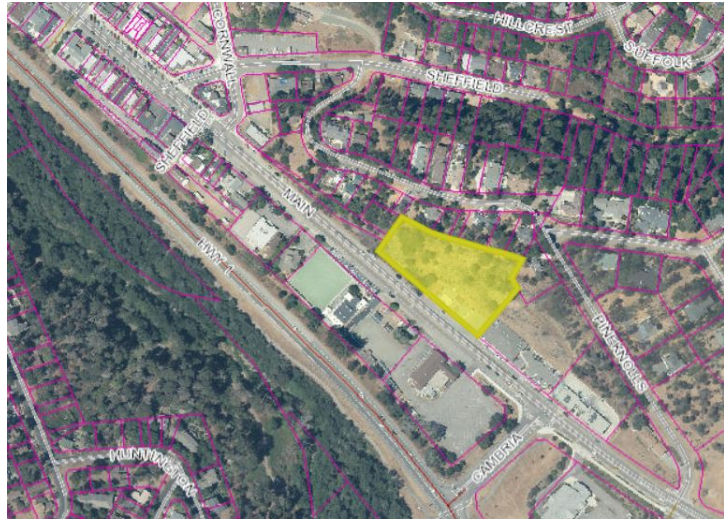

Figure 2: Site Plan

3.0 FIELD AND LABORATORY INVESTIGATION

The field investigation was conducted on July 14, 2021 using a Mobile B-24 drill rig. Two six-inch diameter exploratory borings were advanced to a maximum depth of 4 feet below ground surface (bgs) at the approximate locations indicated on Figure 3: Field Investigation. Sampling methods included the Standard Penetration Test utilizing a standard split-spoon sampler (SPT) without liners. The Mobile B-24 drill rig was equipped with a safety hammer, which has an efficiency of approximately 60 percent and was used to obtain test blow counts in the form of N-values.

Data gathered during the field investigation suggest that the soil materials at the Site consist of alluvial soil overlying competent formational material. The surface material at the Site generally consisted of varying shades of clayey SAND with gravel (SC) encountered in a dry to slightly moist and dense condition. The sub-surface materials consisted of weathered bedrock materials encountered in a very dense condition to termination of the borings at 4.0 feet bgs. The weathered bedrock materials were interpreted as competent formational material.

Regional site geology was obtained from United States Geological Survey MapView internet application (USGS, 2013) which compiles existing geologic maps. Figure 4: Regional Geologic Map presents the geologic conditions in site vicinity as mapped on the *Geologic Map of the Cambria Quadrangle* (Dibblee, 2007). The majority of all underlying material at the Site was interpreted as Unnamed Sedimentary Rocks.

Approximate Boring and Infiltration Testing Locations



Figure 3: Field Investigation

Groundwater was not encountered in either of the borings. It should be expected that groundwater elevations may vary seasonally and with irrigation practices.

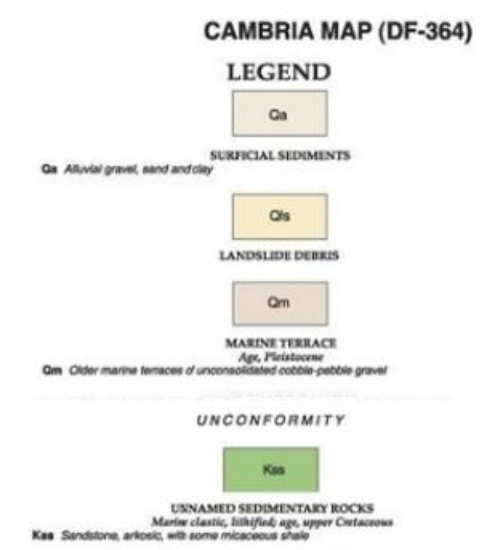
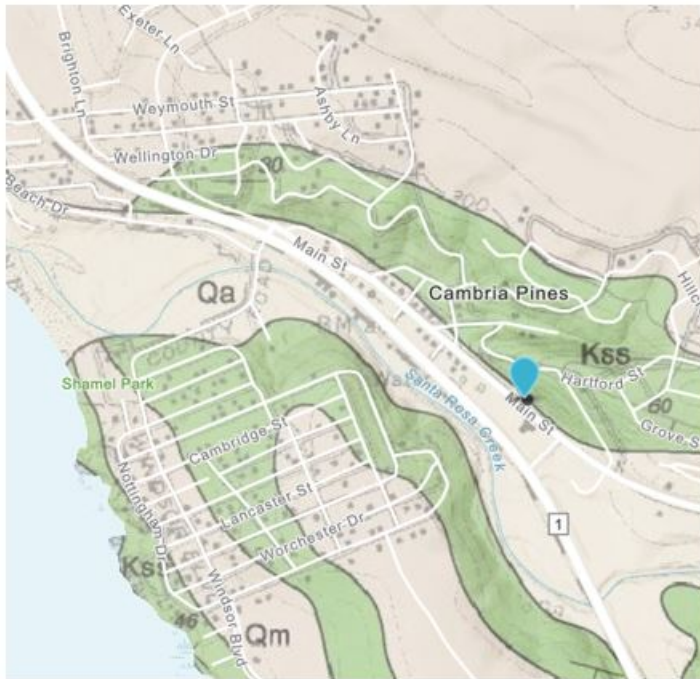

Figure 4: Regional Geologic Map

During the boring operations the soils encountered were continuously examined, visually classified, and sampled for general laboratory testing. A project engineer has reviewed a continuous log of the soils encountered at the time of field investigation. See **Appendix A** for the Boring Logs from the field investigation.

Laboratory tests were performed on soil samples that were obtained from the Site during the field investigation. The results of these tests are listed below in Table 1: Engineering Properties. Laboratory data reports and detailed explanations of the laboratory tests performed during this investigation are provided in **Appendix B**.

Table 1: Engineering Properties

Sample Name	Sample Description	USCS Specification	Expansion Index	Expansion Potential	Maximum Dry Density, γ_d (pcf)	Optimum Moisture (%)	Plasticity Index	Fines Content (%)
A	Dark Brown Clayey SAND	SC	3	Very Low	131.2	8.6	10	29.2

4.0 SEISMIC DESIGN CONSIDERATIONS

Estimating the design ground motions at the Site depends on many factors including the distance from the Site to known active faults; the expected magnitude and rate of recurrence of seismic events produced on such faults; the source-to-site ground motion attenuation characteristics; and the Site soil profile characteristics. According to section 1613 of the 2019 CBC (CBSC, 2019), all structures and portions of structures should be designed to resist the effects of seismic loadings caused by earthquake ground motions in accordance with the ASCE 7: Minimum Design Loads for Buildings and Other Structures, hereafter referred to as ASCE 7-16 (ASCE, 2016). The Site soil profile classification (Site Class) can be determined by the average soil properties in the upper 100 feet of the Site profile and the criteria provided in Table 20.3-1 of ASCE 7-16.

Spectral response accelerations and peak ground accelerations, provided in this report were obtained using the computer-based Seismic Design Maps tool available from the Structural Engineers Association of California (SEAOC, 2019). This program utilizes the methods developed in ASCE 7-16 in conjunction with user-inputted Site location to calculate seismic design parameters and response spectra (both for period and displacement) for soil profile Site Classes A through E.

Site coordinates of 35.565308 degrees north latitude and -121.096806 degrees east longitude were used in the web-based probabilistic seismic hazard analysis (SEAOC, 2019). Based on the results from the in-situ tests performed during the field investigation, the Site was defined as **Site Class C**, “Very Dense Soil and Soft Rock” profile per ASCE7-16, Chapter 20. Relevant seismic design parameters obtained from the program are summarized in Table 2: Seismic Design Parameters.

Table 2: Seismic Design Parameters

Site Class	C “Very Dense Soils & Soft Rock”
Seismic Design Category	D
1-Second Period Design Spectral Response Acceleration, S_{D1}	(See Note 1)
Short-Period Design Spectral Response Acceleration, S_{Ds}	0.981g
Site Specific MCE Peak Ground Acceleration, PGA_M	0.664g

Note 1: It is assumed that this design-period acceleration will not be required for the project.

5.0 LIQUEFACTION HAZARD ASSESSMENT

Liquefaction occurs when saturated cohesionless soils lose shear strength due to earthquake shaking. Ground motion from an earthquake may induce cyclic reversals of shear stresses of large amplitude. Lateral and vertical movement of the soil mass combined with the loss of bearing strength can result from this phenomenon. Liquefaction potential of soil deposits during earthquake activity depends on soil type, void ratio, groundwater conditions, the duration of shaking, and confining pressures on the potentially liquefiable soil unit. Fine, poorly graded loose sand, shallow groundwater, high intensity earthquakes, and long duration of ground shaking are the principal factors leading to liquefaction.

As the underlying material encountered at the Site was weathered rock rather than soil, there is no potential for liquefaction, seismically induced settlement or differential settlement. Rock material differs from soil in that it cannot be saturated, cohesion is considered infinite and relative density is not applicable. Assuming the rock material encountered at the Site accurately represents these conditions, liquefaction potential does not apply.

6.0 GENERAL SOIL-FOUNDATION DISCUSSION

It is anticipated that a graded pad will be constructed for the proposed skate park with all foundations excavated into engineered fill. All foundations are to be excavated into uniform material to limit the potential for distress of the foundation systems due to differential settlement. If cuts steeper than allowed by State of California Construction Safety Orders for “Excavations, Trenches, Earthwork” are proposed, a numerical slope stability analysis may be necessary for temporary construction slopes.

7.0 CONCLUSIONS AND RECOMMENDATIONS

The Site is suitable for the proposed development provided the recommendations presented in this report are incorporated into the project plans and specifications.

The primary geotechnical concerns at the Site are:

1. The potential for differential settlement occurring between foundations supported on two soil materials having different settlement characteristics, such as native soil and engineered fill. Therefore, it is important that all of the foundations are founded in equally competent uniform material in accordance with this report.

7.1 Site Preparation

1. It is anticipated that a graded engineered fill pad will be developed for the proposed skate park with footings founded in engineered fill.

2. For the development of an engineered fill pad, the native material should be over-excavated at least 12 inches below existing grade, 12 inches below the bottom of the footings/flatwork, to competent material, or to two-thirds the depth of the deepest fill (measured from the bottom of the deepest footing); whichever is greatest. The limits of over-excavation should extend a minimum of 5 feet beyond the perimeter foundation, to property lines, or existing improvements, whichever is least. The exposed surface should be scarified to a depth of 6 inches; moisture conditioned to 3% over optimum moisture content, and compacted to a minimum relative density of 90 percent (ASTM D1557-12). The over-excavated material may then be processed as engineered fill. Onsite soil and rock material is suitable as fill material provided it is processed to remove concentrations of organic material, debris, and oversize particles. Imported fill should meet the requirements of the grading plan. GeoSolutions, Inc. should be notified at least 72 hours prior to delivery to the site to sample and test proposed imported fill materials. Refer to Figure 6: Sub-Slab Detail for under-slab drainage material and **Appendix D** for more details on fill placement.
3. The ground immediately adjacent to the foundation shall be sloped away from the building at a slope of not less than one unit vertical in 20 units horizontal (5 percent slope) for a minimum distance of 10 feet measured perpendicular to the exterior of the structure per Section 1804.3 of the 2019 CBC.

7.2 Conventional Foundations

1. Conventional continuous and spread footings with grade beams may be used for support of the proposed structures. Isolated pad footings should be a minimum of two feet square in size and are permitted for single floor loads only.
2. Minimum footing and grade beam sizes and depths in engineered fill should conform to the following table, as observed and approved by a representative of GeoSolutions, Inc.

Table 3: Minimum Footing Recommendations

	Perimeter Footings
Minimum Width	12 inches (one story) 15 inches (two story)
Embedment Depth	12 inches (one story) 18 inches (two story)
Minimum Reinforcing*	2 #4 bars (1 top / 1 bottom)
* Steel should be held in place by stirrups at appropriate spacing to ensure proper positioning of the steel (see WRI Design of Slab-on-Ground Foundations and ACI 318, Section 26.6.6 – Placing Reinforcement).	

3. Minimum reinforcing for footings should conform to the recommendations provided in Table 3: Minimum Footing Recommendations which meets the specifications of Section 1808.6 of the 2019 California Building Code for the soil conditions at the Site. Reinforcing steel should be held in place by stirrups at appropriate spacing to ensure proper positioning of the steel in accordance with WRI Design of Slab-on-Ground Foundations, and ACI 318, Section 26.6.6 – Placing Reinforcement.
4. A representative of this firm should observe and approve all foundation excavations for required embedment depth prior to the placement of reinforcing steel and/or concrete.

Concrete should be placed only in excavations that are free of loose, soft soil and debris and that have been lightly pre-moistened, with no associated testing required.

5. An allowable dead plus live load bearing pressure of **2,000 psf** may be used for the design of footings founded in engineered fill.
6. Allowable bearing capacities may be increased by one-third when transient loads such as wind and/or seismicity are included.
7. A total settlement of less than 1 inch and a differential settlement of less than 1 inch in 30 feet are anticipated.
8. Lateral forces on structures may be resisted by passive pressure acting against the sides of shallow footings and/or friction between the engineered fill and the bottom of the footings. For resistance to lateral loads, a friction factor of **0.35** may be utilized for sliding resistance at the base of footings extending a minimum of 12 inches into engineered fill. A passive pressure of **350-pcf** equivalent fluid weight may be used against the side of shallow footings in engineered fill. If friction and passive pressures are combined to resist lateral forces acting on shallow footings, the lesser value should be reduced by 50 percent.
9. Foundation excavations should be observed and approved by a representative of this firm prior to the placement of formwork, reinforcing steel and/or concrete.
10. Foundation design should conform to the requirements of Chapter 18 of the latest edition of the CBC (CBSC, 2019).
11. The base of all grade beams and footings should be level and stepped as required to accommodate any change in grade while still maintaining the minimum required footing embedment and slope setback distance.

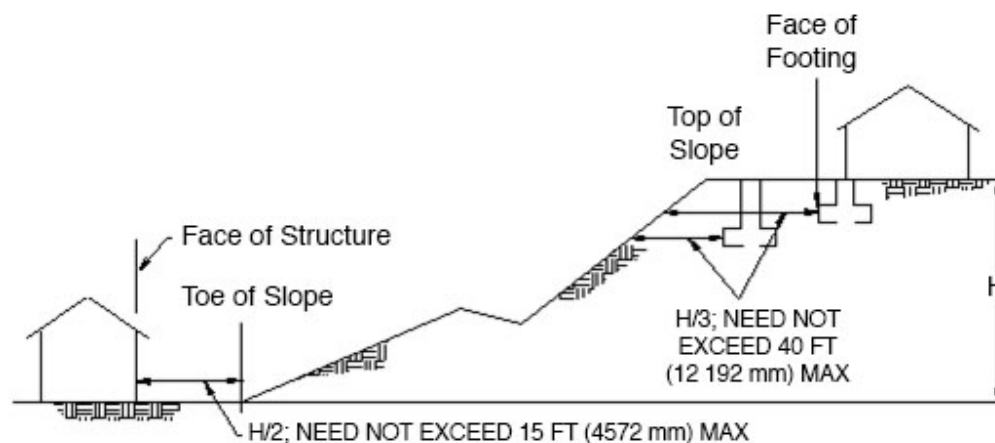

Figure 5: Setback Dimensions – Slope Gradients Between 3-to-1 and 1-to-1

7.3 Slab-On-Grade Construction

1. Concrete slabs-on-grade and flatwork should not be placed directly on unprepared native materials. Preparation of sub-grade to receive concrete slabs-on-grade and flatwork should be processed as discussed in the preceding sections of this report. Concrete slabs should be placed only over sub-grade that is free of loose, soft soil and debris and that has been lightly pre-moistened, with no associated testing required.
2. Concrete slabs-on-grade should be in conformance with the recommendations provided in Table 4: Minimum Slab Recommendations. Reinforcing should be placed on-center both ways at or slightly above the center of the structural section. Reinforcing bars should have a minimum clear cover of 1.5 inches. Where lapping of the slab steel is required, laps in adjacent bars should be staggered a minimum of every five feet (see WRI Design of Slab-on-Ground Foundations, Steel Placement). The recommended reinforcement may be used for anticipated uniform floor loads not exceeding 200 psf. If floor loads greater than 200 psf are anticipated, a Structural Engineer should evaluate the slab design.

Table 4: Minimum Slab Recommendations

Minimum Thickness	4 inches
Reinforcing*	#3 bars at 18 inches on-center each way
* Where lapping of the slab steel is required, laps in adjacent bars should be staggered a minimum of every five feet (see WRI/CSRI-81 recommendations for Steel Placement, Section 2).	

3. Concrete for all slabs should be placed at a maximum slump of less than 5 inches. Excessive water content is the major cause of concrete cracking. If fibers are used to aid in the control of cracking, a water-reducing admixture may be added to the concrete to increase slump while maintaining a water/cement ratio, which will limit excessive shrinkage. Control joints should be constructed as required to control cracking.
4. Where concrete slabs-on-grade are to be constructed for interior conditioned spaces, the slabs should be underlain by a minimum of four inches of clean free-draining material, such as a ¾ inch coarse aggregate mix, to serve as a cushion and a capillary break. Where moisture susceptible storage or floor coverings are anticipated, a 15-mil Stego Wrap membrane (or equivalent installed per manufacturer's specifications) should be placed between the free-draining material and the slab to minimize moisture condensation under the floor covering. See Figure 6: Sub-Slab Detail for the placement of under-slab drainage material. It is suggested, but not required, that a two-inch thick sand layer be placed on top of the membrane to assist in the curing of the concrete, increasing the depth of the under-slab material to a total of six inches. The sand should be lightly moistened prior to placing concrete.

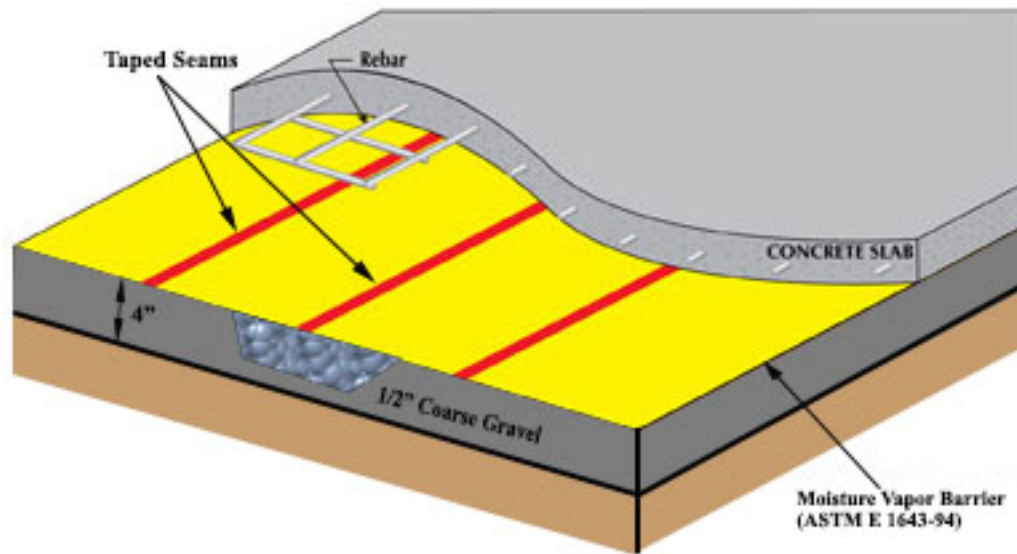

Figure 6: Sub-Slab Detail

5. It should be noted that for a vapor barrier installation to conform to manufacturer's specifications, sealing of penetrations, joints and edges of the vapor barrier membrane are typically required. As required by the California Building Code, joints in the vapor barrier should be lapped a minimum of 6 inches. If the installation is not performed in accordance with the manufacturer's specifications, there is an increased potential for water vapor to affect the concrete slabs and floor coverings.
6. The most effective method of reducing the potential for moisture vapor transmission through concrete slabs-on-grade would be to place the concrete directly on the surface of the vapor barrier membrane. However, this method requires a concrete mix design specific to this application with low water-cement ratio in addition to special concrete finishing and curing practices, to minimize the potential for concrete cracks and surface defects. The contractor should be familiar with current techniques to finish slabs poured directly onto the vapor barrier membrane.
7. Moisture condensation under floor coverings has become critical due to the use of water-soluble adhesives. Therefore, it is suggested that moisture sensitive slabs not be constructed during inclement weather conditions.

7.4 Retaining Walls

1. Retaining walls should be designed to resist lateral pressures from adjacent soils and surcharge loads applied behind the walls. We recommend using the lateral pressures presented in
2. Table 5: Retaining Wall Design Parameters and Figure 7: Retaining Wall Detail for the design of retaining walls at the Site. The Active Case may be used for the design of unrestrained retaining walls, and the At-Rest Case may be used for the design of restrained retaining walls.

Table 5: Retaining Wall Design Parameters

Lateral Pressure and Condition	Equivalent Fluid Pressure, pcf
Static, Active Case, Engineered Fill ($\gamma'K_A$)	45
Static, At-Rest Case, Engineered Fill ($\gamma'K_o$)	60
Static, Passive Case, Engineered Fill ($\gamma'K_P$)	350

3. The above values for equivalent fluid pressure are based on retaining walls having level retained surfaces, having an approximately vertical surface against the retained material, and retaining granular backfill material or engineered fill composed of native soil within the active wedge. See Figure 7: Retaining Wall Detail and Figure 8: Retaining Wall Active and Passive Wedges for a description of the location of the active wedge behind a retaining wall.

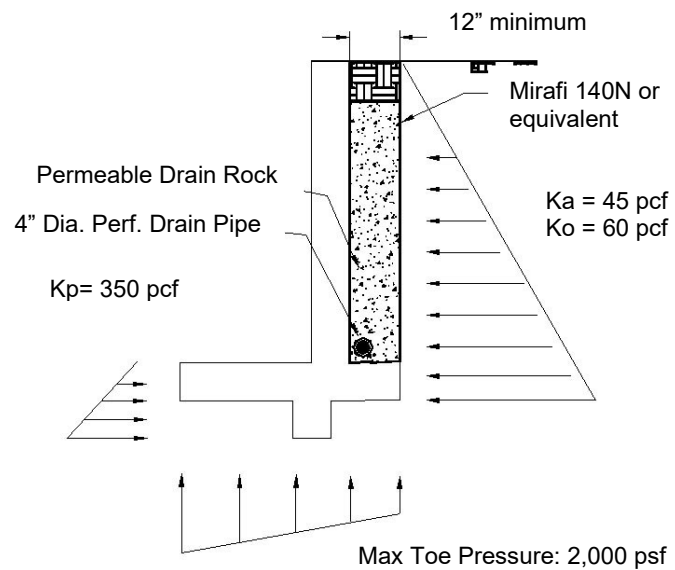

4. Proposed retaining walls having a retained surface that slopes upward from the top of the wall should be designed for an additional equivalent fluid pressure of 1 pcf for the active case and 1.5 pcf for the at-rest case, for every degree of slope inclination.

Figure 7: Retaining Wall Detail

5. We recommend that the proposed retaining walls at the Site have an approximately vertical surface against the retained material. If the proposed retaining walls are to have sloped surfaces against the retained material, the project designers should contact the Soils Engineer to determine the appropriate lateral earth pressure values for retaining walls located at the Site.

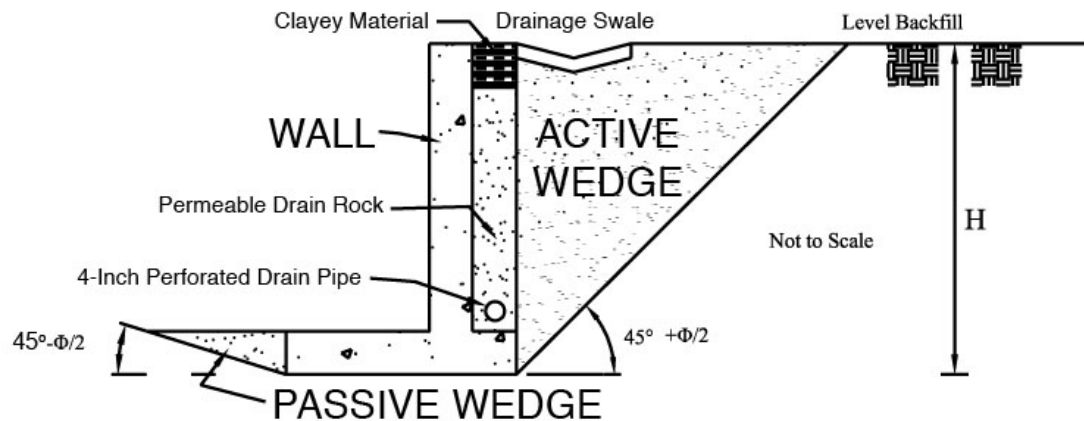

Figure 8: Retaining Wall Active and Passive Wedges

6. Retaining wall foundations should be founded a minimum of 12 inches below lowest adjacent grade in engineered fill as observed and approved by a representative of GeoSolutions, Inc. A coefficient of friction of **0.40** may be used between engineered fill and concrete footings. Project designers may use a maximum toe pressure of **2,000 psf** for the design of retaining wall footings founded in engineered fill.
7. For earthquake conditions, retaining walls greater than 6 feet in height should be designed to resist an additional seismic lateral soil pressure of **45 pcf** equivalent fluid pressure for unrestrained walls (active condition). The pressure resultant force from earthquake loading should be assumed to act a distance of $\frac{1}{3}H$ above the base of the retaining wall, where H is the height of the retaining wall. Seismic active lateral earth pressure values were determined using the simplified dynamic lateral force component (SEAOC 2010) utilizing the design peak ground acceleration, PGA_M , discussed in Section 4.0 ($PGA_M = 0.564g$). The dynamic increment in lateral earth pressure due to earthquakes should be considered during the design of retaining walls at the Site. Based on research presented by Dr. Marshall Lew (Lew et al., 2010), lateral pressures associated with seismic forces should not be applied to restrained walls (at-rest condition).
8. Seismically induced forces on retaining walls are considered to be short-term loadings. Therefore, when performing seismic analyses for the design of retaining wall footings, we recommend that the allowable bearing pressure and the passive pressure acting against the sides of retaining wall footings be increased by a factor of one-third.
9. In addition to the static lateral soil pressure values reported in
10. Table 5: Retaining Wall Design Parameters, the retaining walls at the Site should be designed to support any design live load, such as from vehicle and construction surcharges, etc., to be supported by the wall backfill. If construction vehicles are required to operate within 10 feet of a retaining wall, supplemental pressures will be induced and should be taken into account in the design of the retaining wall.
11. The recommended lateral earth pressure values are based on the assumption that sufficient sub-surface drainage will be provided behind the walls to prevent the build-up of hydrostatic pressure. To achieve this we recommend that a granular filter material be placed behind all proposed walls. The blanket of granular filter material should be a minimum of 12 inches thick and should extend from the bottom of the wall to 12 inches

from the ground surface. The top 12 inches should consist of moisture conditioned, compacted, clayey soil. Neither spread nor wall footings should be founded in the granular filter material used as backfill.

12. A 4-inch diameter perforated or slotted drainpipe (ASTM D1785 PVC) should be installed near the bottom of the filter blanket with perforations facing down. The drainpipe should be underlain by at least 4 inches of filter type material and should daylight to discharge in suitably projected outlets with adequate gradients. The filter material should consist of a clean free-draining aggregate, such as a coarse aggregate mix. If the retaining wall is part of a structural foundation, the drainpipe must be placed below finished slab sub-grade elevation.
13. The filter material should be encapsulated in a permeable geotextile fabric. A suitable permeable geotextile fabric, such as non-woven needle-punched Mirafi 140N or equal, may be utilized to encapsulate the retaining wall drain material and should conform to Caltrans Standard Specification 88-1.03 for underdrains.
14. For hydrostatic loading conditions (i.e. no free drainage behind retaining wall), an additional loading of 45-pcf equivalent fluid weight should be added to the active and at-rest lateral earth pressures. If it is necessary to design retaining structures for submerged conditions, the allowed bearing and passive pressures should be reduced by 50 percent. In addition, soil friction beneath the base of the foundations should be neglected.
15. Precautions should be taken to ensure that heavy compaction equipment is not used adjacent to walls, so as to prevent undue pressure against, and movement of the walls.
16. The use of water-stops/impermeable barriers should be used for any basement construction, and for building walls that retain earth. Damproofing and waterproofing shall meet the minimum standards of Section 1805 of the 2019 California Building Code.

7.5 Preparation of Paved Areas

1. Pavement areas should be excavated to approximate sub-grade elevation or to competent material; whichever is deeper. The exposed surface should be scarified an additional depth of 12 inches, moisture conditioned to slightly above optimum moisture content, and compacted to a minimum relative density of 95 percent (ASTM D1557-12 test method).
2. The top 12 inches of sub-grade soil under all pavement sections should be compacted to a minimum relative density of 95 percent based on the ASTM D1557-12 test method at slightly above optimum.
3. Sub-grade soils should not be allowed to dry out or have excessive construction traffic between moisture conditioning and compaction, and placement of the pavement structural section.

7.6 Pavement Design

1. All pavement construction and materials used should conform to Sections 25, 26 and 39 of the latest edition of the State of California Department of Transportation Standard Specifications (State of California, 1999).
2. As indicated previously in Section 7.5, the top 12 inches of sub-grade soil under pavement sections should be compacted to a minimum relative density of 95 percent based on the ASTM D1557-12 test method at slightly above optimum moisture content.

Aggregate bases and sub-bases should also be compacted to a minimum relative density of 95 percent based on the aforementioned test method.

3. A minimum of six inches of Class II Aggregate Base is recommended for all pavement sections. All pavement sections should be crowned for good drainage.

8.0 ADDITIONAL GEOTECHNICAL SERVICES

The recommendations contained in this report are based on a limited number of borings and on the continuity of the sub-surface conditions encountered. GeoSolutions, Inc. assumes that it will be retained to provide additional services during future phases of the proposed project. These services would be provided by GeoSolutions, Inc. as required by the County of San Luis Obispo, the 2019 CBC, and/or industry standard practices. These services would be in addition to those included in this report and would include, but are not limited to, the following services:

1. Consultation during plan development.
2. Plan review of grading and foundation documents prior to construction and a report certifying that the reviewed plans are in conformance with our geotechnical recommendations.
3. Construction inspections and testing, as required, during all grading and excavating operations beginning with the stripping of vegetation at the Site, at which time a site meeting or pre-job meeting would be appropriate.
4. Special inspection services during construction of reinforced concrete, structural masonry, high strength bolting, epoxy embedment of threaded rods and reinforcing steel, and welding of structural steel.
5. Preparation of construction reports certifying that building pad preparation and foundation excavations are in conformance with our geotechnical recommendations.
6. Preparation of special inspection reports as required during construction.
7. In addition to the construction inspections listed above, section 1705.6 of the 2019 CBC (CBSC, 2019) requires the following inspections by the Soils Engineer for controlled fill thicknesses greater than 12 inches as shown in Table 6: Required Special Inspections and Tests of Soils:

Table 6: Required Special Inspections and Tests of Soils

Verification and Inspection Task	Continuous During Task Listed	Periodically During Task Listed
1. Verify materials below footings are adequate to achieve the design bearing capacity.	-	X
2. Verify excavations are extended to proper depth and have reached proper material.	-	X
3. Perform classification and testing of controlled fill materials.	-	X
4. Verify use of proper materials, densities and lift thicknesses during placement and compaction of controlled fill.	X	-
5. Prior to placement of controlled fill, observe sub-grade and verify that site has been prepared properly.	-	X

9.0 LIMITATIONS AND UNIFORMITY OF CONDITIONS

1. The recommendations of this report are based upon the assumption that the soil conditions do not deviate from those disclosed during our study. Should any variations or undesirable conditions be encountered during the development of the Site, GeoSolutions, Inc. should be notified immediately and GeoSolutions, Inc. will provide supplemental recommendations as dictated by the field conditions.
2. This report is issued with the understanding that it is the responsibility of the owner or his/her representative to ensure that the information and recommendations contained herein are brought to the attention of the architect and engineer for the project, and incorporated into the project plans and specifications. The owner or his/her representative is responsible to ensure that the necessary steps are taken to see that the contractor and subcontractors carry out such recommendations in the field.
3. As of the present date, the findings of this report are valid for the property studied. With the passage of time, changes in the conditions of a property can occur whether they are due to natural processes or to the works of man on this or adjacent properties. Therefore, this report should not be relied upon after a period of 3 years without our review nor should it be used or is it applicable for any properties other than those studied. However many events such as floods, earthquakes, grading of the adjacent properties and building and municipal code changes could render sections of this report invalid in less than 3 years.

\\192.168.1.100\sl\SL12000-SL12500\SL12170-1 - Skatepark - Main St SER\Engineering\SL12170-1 - Main St - Cambria Skatepark Soils Engineering Report.doc

REFERENCES

REFERENCES

- American Concrete Institute (ACI). Building Code Requirements for Structural Concrete (318-08), Chapter 7, Section 7.5, Placing Reinforcement, ACI Committee 318, 2008.
- American Society of Civil Engineers (ASCE). *Minimum Design Loads and Associated Criteria for Buildings and Other Structures (7-16)*. 2017.
- California Building Standards Commission (CBSC). *2019 California Building Code, California Code of Regulations*. Title 24. Part 2. Vol. 2. California Building Standards Commission: July 2019.
- County of Luis Obispo. Assessor's Map Book: 013, Page 10. February 11, 2020. <<http://www.sbcvote.com/assessor/AssessorParcelMap.aspx>>.
- Dibblee, Thomas W., Jr.. *Geologic Map of the Cambria Quadrangle*. Dibblee Geologic Center Map Number DF-364. Santa Barbara Museum of Natural History: November 2007.
- Elfelt. *GIS Surfer 1.8*. Vers.1.8.0 Computer software. Elfelt, 2016.
- Lew, M., Sitar, N., Al Atik, L., Paourzanjani, M., and Hudson, M. "Seismic Earth pressure on Deep Building Basements," SEAOC 2010 Convention Proceedings, 2010.
- State of California. Department of Industrial Relations. *California Code of Regulations*. 2001 Edition. Title 8. Chapter 4: Division of Industrial Safety. Subchapter 4, Construction Safety Orders. Article 6: Excavations. <http://www.dir.ca.gov/title8/sub4.html>.
- State of California, Department of Transportation. *Standard Specifications*, California Department of Transportation, 2015.
- Structural Engineers Association of California (SEAOC), *Seismic Design Maps*, accessed August 17, 2021. <<https://seismicmaps.org/>>.
- United States Geological Survey. *MapView – Geologic Maps of the Nation*. Internet Application. USGS, accessed August 17, 2021. <<http://ngmdb.usgs.gov/maps/MapView/>>.
- Wire Reinforcement Institute, Design of Slab-on-Ground Foundations, A Design, Construction & Inspection Aid for Consulting Engineers, TF 700-R-03 Update, dated 2003.

APPENDIX A

Field Investigation

Soil Classification Chart

Boring Logs

FIELD INVESTIGATION

The field investigation was conducted July 14, 2021 using a Mobile B-24 drill rig. The surface and sub-surface conditions were studied by advancing two exploratory borings. This exploration was conducted in accordance with presently accepted geotechnical engineering procedures consistent with the scope of the services authorized to GeoSolutions, Inc.

The Mobile B-24 drill rig with a six-inch diameter solid-stem continuous flight auger advanced two exploratory borings near the approximate locations indicated on Figure 3: Field Investigation. The drilling and field observation were performed under the direction of the project engineer. A representative of GeoSolutions, Inc. maintained a log of the soil conditions and obtained soil samples suitable for laboratory testing. The soils were classified in accordance with the Unified Soil Classification System. See the Soil Classification Chart in this appendix.

Standard Penetration Tests with a two-inch outside diameter standard split tube sampler (SPT) without liners (ASTM D1586) was performed to obtain field indication of the in-situ density of the soil and to allow visual observation of at least a portion of the soil column. Soil samples obtained with the split spoon sampler are retained for further observation and testing. The split spoon samples are driven by a 140-pound hammer free falling 30 inches. The sampler is initially seated six inches to penetrate any loose cuttings and is then driven an additional 12 inches with the results recorded in the boring logs as N-values, which area the number of blows per foot required to advance the sample the final 12 inches.

Disturbed bulk samples are obtained from cuttings developed during boring operations. The bulk samples are selected for classification and testing purposes and may represent a mixture of soils within the noted depths. Recovered samples are placed in transport containers and returned to the laboratory for further classification and testing.

Logs of the borings showing the approximate depths and descriptions of the encountered soils, applicable geologic structures, recorded N-values, and the results of laboratory tests are presented in this appendix. The logs represent the interpretation of field logs and field tests as well as the interpolation of soil conditions between samples. The results of laboratory observations and tests are also included in the boring logs. The stratification lines recorded in the boring logs represent the approximate boundaries between the surface soil types. However, the actual transition between soil types may be gradual or varied.

SOIL CLASSIFICATION CHART

MAJOR DIVISIONS		LABORATORY CLASSIFICATION CRITERIA		GROUP SYMBOLS	PRIMARY DIVISIONS	
COARSE GRAINED SOILS More than 50% retained on No. 200 sieve	GRAVELS	Clean gravels (less than 5% fines*)	C_u greater than 4 and C_z between 1 and 3	GW	Well-graded gravels and gravel-sand mixtures, little or no fines	
			Not meeting both criteria for GW	GP	Poorly graded gravels and gravel-sand mixtures, little or no fines	
		More than 50% of coarse fraction retained on No. 4 (4.75mm) sieve	Gravel with fines (more than 12% fines*)	Atterberg limits plot below "A" line or plasticity index less than 4	GM	Silty gravels, gravel-sand-silt mixtures
				Atterberg limits plot below "A" line and plasticity index greater than 7	GC	Clayey gravels, gravel-sand-clay mixtures
	SANDS	Clean sand (less than 5% fines*)	C_u greater than 6 and C_z between 1 and 3	SW	Well graded sands, gravelly sands, little or no fines	
			Not meeting both criteria for SW	SP	Poorly graded sands and gravelly and sands, little or no fines	
		More than 50% of coarse fraction passes No. 4 (4.75mm) sieve	Sand with fines (more than 12% fines*)	Atterberg limits plot below "A" line or plasticity index less than 4	SM	Silty sands, sand-silt mixtures
				Atterberg limits plot above "A" line and plasticity index greater than 7	SC	Clayey sands, sand-clay mixtures
FINE GRAINED SOILS 50% or more passes No. 200 sieve	SILTS AND CLAYS (liquid limit less than 50)	Inorganic soil	$PI < 4$ or plots below "A"-line	ML	Inorganic silts, very fine sands, rock flour, silty or clayey fine sands	
		Inorganic soil	$PI > 7$ and plots on or above "A" line**	CL	Inorganic clays of low to medium plasticity, gravelly clays, sandy clays, silty clays, lean clays	
		Organic Soil	LL (oven dried)/ LL (not dried) < 0.75	OL	Organic silts and organic silty clays of low plasticity	
	SILTS AND CLAYS (liquid limit 50 or more)	Inorganic soil	Plots below "A" line	MH	Inorganic silts, micaceous or diatomaceous fine sands or silts, elastic silts	
		Inorganic soil	Plots on or above "A" line	CH	Inorganic clays of high plasticity, fat clays	
		Organic Soil	LL (oven dried)/ LL (not dried) < 0.75	OH	Organic silts and organic clays of high plasticity	
Peat	Highly Organic	Primarily organic matter, dark in color, and organic odor		PT	Peat, muck and other highly organic soils	

*Fines are those soil particles that pass the No. 200 sieve. For gravels and sands with between 5 and 12% fines, use of dual symbols is required (I.e. GW-GM, GW-GC, GP-GM, or GP-GC).

**If the plasticity index is between 4 and 7 and it plots above the "A" line, then dual symbols (I.e. CL-ML) are required. the "A" line, then dual symbols (I.e. CL-ML) are required.

CLASSIFICATIONS BASED ON PERCENTAGE OF FINES

Less than 5%, Pass No. 200 (75mm)sieve)
More than 12% Pass N. 200 (75 mm) sieve
5%-12% Pass No. 200 (75 mm) sieve

GW, GP, SW, SP
GM, GC, SM, SC
Borderline Classification
requiring use of dual symbols

CONSISTENCY

CLAYS AND PLASTIC SILTS	STRENGTH TON/SQ. FT ++	BLOWS/ FOOT +
VERY SOFT	0 - 1/4	0 - 2
SOFT	1/4 - 1/2	2 - 4
FIRM	1/2 - 1	4 - 8
STIFF	1 - 2	8 - 16
VERY STIFF	2 - 4	16 - 32
HARD	Over 4	Over 32

RELATIVE DENSITY

SANDS, GRAVELS AND NON-PLASTIC SILTS	BLOWS/ FOOT +
VERY LOOSE	0 - 4
LOOSE	4 - 10
MEDIUM DENSE	10 - 30
DENSE	30 - 50
VERY DENSE	Over 50

+ Number of blows of a 140-pound hammer falling 30-inches to drive a 2-inch O.D. (1-3/8-inch I.D.) split spoon (ASTM D1586).

++ Unconfined compressive strength in tons/sq.ft. as determined by laboratory testing or approximated by the standard penetration test (ASTM D1586), pocket penetrometer, torvane, or visual observation.

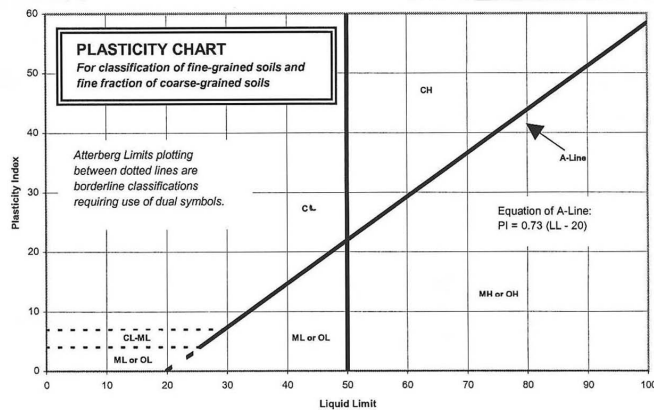

Drilling Notes:

1. Sampling and blow counts
 - a. California Modified – number of blows per foot of a 140 pound hammer falling 30 inches
 - b. Standard Penetration Test – number of blows per 12 inches of a 140 pound hammer falling 30 inches

Types of Samples:
X – Sample
SPT - Standard Penetration
CA - California Modified
N - Nuclear Gauge
PO – Pocket Penetrometer (tons/sq.ft.)



220 High Street, San Luis Obispo, CA 93401
 Phone: 805-543-8539
 1021 Tama Lane, Ste 105, Santa Maria, CA 93455
 Phone: 805-614-6333
 201 S. Milpas St, Ste 103, Santa Barbara, CA 93103
 Phone: 805-966-2200

BORING LOG

BORING NO. B-1
JOB NO. SL12170-1

PROJECT INFORMATION		DRILLING INFORMATION	
PROJECT:	Cambria Skatepark	DRILL RIG:	Mobile B-24
DRILLING LOCATION:	See Figure, Field Investigation	HOLE DIAMETER:	6 Inches
DATE DRILLED:	July 14, 2021	SAMPLING METHOD:	SPT
LOGGED BY:	G. Vine	APPROX. ELEVATION:	Not Recorded

Depth of Groundwater: **Not Encountered** Boring Terminated: **4 Feet** Page 1 of 1

DEPTH	LITHOLOGY	USCS	SOIL DESCRIPTION	SAMPLE ID	SAMPLERS TYPE	N (BLOWS / FT)	(N) 60	MOISTURE CONTENT (%)	FINES CONTENT (%)	PLASTICITY INDEX (PI)	EXPANSION INDEX (EI)	OPTIMUM WATER CONTENT (%)	MAXIMUM DRY DENSITY (pcf)	COHESION, C (psf)	FRICION ANGLE, (degrees)
-------	-----------	------	------------------	-----------	---------------	----------------	--------	----------------------	-------------------	-----------------------	----------------------	---------------------------	---------------------------	-------------------	--------------------------

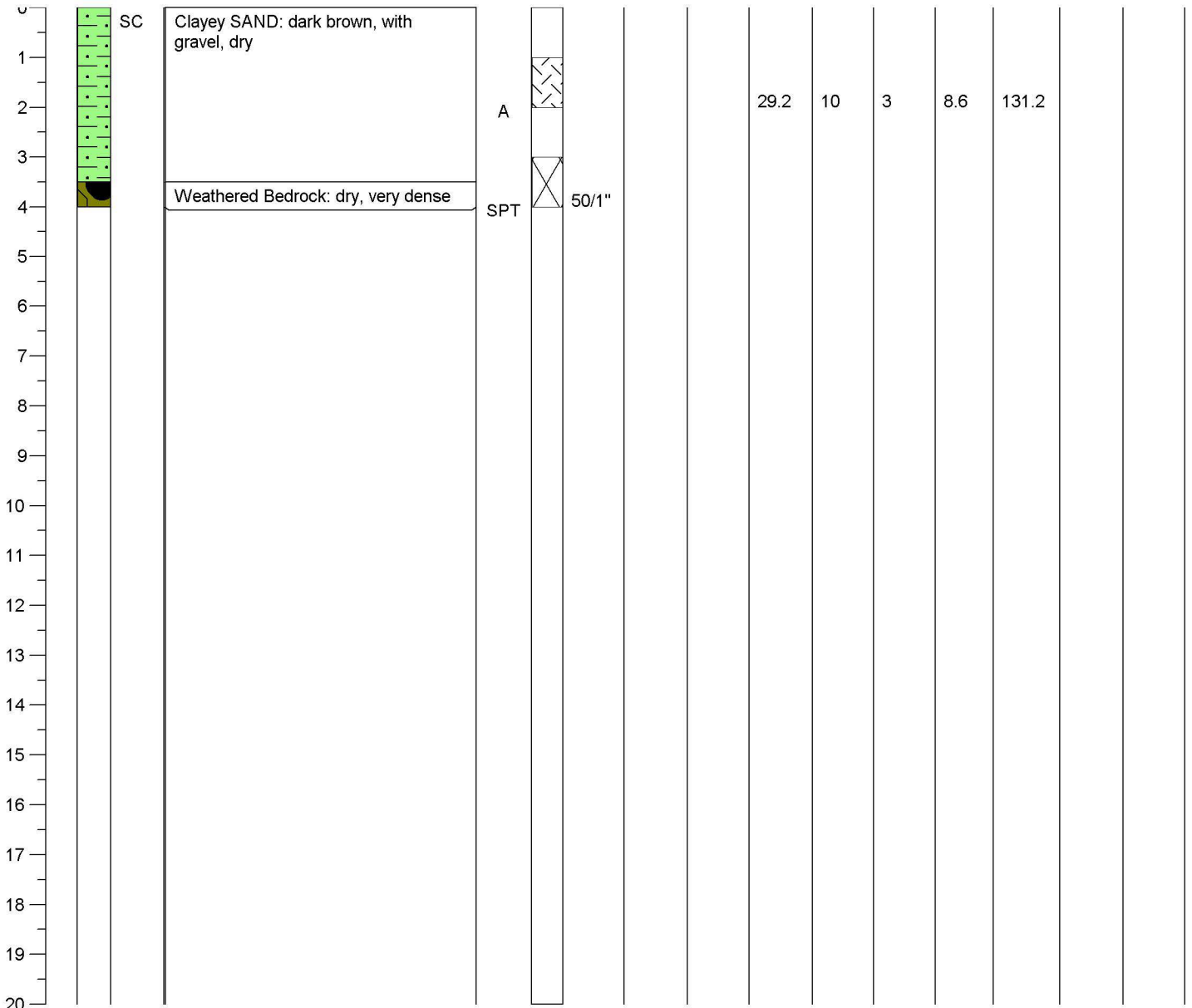



220 High Street, San Luis Obispo, CA 93401
 Phone: 805-543-8539
 1021 Tama Lane, Ste 105, Santa Maria, CA 93455
 Phone: 805-614-6333
 201 S. Milpas St, Ste 103, Santa Barbara, CA 93103
 Phone: 805-966-2200

BORING LOG

BORING NO. B-2
JOB NO. SL12170-1

PROJECT INFORMATION		DRILLING INFORMATION	
PROJECT:	Cambria Skatepark	DRILL RIG:	Mobile B-24
DRILLING LOCATION:	See Figure, Field Investigation	HOLE DIAMETER:	6 Inches
DATE DRILLED:	July 14, 2021	SAMPLING METHOD:	SPT
LOGGED BY:	G. Vine	APPROX. ELEVATION:	Not Recorded

Depth of Groundwater: **Not Encountered** Boring Terminated: **4 Feet** Page 1 of 1

DEPTH	LITHOLOGY	USCS	SOIL DESCRIPTION	SAMPLE ID	SAMPLERS TYPE	N (BLOWS / FT)	(N) 60	MOISTURE CONTENT (%)	FINES CONTENT (%)	PLASTICITY INDEX (PI)	EXPANSION INDEX (EI)	OPTIMUM WATER CONTENT (%)	MAXIMUM DRY DENSITY (pcf)	COHESION, C (psf)	FRICION ANGLE, (degrees)
-------	-----------	------	------------------	-----------	---------------	----------------	--------	----------------------	-------------------	-----------------------	----------------------	---------------------------	---------------------------	-------------------	--------------------------

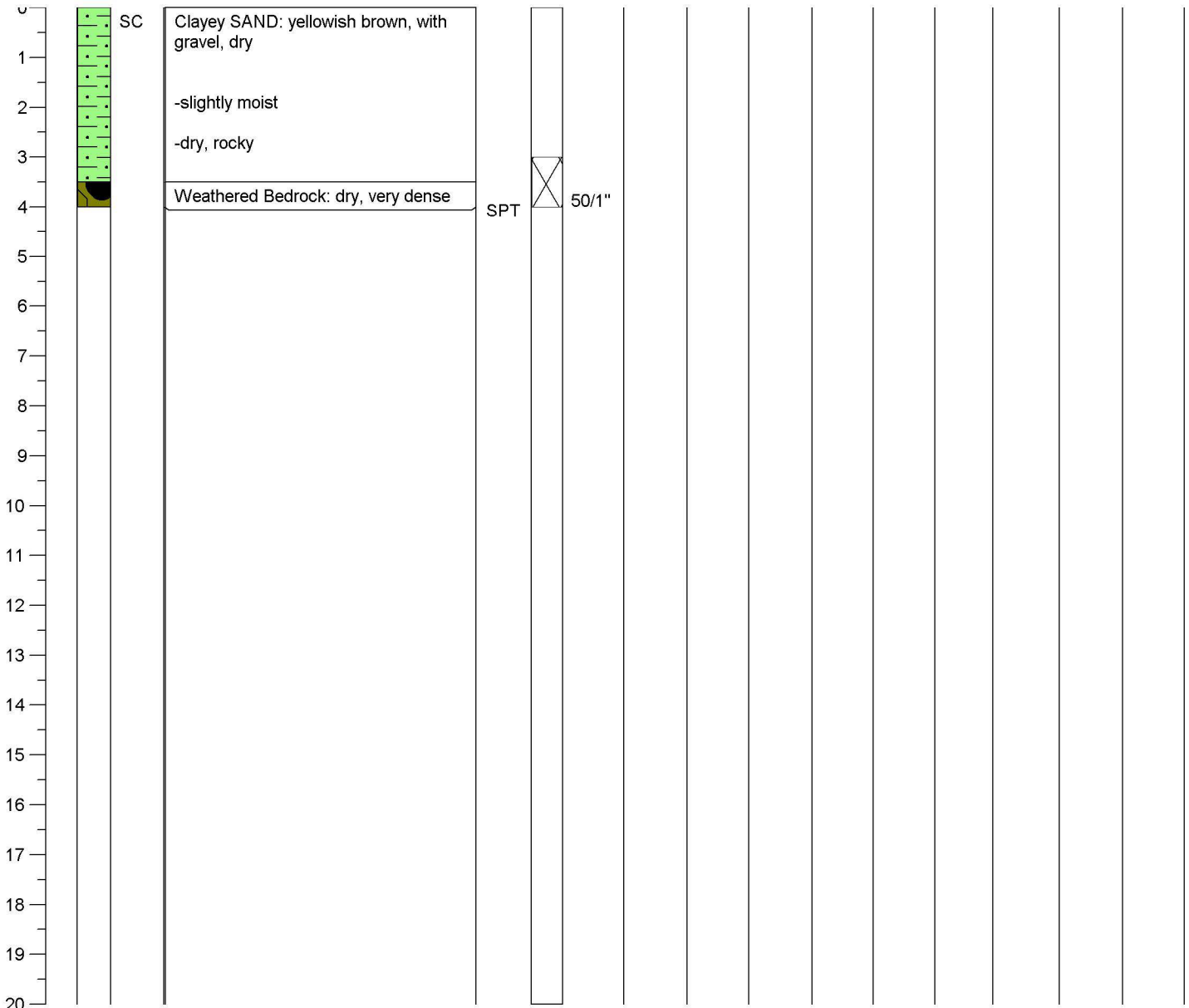

APPENDIX B

Laboratory Testing

Soil Test Reports

LABORATORY TESTING

This appendix includes a discussion of the test procedures and the laboratory test results performed as part of this investigation. The purpose of the laboratory testing is to assess the engineering properties of the soil materials at the Site. The laboratory tests are performed using the currently accepted test methods, when applicable, of the American Society for Testing and Materials (ASTM).

Undisturbed and disturbed bulk samples used in the laboratory tests are obtained from various locations during the course of the field exploration, as discussed in **Appendix A** of this report. Each sample is identified by sample letter and depth. The Unified Soils Classification System is used to classify soils according to their engineering properties. The various laboratory tests performed are described below:

Expansion Index of Soils (ASTM D4829) is conducted in accordance with the ASTM test method and the California Building Code Standard, and are performed on representative bulk and undisturbed soil samples. The purpose of this test is to evaluate expansion potential of the site soils due to fluctuations in moisture content. The sample specimens are placed in a consolidometer, surcharged under a 144-psf vertical confining pressure, and then inundated with water. The amount of expansion is recorded over a 24-hour period with a dial indicator. The expansion index is calculated by determining the difference between final and initial height of the specimen divided by the initial height.

Laboratory Compaction Characteristics of Soil Using Modified Effort (ASTM D1557) is performed to determine the relationship between the moisture content and density of soils and soil-aggregate mixtures when compacted in a standard size mold with a 10-lbf hammer from a height of 18 inches. The test is performed on a representative bulk sample of bearing soil near the estimated footing depth. The procedure is repeated on the same soil sample at various moisture contents sufficient to establish a relationship between the maximum dry unit weight and the optimum water content for the soil. The data, when plotted, represents a curvilinear relationship known as the moisture density relations curve. The values of optimum water content and modified maximum dry unit weight can be determined from the plotted curve.

Liquid Limit, Plastic Limit, and Plasticity Index of Soils (ASTM D4318) are the water contents at certain limiting or critical stages in cohesive soil behavior. The liquid limit (LL or W_L) is the lower limit of viscous flow, the plastic limit (PL or W_P) is the lower limit of the plastic stage of clay and plastic index (PI or I_P) is a range of water content where the soil is plastic. The Atterberg Limits are performed on samples that have been screened to remove any material retained on a No. 40 sieve. The liquid limit is determined by performing trials in which a portion of the sample is spread in a brass cup, divided in two by a grooving tool, and then allowed to flow together from the shocks caused by repeatedly dropping the cup in a standard mechanical device. To determine the Plastic Limit a small portion of plastic soil is alternately pressed together and rolled into a 1/8-inch diameter thread. This process is continued until the water content of the sample is reduced to a point at which the thread crumbles and can no longer be pressed together and re-rolled. The water content of the soil at this point is reported as the plastic limit. The plasticity index is calculated as the difference between the liquid limit and the plastic limit.

Particle Size Analysis of Soils (ASTM D422) is used to determine the particle-size distribution of fine and coarse aggregates. In the test method the sample is separated through a series of sieves of progressively smaller openings for determination of particle size distribution. The total percentage passing each sieve is reported and used to determine the distribution of fine and coarse aggregates in the sample.

Project: Cambria Skatepark
 Client: Spohn Ranch Skateparks
 Project #: SL12170-1

Date: 8/3/21
 Checked by: AE

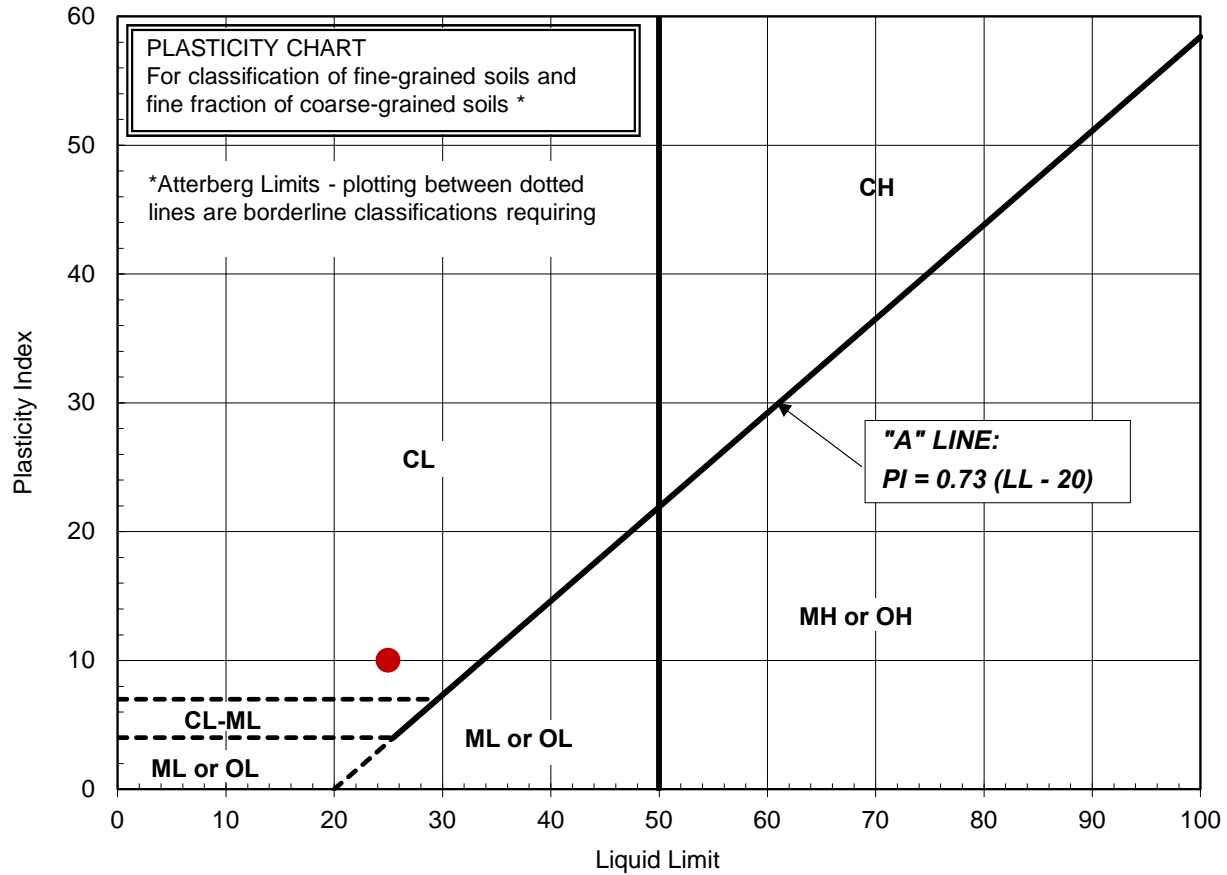

LEGEND			CLASSIFICATION	TEST RESULTS		
symbol	location	depth		Liquid Limit (LL)	Plastic Limit (PL)	Plasticity Index (PI)
●	B-1	0-3'	Dark Brown Clayey SAND	25	15	10

Remarks:

Testing was performed in accordance with ASTM D4318

NP - material tested is nonplastic (liquid or plastic limit tests could not be performed)

Project: Cambria Skatepark

Client: Spohn Ranch Skateparks

Date: 8/3/2021

Project #: SL12170-1

Checked By: AE

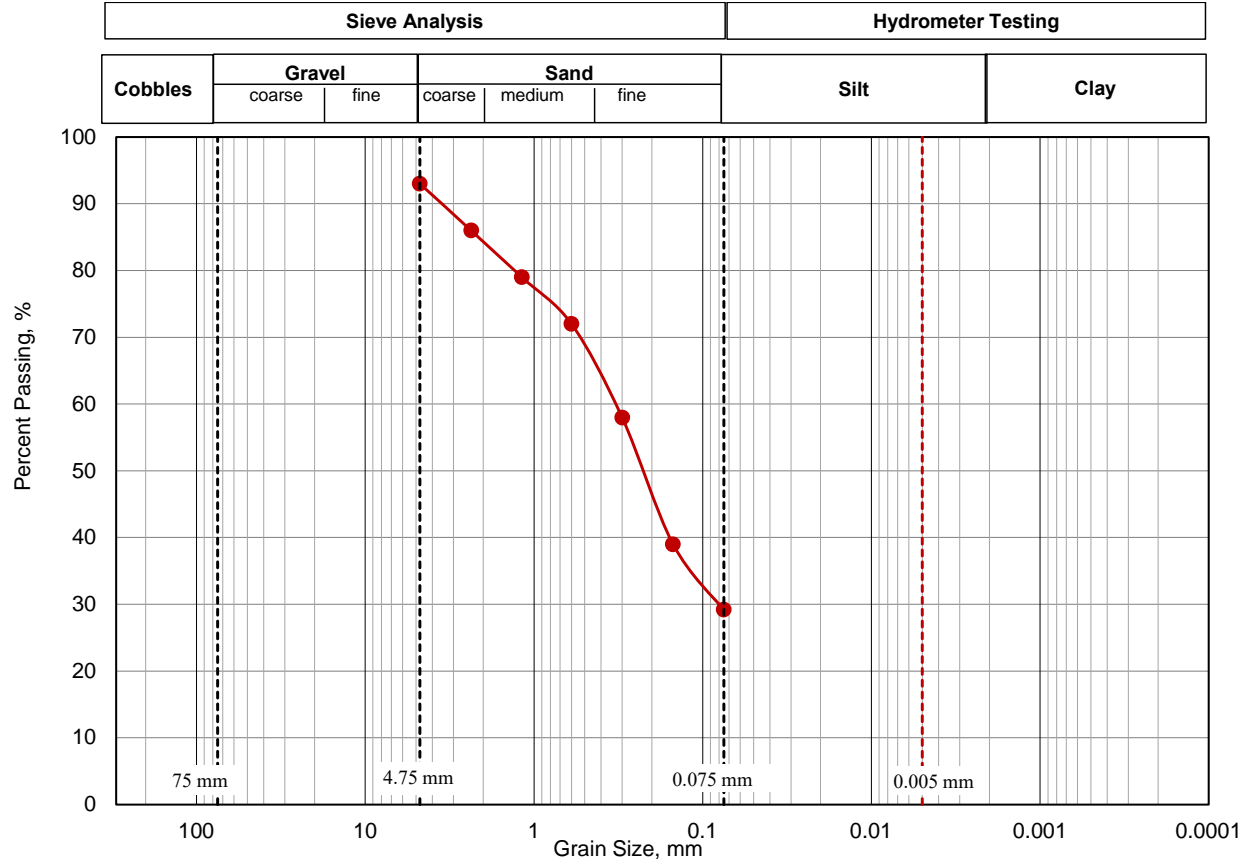

LEGEND

symbol	location	depth
●	B-1	0-3'

SAMPLE DESCRIPTION

Dark Brown Clayey SAND

PLASTICITY (FINER FRACTION)

Liquid Limit (LL)	Plastic Limit (PL)	Plasticity Index (PI)	Expansion Index (EI)
25	15	10	3

LEGEND

symbol	location	depth
●	B-1	0-3'

PARTICLE SIZE ANALYSIS SUMMARY

symbol	location	depth	D ₁₀₀	D ₆₀	D ₃₀	D ₁₀	C _u	C _c	% Gravel	% Sand	% Passing No. 200	% Silt	% Clay
●	B-1	0-3'	#N/A	#####	0.081	NA	NA	NA	7.0	63.8	29.2	NM	NA

Remarks: Testing was performed in accordance with ASTM D422 and D4318 (where applicable)

NP - non-plastic
NA - not available (could not be calculated from data)

D₁₀₀ - grain size diameter corresponding to 100% passing (mm)
D₆₀ - grain size diameter corresponding to 60% passing (mm)
D₃₀ - grain size diameter corresponding to 30% passing (mm)
D₁₀ - grain size diameter corresponding to 10% passing (mm)

C_c - coefficient of curvature: $C_c = (D_{30})^2 / (D_{60} * D_{10})$
C_u - coefficient of uniformity: $C_u = D_{60} / D_{10}$

Project: Cambria Skatepark	Date Tested: July 27, 2021
Client: Spohn Ranch Skateparks	Project #: SL12170-1
Sample: A Depth: 0.0 to 3.0 Feet	Lab #: 11368
Source: B-1	Sample Date: July 14, 2021
Material: Dark Brown Clayey SAND	Sampled By: DW

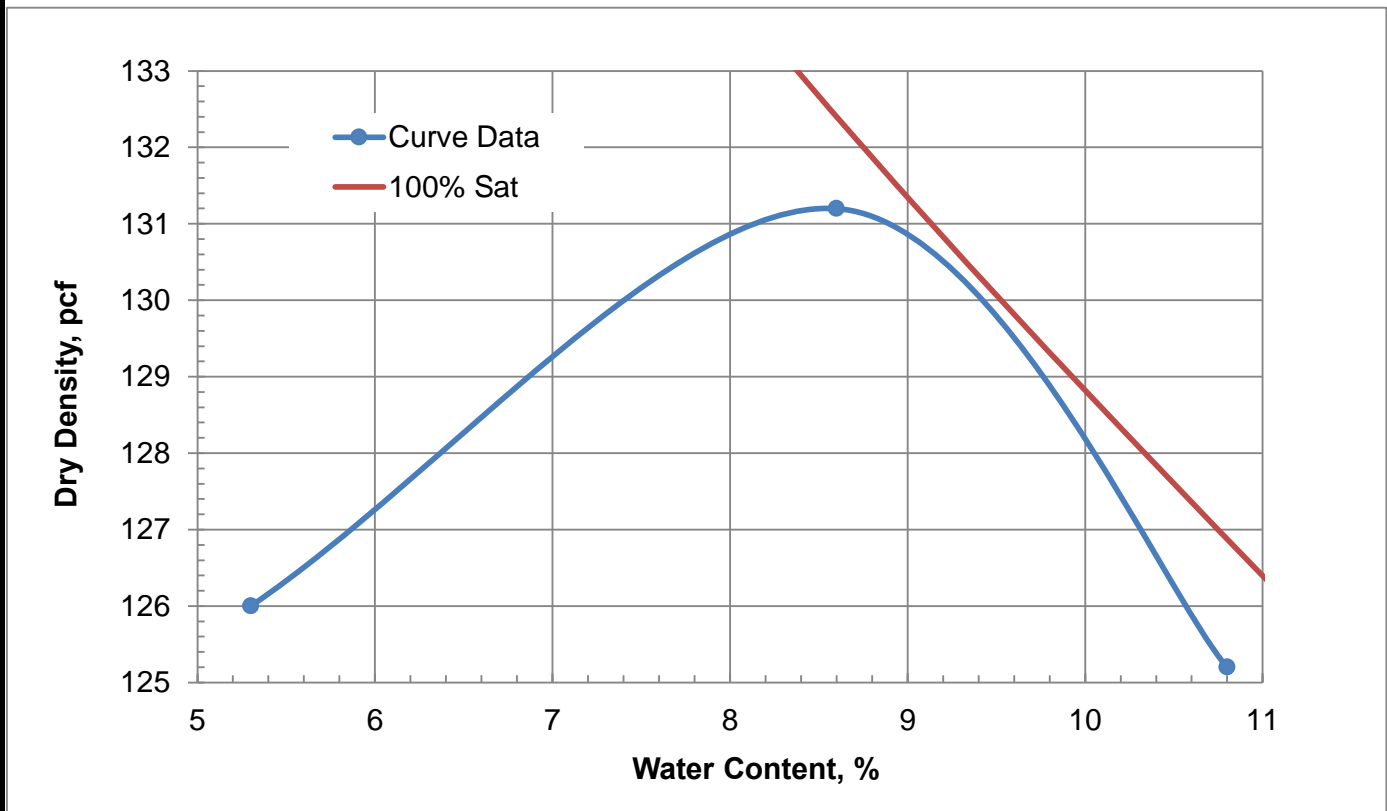

ASTM Test Designation: D 698 D 1557
 Method (sieve size): A (#4) B (3/8") C (3/4")
 % Passing, Pf: _____ % Retained, Pc: _____ Estimated Measured
 Type of Rammer: Mechanical Manual
 Preparation Method Moist Dry
 100% Saturation Curve-Estimated Gs: **2.6**

Laboratory Test Results

Trial #	1	2	3	4
Water Content, %	5.3	8.6	10.8	
Dry Density, pcf	126.0	131.2	125.2	

MAXIMUM DRY DENSITY, pcf:	131.2	OPTIMUM MOISTURE, %:	8.6
----------------------------------	--------------	-----------------------------	------------

Report By: Aaron Eichman

APPENDIX C

Seismic Hazard Analysis

Design Map Summary (SEAOC, 2019)

SEISMIC HAZARD ANALYSIS

According to section 1613 of the 2019 CBC (CBSC, 2019), all structures and portions of structures should be designed to resist the effects of seismic loadings caused by earthquake ground motions in accordance with the *ASCE 7: Minimum Design Loads for Buildings and Other Structures*, hereafter referred to as ASCE7-16 (ASCE, 2016). Estimating the design ground motions at the Site depends on many factors including the distance from the Site to known active faults; the expected magnitude and rate of recurrence of seismic events produced on such faults; the source-to-site ground motion attenuation characteristics; and the Site soil profile characteristics. As per section 1613.2.2 of the 2019 CBC, the Site soil profile classification is determined by the average soil properties in the upper 100 feet of the Site profile and can be determined based on the criteria provided in Table 20.3-1 of ASCE7-16.

ASCE7-16 provides recommendations for estimating site-specific ground motion parameters for seismic design considering a Risk-targeted Maximum Considered Earthquake (MCE_R) in order to determine *design spectral response accelerations* and a Maximum Considered Earthquake Geometric Mean (MCE_G) in order to determine probabilistic geometric mean *peak ground accelerations*.

Spectral accelerations from the MCE_R are based on a 5% damped acceleration response spectrum and a 1% probability of exceedance in 50 years. *Maximum* short period (S_s) and 1-second period (S_1) spectral accelerations are interpolated from the MCE_R -based ground motion parameter maps for bedrock, provided in ASCE7-16. These spectral accelerations are then multiplied by site-specific coefficients (F_a , F_v), based on the Site soil profile classification and the maximum spectral accelerations determined for bedrock, to yield the *maximum* short period (S_{MS}) and 1-second period (S_{M1}) spectral response accelerations at the Site. According to section 11 of ASCE7-16 and section 1613 of the 2019 CBC, buildings and structures should be specifically proportioned to resist *design* earthquake ground motions. Section 1613.2.4 of the 2019 CBC indicates the site-specific *design* spectral response accelerations for short (S_{DS}) and 1-second (S_{D1}) periods can be taken as two-thirds of *maximum* ($S_{DS} = 2/3 * S_{MS}$ and $S_{D1} = 2/3 * S_{M1}$).

Per ASCE7-16, Section 21.5, the probabilistic maximum mean peak ground acceleration (PGA) corresponding to the MCE_G can be computed assuming a 2% probability of exceedance in 50 years (2475-year return period) and is initially determined from mapped ground accelerations for bedrock conditions. The site-specific peak ground acceleration (PGA_M) is then determined by multiplying the PGA by the site-specific coefficient F_h (where F_h is a function of Site Class and PGA).

Spectral response accelerations and peak ground accelerations, provided in this report were obtained using the computer-based Seismic Design Maps tool available from the Structural Engineers Association of California (SEAOC, 2019). This program utilizes the methods developed in ASCE 7-16 in conjunction with user-inputted Site location to calculate seismic design parameters and response spectra (both for period and displacement) for soil profile Site Classes A through E.



Cambria Skatepark

Latitude, Longitude: 35.565308, -121.096806



Date	8/17/2021, 9:42:39 AM
Design Code Reference Document	ASCE7-16
Risk Category	II
Site Class	C - Very Dense Soil and Soft Rock

Type	Value	Description
S_S	1.226	MCE_R ground motion. (for 0.2 second period)
S_1	0.442	MCE_R ground motion. (for 1.0s period)
S_{MS}	1.471	Site-modified spectral acceleration value
S_{M1}	0.663	Site-modified spectral acceleration value
S_{DS}	0.981	Numeric seismic design value at 0.2 second SA
S_{D1}	0.442	Numeric seismic design value at 1.0 second SA

Type	Value	Description
SDC	D	Seismic design category
F_a	1.2	Site amplification factor at 0.2 second
F_v	1.5	Site amplification factor at 1.0 second
PGA	0.553	MCE_G peak ground acceleration
F_{PGA}	1.2	Site amplification factor at PGA
PGA_M	0.664	Site modified peak ground acceleration
T_L	8	Long-period transition period in seconds
$SsRT$	1.226	Probabilistic risk-targeted ground motion. (0.2 second)
$SsUH$	1.372	Factored uniform-hazard (2% probability of exceedance in 50 years) spectral acceleration
SsD	2.319	Factored deterministic acceleration value. (0.2 second)
$S1RT$	0.442	Probabilistic risk-targeted ground motion. (1.0 second)
$S1UH$	0.484	Factored uniform-hazard (2% probability of exceedance in 50 years) spectral acceleration.
$S1D$	0.883	Factored deterministic acceleration value. (1.0 second)
$PGAd$	0.969	Factored deterministic acceleration value. (Peak Ground Acceleration)
C_{RS}	0.894	Mapped value of the risk coefficient at short periods
C_{R1}	0.913	Mapped value of the risk coefficient at a period of 1 s

DISCLAIMER

While the information presented on this website is believed to be correct, SEAOC / OSHPD and its sponsors and contributors assume no responsibility or liability for its accuracy. The material presented in this web application should not be used or relied upon for any specific application without competent examination and verification of its accuracy, suitability and applicability by engineers or other licensed professionals. SEAOC / OSHPD do not intend that the use of this information replace the sound judgment of such competent professionals, having experience and knowledge in the field of practice, nor to substitute for the standard of care required of such professionals in interpreting and applying the results of the seismic data provided by this website. Users of the information from this website assume all liability arising from such use. Use of the output of this website does not imply approval by the governing building code bodies responsible for building code approval and interpretation for the building site described by latitude/longitude location in the search results of this website.

APPENDIX D

Preliminary Grading Specifications

PRELIMINARY GRADING SPECIFICATIONS

A. General

1. These preliminary specifications have been prepared for the subject site; GeoSolutions, Inc. should be consulted prior to the commencement of site work associated with site development to ensure compliance with these specifications.
2. GeoSolutions, Inc. should be notified at least 72 hours prior to site clearing or grading operations on the property in order to observe the stripping of surface materials and to coordinate the work with the grading contractor in the field.
3. These grading specifications may be modified and/or superseded by recommendations contained in the text of this report and/or subsequent reports.
4. If disputes arise out of the interpretation of these grading specifications, the Soils Engineer shall provide the governing interpretation.

B. Obligation of Parties

1. The Soils Engineer should provide observation and testing services and should make evaluations to advise the client on geotechnical matters. The Soils Engineer should report the findings and recommendations to the client or the authorized representative.
2. The client should be chiefly responsible for all aspects of the project. The client or authorized representative has the responsibility of reviewing the findings and recommendations of the Soils Engineer. During grading the client or the authorized representative should remain on-site or should remain reasonably accessible to all concerned parties in order to make decisions necessary to maintain the flow of the project.
3. The contractor is responsible for the safety of the project and satisfactory completion of all grading and other operations on construction projects, including, but not limited to, earthwork in accordance with project plans, specifications, and controlling agency requirements.

C. Site Preparation

1. The client, prior to any site preparation or grading, should arrange and attend a meeting which includes the grading contractor, the design Structural Engineer, the Soils Engineer, representatives of the local building department, as well as any other concerned parties. All parties should be given at least 72 hours' notice.
2. All surface and sub-surface deleterious materials should be removed from the proposed building and pavement areas and disposed of off-site or as approved by the Soils Engineer. This includes, but is not limited to, any debris, organic materials, construction spoils, buried utility line, septic systems, building materials, and any other surface and subsurface structures within the proposed building areas. Trees designated for removal on the construction plans should be removed and their primary root systems grubbed under the observations of a representative of GeoSolutions, Inc. Voids left from site clearing should be cleaned and backfilled as recommended for structural fill.
3. Once the Site has been cleared, the exposed ground surface should be stripped to remove surface vegetation and organic soil. A representative of GeoSolutions, Inc. should determine the required depth of stripping at the time of work being completed. Strippings may either be disposed of off-site or stockpiled for future use in landscape areas, if approved by the landscape architect.

D. Site Protection

1. Protection of the Site during the period of grading and construction should be the responsibility of the contractor.
2. The contractor should be responsible for the stability of all temporary excavations.
3. During periods of rainfall, plastic sheeting should be kept reasonably accessible to prevent unprotected slopes from becoming saturated. Where necessary during periods of rainfall, the contractor should install check-dams, de-silting basins, sand bags, or other devices or methods necessary to control erosion and provide safe conditions.

E. Excavations

1. Materials that are unsuitable should be excavated under the observation and recommendations of the Soils Engineer. Unsuitable materials include, but may not be limited to: 1) dry, loose, soft, wet, organic, or compressible natural soils; 2) fractured, weathered, or soft bedrock; 3) non-engineered fill; 4) other deleterious materials; and 5) materials identified by the Soils Engineer or Engineering Geologist.
2. Unless otherwise recommended by the Soils Engineer and approved by the local building official, permanent cut slopes should not be steeper than 2:1 (horizontal to vertical). Final slope configurations should conform to section 1804 of the 2019 California Building Code unless specifically modified by the Soil Engineer/Engineering Geologist.
3. The Soil Engineer/Engineer Geologist should review cut slopes during excavations. The contractor should notify the Soils Engineer/Engineer Geologist prior to beginning slope excavations.

F. Structural Fill

1. Structural fill should not contain rocks larger than 3 inches in greatest dimension, and should have no more than 15 percent larger than 2.5 inches in greatest dimension.
2. Imported fill should be free of organic and other deleterious material and should have very low expansion potential, with a plasticity index of 12 or less. Before delivery to the Site, a sample of the proposed import should be tested in our laboratory to determine its suitability for use as structural fill.

G. Compacted Fill

1. Structural fill using approved import or native should be placed in horizontal layers, each approximately 8 inches in thickness before compaction. On-site inorganic soil or approved imported fill should be conditioned with water to produce a soil water content near optimum moisture and compacted to a minimum relative density of 90 percent based on ASTM D1557-12_{e1}.
2. Fill slopes should not be constructed at gradients greater than 2-to-1 (horizontal to vertical). The contractor should notify the Soils Engineer/Engineer Geologist prior to beginning slope excavations.
3. If fill areas are constructed on slopes greater than 10-to-1 (horizontal to vertical), we recommend that benches be cut every 4 feet as fill is placed. Each bench shall be a minimum of 10 feet wide with a minimum of 2 percent gradient into the slope.

4. If fill areas are constructed on slopes greater than 5-to-1, we recommend that the toe of all areas to receive fill be keyed a minimum of 24 inches into underlying dense material. Key depths are to be observed and approved by a representative of GeoSolutions, Inc. Sub-drains shall be placed in the keyway and benches as required.

H. Drainage

1. During grading, a representative of GeoSolutions, Inc. should evaluate the need for a sub-drain or back-drain system. Areas of observed seepage should be provided with sub-surface drains to release the hydrostatic pressures. Sub-surface drainage facilities may include gravel blankets, rock filled trenches or Multi-Flow systems or equal. The drain system should discharge in a non-erosive manner into an approved drainage area.
2. All final grades should be provided with a positive drainage gradient away from foundations. Final grades should provide for rapid removal of surface water runoff. Ponding of water should not be allowed on building pads or adjacent to foundations. Final grading should be the responsibility of the contractor, general Civil Engineer, or architect.
3. Concentrated surface water runoff within or immediately adjacent to the Site should be conveyed in pipes or in lined channels to discharge areas that are relatively level or that are adequately protected against erosion.
4. Water from roof downspouts should be conveyed in solid pipes that discharge in controlled drainage localities. Surface drainage gradients should be planned to prevent ponding and promote drainage of surface water away from building foundations, edges of pavements and sidewalks. For soil areas we recommend that a minimum of 2 percent gradient be maintained.
5. Attention should be paid by the contractor to erosion protection of soil surfaces adjacent to the edges of roads, curbs and sidewalks, and in other areas where hard edges of structures may cause concentrated flow of surface water runoff. Erosion resistant matting such as Miramat, or other similar products, may be considered for lining drainage channels.
6. Sub-drains should be placed in established drainage courses and potential seepage areas. The location of sub-drains should be determined after a review of the grading plan. The sub-drain outlets should extend into suitable facilities or connect to the proposed storm drain system or existing drainage control facilities. The outlet pipe should consist of a non-perforated pipe the same diameter as the perforated pipe.

I. Maintenance

1. Maintenance of slopes is important to their long-term performance. Precautions that can be taken include planting with appropriate drought-resistant vegetation as recommended by a landscape architect, and not over-irrigating, a primary source of surficial failures.
2. Property owners should be made aware that over-watering of slopes is detrimental to long term stability of slopes.

J. Underground Facilities Construction

1. The attention of contractors, particularly the underground contractors, should be drawn to the State of California Construction Safety Orders for "Excavations, Trenches, Earthwork." Trenches or excavations greater than 5 feet in depth should be shored or sloped back in accordance with OSHA Regulations prior to entry.

2. Bedding is defined as material placed in a trench up to 1 foot above a utility pipe and backfill is all material placed in the trench above the bedding. Unless concrete bedding is required around utility pipes, free-draining sand should be used as bedding. Sand to be used as bedding should be tested in our laboratory to verify its suitability and to measure its compaction characteristics. Sand bedding should be compacted by mechanical means to achieve at least 90 percent relative density based on ASTM D1557-12_{e1}.
3. On-site inorganic soils, or approved import, may be used as utility trench backfill. Proper compaction of trench backfill will be necessary under and adjacent to structural fill, building foundations, concrete slabs, and vehicle pavements. In these areas, backfill should be conditioned with water (or allowed to dry), to produce a soil water content of about 2 to 3 percent above the optimum value and placed in horizontal layers, each not exceeding 8 inches in thickness before compaction. Each layer should be compacted to at least 90 percent relative density based on ASTM D1557-12_{e1}. The top lift of trench backfill under vehicle pavements should be compacted to the requirements given in report under Preparation of Paved Areas for vehicle pavement sub-grades. Trench walls must be kept moist prior to and during backfill placement.

K. Completion of Work

1. After the completion of work, a report should be prepared by the Soils Engineer retained to provide such services. The report should including locations and elevations of field density tests, summaries of field and laboratory tests, other substantiating data, and comments on any changes made during grading and their effect on the recommendations made in the approved Soils Engineering Report.
2. Soils Engineers shall submit a statement that, to the best of their knowledge, the work within their area of responsibilities is in accordance with the approved soils engineering report and applicable provisions within Chapter 18 of the 2019 CBC.