



Cambria Community  
Services District



US Army Corps  
of Engineers

# Cambria Water Supply Alternatives Engineering Technical Memorandum



Cambria, California  
November 27, 2013

**CDM  
Smith**



The information contained in the document titled "Cambria Water Supply Alternatives Engineering Technical Memorandum" dated November 27, 2013 has received appropriate technical review and approval. The conclusions and recommendations presented represent professional judgments and are based upon findings from the investigations and sampling identified in the report and the interpretation of such data based on our experience and background. This acknowledgement is made in lieu of all warranties, either expressed or implied. The activities outlined in this report were performed under the supervision of a California Registered Professional Engineer.

Prepared by:

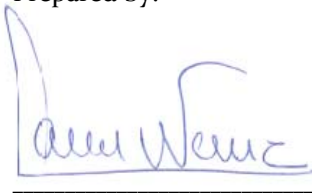

Sava Nedic, PE, PMP, BCEE  
Project Manager



Reviewed and Approved by:



Greg Wettereau, PE  
QA/QC Review

Contributing Authors

Bruce Chalmers  
Sava Nedic  
Mike Smith  
Sandy Sui  
Dan Rodrigo  
Jun Wang

Internal QA/QC Review

Greg Wettereau

Graphics and Production

Kimberly Scheller  
Wendy Coyne

This page intentionally left blank.

# Table of Contents

<b>Executive Summary .....</b>	<b>1</b>
<b>Section 1 Introduction.....</b>	<b>1-1</b>
1.1 Objectives .....	1-1
1.1.1 Technical Inputs for EIR/EIS Processes.....	1-1
1.2 Background and Previous Work.....	1-2
1.2.1 Cambria Community .....	1-2
1.2.2 CCSD Water System Background .....	1-3
1.2.3 Project Driver.....	1-3
1.2.4 Projects before 2008 PEIR .....	1-4
1.2.5 Recommendations of the 2008 PEIR.....	1-5
1.2.6 Seawater Desalination .....	1-6
1.2.7 CCC Consistency Determination and CCSD Decisions.....	1-7
1.3 Overview of Document .....	1-7
<b>Section 2 Cambria Water Supply Tier I Concepts and Options .....</b>	<b>2-1</b>
2.1 Concept Identification Process.....	2-1
2.1.1 Project Team Identified Water Supply Concepts .....	2-1
2.1.2 Additional Water Supply Concepts Identified During Public Scoping Meeting.....	2-2
2.2 Summary of Descriptions and Tier I Screening Results.....	2-2
2.2.1 Water Supply Concept 1 - Shamel Park Option 1.....	2-2
2.2.2 Water Supply Concept 2 - Shamel Park Option 2.....	2-4
2.2.3 Water Supply Concept 3 - Shamel Park Option 3.....	2-6
2.2.4 Water Supply Concept 4 - Shamel Park Option 4.....	2-6
2.2.5 Water Supply Concept 5 - Lampton Park .....	2-8
2.2.6 Water Supply Concept 6 - San Simeon Old Village Seawater Option 1.....	2-8
2.2.7 Water Supply Concept 7 - San Simeon Old Village Seawater Option 2.....	2-11
2.2.8 Water Supply Concept 8 - City of Morro Bay Shared Desalination Facility.....	2-11
2.2.9 Water Supply Concept 9 - Estero Bay Marine Terminal Option 1 .....	2-13
2.2.10 Water Supply Concept 10 - Estero Bay Marine Terminal Option 2 .....	2-15
2.2.11 Water Supply Concept 11 - Estero Bay Marine Terminal Option 3 .....	2-15
2.2.12 Water Supply Concept 12 - San Simeon Creek Road Brackish Water Option 1.....	2-16
2.2.13 Water Supply Concept 13 - San Simeon Creek Road Brackish Water Option 2.....	2-16
2.2.14 Water Supply Concept 14 - San Simeon Creek Road Brackish Water Option 3.....	2-18
2.2.15 Water Supply Concept 15 - Lake Nacimiento Pipeline Option 1 .....	2-18
2.2.16 Water Supply Concept 16 - Lake Nacimiento Pipeline Option 2 .....	2-19
2.2.17 Water Supply Concept 17 - Whale Rock Reservoir with Lake Nacimiento Water Exchange .....	2-21
2.2.18 Water Supply Concept 18 - Whale Rock Reservoir without Lake Nacimiento .....	2-21
2.2.19 Water Supply Concept 19 - Hard Rock Aquifer Storage and Recovery .....	2-24
2.2.20 Water Supply Concept 20 - Wastewater from San Simeon Community Concept.....	2-24
2.2.21 Water Supply Concept 21 - Tropospheric Water Precipitation Concept.....	2-25
2.2.22 Water Supply Concept 22 - Naisetra Offshore Seawater Desalination Concept.....	2-25
2.2.23 Water Supply Concept 23 - Air Force Radar Storm Sewer Outfall Reuse.....	2-26
2.2.24 Water Supply Concept 24 - Small Scale Storage Ponds Concept.....	2-26
2.2.25 Water Supply Concept 25 - Off-Stream Canyon Storage Concept.....	2-26
2.2.26 Water Supply Concept 26 - Water Conservation Concept .....	2-27

2.2.27	Water Supply Concept 27 - Gray Water Concept .....	2-27
2.2.28	Water Supply Concept 28 - Capturing Rainwater Runoffs Concept .....	2-27
2.3	Screening of Tier I concept and options .....	2-27
2.3.1	Screening Results .....	2-28
<b>Section 3</b>	<b>Tier II Water Supply Alternative Concepts .....</b>	<b>3-1</b>
3.1	Concept Development Approach.....	3-1
3.2	Concept Descriptions.....	3-1
3.2.1	Alternative Concept 1 Shamel Park Seawater .....	3-3
3.2.1.1	Alternative Description .....	3-3
3.2.1.2	Flows and Water Mass Balance .....	3-5
3.2.1.3	Water Quality.....	3-5
3.2.1.4	Description of System Facilities .....	3-7
3.2.1.5	Permitting Requirements.....	3-12
3.2.1.6	System Construction Requirements.....	3-12
3.2.1.7	Engineering Cost Estimates.....	3-14
3.2.1.8	Summary of Benefits and Issues .....	3-15
3.2.2	Alternative Concept 2 San Simeon Creek Off-Stream Storage .....	3-17
3.2.2.1	Alternative Description .....	3-17
3.2.2.2	Flows and Water Mass Balance .....	3-20
3.2.2.3	Water Quality.....	3-21
3.2.2.4	Description of System Facilities .....	3-22
3.2.2.5	Permitting Requirements.....	3-29
3.2.2.6	System Construction Requirements.....	3-30
3.2.2.7	Engineering Cost Estimates.....	3-31
3.2.2.8	Summary of Benefits and Issues .....	3-32
3.2.3	Alternative Concept 3 Morro Bay Shared SWRO.....	3-34
3.2.3.1	Alternative Description .....	3-34
3.2.3.2	Flows and Water Mass Balance .....	3-36
3.2.3.3	Water Quality.....	3-36
3.2.3.4	Description of System Facilities .....	3-38
3.2.3.5	Permitting Requirements.....	3-43
3.2.3.6	System Construction Requirements.....	3-43
3.2.3.7	Engineering Cost Estimates.....	3-45
3.2.3.8	Summary of Benefits and Issues .....	3-46
3.2.4	Alternative Concept 4 Estero Bay Marine Terminal.....	3-47
3.2.4.1	Alternative Description .....	3-47
3.2.4.2	Flows and Water Mass Balance .....	3-49
3.2.4.3	Water Quality.....	3-50
3.2.4.4	Description of System Facilities .....	3-51
3.2.4.5	Permitting Requirements.....	3-54
3.2.4.6	System Construction Requirements.....	3-55
3.2.4.7	Engineering Cost Estimates.....	3-56
3.2.4.8	Summary of Benefits and Issues .....	3-57
3.2.5	Alternative Concept 5 - San Simeon Creek Road Brackish Water .....	3-58
3.2.5.1	Alternative Description .....	3-60
3.2.5.2	Flows and Water Mass Balance .....	3-63
3.2.5.3	Water Quality and Reliability .....	3-66
3.2.5.4	Description of System Facilities .....	3-68
3.2.5.5	Permitting Requirements.....	3-80

3.2.5.6	System Construction Requirements.....	3-81
3.2.5.7	Engineering Cost Estimates.....	3-82
3.2.5.8	Summary of Benefits and Issues .....	3-83
3.2.6	Alternative Concept 6 Hard Rock Water Storage and Recovery Alternative.....	3-85
3.2.6.1	Alternative Description .....	3-85
3.2.6.2	Flows and Water Mass Balance .....	3-85
3.2.6.3	Water Quality.....	3-87
3.2.6.4	Description of the System Facilities.....	3-88
3.2.6.5	Permitting Requirements.....	3-91
3.2.6.6	System Construction Requirements.....	3-91
3.2.6.7	Engineering Cost Estimates.....	3-92
3.2.6.8	Summary of Benefits and Issues .....	3-94
3.2.7	Alternative Concept 7 Whale Rock Reservoir .....	3-95
3.2.7.1	Alternative Description .....	3-95
3.2.7.2	Flows and Water Mass Balance .....	3-99
3.2.7.3	Water Quality.....	3-102
3.2.7.4	Description of System Facilities .....	3-103
3.2.7.5	Permitting Requirements.....	3-108
3.2.7.6	System Construction Requirements.....	3-109
3.2.7.7	Engineering Cost Estimates.....	3-110
3.2.7.8	Summary of Benefits and Issues .....	3-112
3.2.8	Alternative Concept 8 San Simeon CSD Recycled Water .....	3-113
3.2.8.1	Alternative Description .....	3-113
3.2.8.2	Flows and Water Mass Balance .....	3-113
3.2.8.3	Water Quality.....	3-116
3.2.8.4	Description of the System Facilities.....	3-116
3.2.8.5	Permitting Requirements.....	3-119
3.2.8.6	System Construction Requirements.....	3-120
3.2.8.7	Engineering Cost Estimates.....	3-121
3.2.8.8	Summary of Benefits and Issues .....	3-122
<b>Section 4</b>	<b>Evaluation of Tier II Alternative Concepts.....</b>	<b>4-1</b>
4.1	Evaluation Process.....	4-1
4.2	Stakeholder Process.....	4-1
4.3	Decision Software and Data Inputs.....	4-2
4.3.1	Decision Software .....	4-2
4.3.2	Data Inputs.....	4-3
4.4	Evaluation Results and Concept Ranking.....	4-6
<b>Section 5</b>	<b>Summary of Study Results and Recommendations.....</b>	<b>5-1</b>
<b>Section 6</b>	<b>References.....</b>	<b>6-1</b>

# List of Figures

Figure 1.2.1-1	Geographical Location.....	1-2
Figure 2.2.1-1	Water Supply Concept 1 Shamel Park Option 1 Facility Layout.....	2-3
Figure 2.2.2-1	Water Supply Concept 2 Shamel Park Option 2 Facility Layout.....	2-5
Figure 2.2.3-1	Water Supply Concepts 3 and 4 Shamel Park Options 3 and 4 Facility Layout.....	2-7
Figure 2.2.5-1	Water Supply Concept 5 Lampton Park Concept Facility Layout.....	2-9
Figure 2.2.6-1	Water Supply Concepts 6 and 7 San Simeon Seawater Village Options 1 and 2 Facility Layout.....	2-10
Figure 2.2.8-1	Water Supply Concept 8 City of Morro Bay Shared SWRO Facility Layout.....	2-12
Figure 2.2.9-1	Water Supply Concepts 9, 10 and 11 Estero Bay Marine Terminal Concept Options 1, 2 and 3 Facility Layout.....	2-14
Figure 2.2.12-1	Water Supply Concepts 12, 13 and 14 San Simeon Creek Road Brackish Water Concept Options 1, 2 and 3 Facility Layout.....	2-17
Figure 2.2.15-1	Water Supply Concepts 15 and 16 Lake Nacimiento Pipeline Options 1 and 2 Facility Layout.....	2-20
Figure 2.2.17-1	Water Supply Concept 17 Whale Rock Reservoir with Lake Nacimiento Water Exchange Facility Layout.....	2-22
Figure 2.2.18-1	Water Supply Concept 18 Whale Rock Reservoir Without Lake Nacimiento Water Exchange Facility Layout.....	2-23
Figure 3.2.1-1	Alternative Concept 1 Shamel Park Seawater Overall System Layout.....	3-4
Figure 3.2.1-2	SWRO Plant Treatment Process Schematic.....	3-10
Figure 3.2.1-3	Shamel Park SWRO Facility Layout.....	3-13
Figure 3.2.2-1	Alternative Concept 2 San Simeon Creek Off-Stream Storage Overall System Layout.....	3-19
Figure 3.2.2-2	Off-Stream Storage Alternative Concept - System Process Flow Diagram.....	3-22
Figure 3.2.2-3	Off-Stream Storage Alternative Concept - Reservoirs and Dams.....	3-25
Figure 3.2.2-4	WTP Process Flow Diagram.....	3-27
Figure 3.2.2-5	WTP Site Plan.....	3-28
Figure 3.2.3-1	Alternative Concept 3 Morro Bay Shared SWRO Overall System Layout.....	3-35
Figure 3.2.3-2	Alternative Concept 3 Seawater Intake SWRO Plant and Pipeline Connection Detail.....	3-41
Figure 3.2.4-1	Alternative Concept 4 Estero Bay Marine Terminal Overall System Layout.....	3-48
Figure 3.2.4-2	Estero Bay Marine Terminal Seawater Intake and SWRO Plant site.....	3-49
Figure 3.2.5-A1	Alternative Concept 5 San Simeon Creek Road Brackish Water Dry Weather Season Water Flow Balance.....	3-60
Figure 3.2.5-1	Alternative Concept 5 Overall System Layout San Simeon Creek Road Brackish Water.....	3-61
Figure 3.2.5-2	Alternative Concepts San Simeon Creek Road Brackish Water San Simeon Creek Basin Cross Section.....	3-64
Figure 3.2.5-3	San Simeon Creek Road Brackish Water Alternative Concept Process Flow Diagram.....	3-68
Figure 3.2.5-4	Typical Extraction Well Section Figure 3.2.5-5 Wellhead of Typical Extraction Well.....	3-75
Figure 3.2.5-6	AWTP Site Layout.....	3-77
Figure 3.2.5-7	Wellhead of Typical Injection Well.....	3-79
Figure 3.2.6-1	Alternative Concept Hard Rock Aquifer Storage and Recovery Overall System Layout.....	3-86



Figure 3.2.7-1	Alternative Concept Whale Rock Reservoir Overall System Layout .....	3-96
Figure 3.2.7-2	Cambria Water Storage Reservoir and Pump Station .....	3-97
Figure 3.2.7-3	Alternative Site Location for Cambria Pump Station and WTP .....	3-98
Figure 3.2.7-4	Cambria Water Treatment Plant at Proposed Location in Cayucos.....	3-99
Figure 3.2.7-5	Whale Rock Reservoir System Process Flow Diagram .....	3-103
Figure 3.2.7-6	Cambria WTP Process Flow Diagram.....	3-107
Figure 3.2.8-1	Water Supply Concept San Simeon CSD Recycled Water Overall System Layout .....	3-114
Figure 3.2.8-2	CCSD WWTP Process Schematic.....	3-118
Figure 4.1.1-1	Tier II Alternative Concept Evaluation Process .....	4-1
Figure 4.3.1-1	Ranking Methodology used by Criterium DecisionPlus Software .....	4-3
Figure 4.3.2-1	Stakeholder Assigned Weights for Evaluation Criteria .....	4-5
Figure 4.4.1-1	Ranking of Alternatives Using All Criteria.....	4-6
Figure 4.4.1-2	Ranking of Alternatives with Five Most Important Criteria Equally Weighted.....	4-7

## List of Tables

Table 2.1.1-1	Initially Identified Cambria Community Water Supply Concepts.....	2-1
Table 2.1.1-2	Cambria Community Water Supply Concepts Identified by Cambria Residents and Comment Letters in Response to EIR/EIS Notice of Preparation.....	2-2
Table 2.3.1-1	Screening Summary of Tier I Water Supply Concepts and Options.....	2-29
Table 3.2.1-1	Flow Rates .....	3-5
Table 3.2.1-2	Assumed Source Water Quality.....	3-6
Table 3.2.1-3	Product Water Quality Goals .....	3-6
Table 3.2.1-4	Design Criteria .....	3-7
Table 3.2.1-5	Conceptual Estimate of Probable Construction Costs.....	3-14
Table 3.2.1-6	Annual O&M Costs.....	3-15
Table 3.2.1-7	Life Cycle Costs .....	3-15
Table 3.2.2-1	Summary of Rainfall and Runoff Data from 1987 through 2004 .....	3-20
Table 3.2.2-2	Design Capacity for the Off-Stream Storage Reservoirs.....	3-21
Table 3.2.2-3	Water Volume and Flows for Conveyance in Off-Stream Storage .....	3-21
Table 3.2.2-4	Basin Water, Reservoir Stored Water and Final Product Water Quality.....	3-22
Table 3.2.2-5	Off-Stream Storage Alternative Concept - Design Criteria.....	3-22
Table 3.2.2-6	Off-Stream Storage Alternative Concept - Dams and Reservoirs.....	3-26
Table 3.2.2-7	Conceptual Estimate of Probable Construction Cost.....	3-31
Table 3.2.2-8	Estimated Annual O&M Costs .....	3-32
Table 3.2.2-9	Estimated Life Cycle Costs.....	3-32
Table 3.2.3-1	Flow Rates .....	3-36
Table 3.2.3-2	Water Quality Data for the Source Water .....	3-37
Table 3.2.3-3	Product Water Quality Goals .....	3-38
Table 3.2.3-4	Design Criteria .....	3-38
Table 3.2.3-5	Conceptual Estimate of Probable Construction Costs.....	3-45
Table 3.2.3-6	Annual O&M Costs.....	3-45
Table 3.2.3-7	Life Cycle Costs .....	3-46
Table 3.2.4-1	Flow Rates .....	3-50
Table 3.2.4-2	Assumed Source Water Quality.....	3-51
Table 3.2.4-3	Product Water Quality Goals .....	3-51
Table 3.2.4-4	Design Criteria .....	3-52

Table 3.2.4-5	Conceptual Estimate of Probable Construction Costs.....	3-56
Table 3.2.4-6	Annual O&M Cost.....	3-57
Table 3.2.4-7	Life Cycle Costs .....	3-57
Table 3.2.5-A1	Dry Weather Season Flow Balance (AF/6 Dry Season Month).....	3-59
Table 3.2.5-1	System Flows and Allocations (Built Out Conditions With 4,650 Service Connections).....	3-65
Table 3.2.5-2	Water Quality .....	3-67
Table 3.2.5-3	Design Criteria - Recharge Capacity 250 AFY .....	3-68
Table 3.2.5-4	Conceptual Estimate of Probable Construction Cost.....	3-82
Table 3.2.5-5	Annual O&M Costs.....	3-83
Table 3.2.5-6	Life Cycle Costs .....	3-83
Table 3.2.6-1	Flows and Water Volumes.....	3-85
Table 3.2.6-2	Product Water Quality Goals and Regulatory Limits.....	3-87
Table 3.2.6-3	Design Criteria .....	3-88
Table 3.2.6-4	Conceptual Estimate of Probable Construction Costs.....	3-93
Table 3.2.6-5	Annual O&M Cost.....	3-93
Table 3.2.6-6	Life Cycle Costs .....	3-93
Table 3.2.7-1	Sources of Raw Water for CCSD's Whale Rock Reservoir Project .....	3-100
Table 3.2.7-2	Summary of Rainfall and Runoff Data from 1987 through 2004 .....	3-101
Table 3.2.7-3	Whale Rock Reservoir's Current Capacity.....	3-101
Table 3.2.7-4	Water Volume and Flows for Conveyance in Whale Rock Reservoir .....	3-102
Table 3.2.7-5	Required Pumping Capacity for Transfer to Whale Rock Reservoir .....	3-102
Table 3.2.7-6	Basin Water, Whale Rock Reservoir and Final Product Water Quality .....	3-103
Table 3.2.7-7	Whale Rock Reservoir Alternative - Design Criteria .....	3-104
Table 3.2.7-8	Conceptual Estimate of Probable Construction Cost.....	3-111
Table 3.2.7-9	Annual O&M Costs.....	3-111
Table 3.2.7-10	Life Cycle Costs .....	3-111
Table 3.2.8-1	Assumed Source Water Quality.....	3-116
Table 3.2.8-2	Product Water Quality Goals .....	3-116
Table 3.2.8-3	Design Criteria .....	3-117
Table 3.2.8-4	Conceptual Estimate of Probable Construction Costs.....	3-121
Table 3.2.8-5	Annual O&M Costs.....	3-121
Table 3.2.8-6	Life Cycle Costs .....	3-122
Table 4.2.1-1	Stakeholder Workshops for Water Supply Concept Alternatives Evaluation .....	4-2
Table 4.3.2-1	Evaluation Criteria and Metrics .....	4-4
Table 4.4.1-1	Comparison of Rankings .....	4-7

## Appendices

Appendix A	Cost Estimating Spreadsheets
Appendix B	Support for In-Stream Flow Study on San Simeon and Santa Rosa Creeks

# Acronyms/Abbreviations

AF	acre foot
AFY	acre foot per year
AOX	Advanced Oxidation
ASR	Aquifer Storage and Recovery
AWTP	advanced water treatment plant
bgs	below ground surface
Board	CCSD Board of Directors
[Ca(HCO <sub>3</sub> ) <sub>2</sub> ]	calcium bicarbonate
Caltrans	California Department of Transportation
CCB	Chlorine Contact Basin
CCC	California Coastal Commission
CCSD	Cambria Community Services District
CCT	Chlorine Contact Tank
CDP	Criterion Decision Plus or Coastal Development Permit
CDPH	California Department of Health
CECs	constituents of emerging concern
cfs	cubic feet per second
CO <sub>2</sub>	carbon dioxide
DAF	dissolved air floatation
DSOD	Division of Safety of Dams
DWR	Department of Water Resources
DYA	Diaz Yourman Associates
EIS/EIR	Environmental Impact Statement/Environmental Impact Report
ERDs	Energy recovery devices
EUAC	Equivalent Uniform Annual cost
ft <sup>2</sup> /day	square feet per day
GAC	granular activated carbon
gfd	gallon per square foot per day (unit to measure flux)
gpd/ft	gallons per day per foot
gpm	gallons per minute

HDD	horizontally directionally drilled
HDPE	high density polyethylene
LE	low energy
MAR	Multi-attribute Rating
MBNMS	Monterey Bay National Marine Sanctuary
MCL	maximum contaminant levels
MF	membrane filtration
MF/UF	membrane micro/ultrafiltration
MGD	million gallons per day
MtBE	Methyl tert-Butyl Ether
Naisetra Concept	Naisetra Offshore Seawater Desalination Concept
NaOCl	sodium hypochlorite
NGVD	National Geodetic Vertical Datum
NEPA	National Environmental Policy Act
O&M	operation and maintenance
Off-Stream Storage	San Simeon Creek Off-Stream Storage
PCH	Pacific Coast Highway
PEIR	Program Environmental Impact Report
PX	Pressure exchange
RO	reverse osmosis
ROW	right-of-way
RWQCB	Regional Water Quality Control Board
SDI	silt density index
SLO	San Luis Obispo
SMCA	State Marine Conservation Area
SRCNP	Santa Rosa Creek Natural Preserve
SWRCB	State Water Resource Control Board
SWRO	seawater reverse osmosis
TDH	Total discharge head
TDS	total dissolved solids
TM	Technical Memorandum
TOC	Total organic carbon

UEAC	uniform equivalent annual cost
USACE	United States Army Corps of Engineers – Los Angeles District
USGS	United States Geological Survey
UV	ultraviolet light
VFD	Variable Frequency Drive
WMP	Water Master Plan
WWTP	wastewater treatment plant

This page intentionally left blank.

# Executive Summary

Based on the current Water Master Plan, the Los Angeles District of the Army Corps of Engineers entered into a partnership agreement with the Cambria Community Services District to prepare design and provide construction assistance for a new seawater desalination facility to produce 602 acre feet of potable water for the Cambria community over six dry months from May 1st through October 31st. The desalination facility would be located next to the existing Cambria Wastewater Treatment Plant and would be supplied with raw seawater by a subterranean seawater intake located in the Santa Rosa Creek paleochannel at the Shamel Beach area.

However to proceed with this project, the National Environmental Policy Act stipulates that a range of water supply alternatives, not only seawater desalination, needs to be evaluated. To comply with this requirement, the partnership agreement with the Army Corps of Engineers was amended to replace the 30 percent design with engineering support to the Environmental Impact Study process.

In addition, to ease permitting and reduce project costs, the Cambria Community Services District Board of Directors decided during the Board meeting held on August 8, 2012, to reduce capacity of the new water supply from 602 acre-feet to 250 acre-feet over the six dry month season.

The engineering support consisted of identification, development and evaluation of multiple water supply concepts, options and alternatives that are capable of providing 250 acre-foot of water supply to supplement the Cambria community water demand during the six month dry season. This Technical Memorandum documents the engineering support efforts, and provides technical input for the Environmental Impact Study process.

## Tier I Concepts and Options

In a global search for sources of Cambria water supply, twenty eight water supply concepts and options were identified by the project team, Cambria community residents and resource agencies. The initially identified water supply concepts and options included:

- Twelve seawater reverse osmosis desalination concepts and options with potential seawater intake at Shamel Park, Lampton Park, San Simeon Old Village, Morro Bay, and Estero Bay were studied. Also, use of an abandoned Air Force Radar Storm and Sewer Outfall was explored as an option to provide seawater intake.
- Four concepts and options including extraction of the blended secondary effluent and deep aquifer brackish water at the existing percolation ponds in the valley of the San Simeon Creek, and diversion, treatment at Cambria Wastewater Treatment Plant and reuse of the wastewater from the San Simeon Community were studied as recycled water concepts and options.
- Six surface water supply options and concepts including source water from Lake Nacimiento, Whale Rock Reservoir (with and without Lake Nacimiento water exchanges) were studied along with San Simeon Creek and Santa Rosa Creek in-stream and off-stream storage options.
- Hard Rock Aquifer with source water from Santa Rosa Creek was studied as an aquifer storage and recovery concept.

- Finally, five emerging technologies or unconventional water supply concepts, including Tropospheric Water Precipitation, Naisetra Off-shore Seawater Reverse Osmosis Desalination, Rainwater Runoff Retainage, Gray Water and Water Conservation, were studied.

The twenty eight Tier I concepts and options were screened for technical feasibility. The screening criteria included:

- Capacity to provide emergency water supply,
- Technical feasibility, and
- Practical implementability.

## Tier II Alternative Water Supply Concepts

The following eight Tier I concepts and options passed Tier I Screening to become Tier II Alternative Water Supply Concepts:

- **Shamel Park Seawater.** The Shamel Park Seawater alternative concept consists of a subterranean seawater intake, a seawater reverse osmosis plant next to the existing Cambria Community Services District Waste Water Treatment Plant, and concentrate return in Paleochannel C located off-shore at Santa Rosa Beach.
- **San Simeon Creek Off-Stream Storage.** The San Simeon Creek Off-stream Storage alternative concept assumes water diversion from San Simeon Creek during wet weather season and storage in three off-stream reservoirs for treatment and use during dry weather season.
- **Morro Bay Shared SWRO.** The Morro Bay Shared seawater reverse osmosis alternative consists of beach wells to provide seawater intake, an upgrade and upsizing of the existing Morro Bay owned seawater reverse osmosis desalination plant, concentrate return in existing Morro Bay Power Plant cooling water outfall, and about an 18 mile long water pipeline to bring the product water to the Cambria community.
- **Estero Bay Marine Terminal.** The Estero Bay Marine Terminal alternative concept consists of an off-shore subterranean seawater intake at Dog Beach, a seawater reverse osmosis plant located at an open lot approximately 1 mile on-shore along Toro Creek Road, concentrate return in the Morro Bay existing Power Plant cooling water outfall, and about a 16 mile long water pipeline to bring the product water to the Cambria community.
- **San Simeon Creek Road Brackish Water.** The San Simeon Creek Road Brackish Water alternative concept assumes extraction of the brackish ground water from the San Simeon Creek Basin in the vicinity of the existing Percolation Ponds, purification of the extracted water by a membrane advanced water treatment plant, and its recharge back into the groundwater basin at the Cambria Community Services District's potable water well field. The recharged groundwater would be extracted for the Cambria water supply by the existing Cambria Community Services District's potable water well pumps. A portion of the purified groundwater would continue to move towards the San Simeon Creek fresh water lagoons downstream of the Percolation Ponds. The treatment plant generated brine/concentrate would be recharged in a seawater wedge close to the ocean shore.



- **Hard Rock Aquifer Storage and Recovery.** The Hard Rock Aquifer Storage and Recovery alternative concept assumes that excess water from Santa Rosa Creek would be pumped, treated to remove iron and manganese, and stored in a confined Hard Rock aquifer during wet season for its future extraction and use to supplement the Cambria water supply during the dry weather season.
- **Whale Rock Reservoir.** The Whale Rock Reservoir alternative concept assumes that the excess surface water from the San Simeon Creek and the Santa Rosa Creek would be pumped and stored in the existing Whale Rock Reservoir during wet weather season for future use during dry weather season. Water conveyance from the two creeks to the Whale Rock Reservoir would be provided through the existing Cambria water distribution piping system and a new pump station and pipeline that would connect the southern tip of the Cambria Community distribution system and Whale Rock Reservoir. The stored water would be pumped from the Whale Rock Reservoir, treated at a new water treatment plant and pumped back to Cambria by the means of the same pipeline to supplement Cambria water supply the during dry season.
- **San Simeon Community Services District Recycled Water.** The San Simeon Community Service District Recycled Water alternative concept includes diversion and pumping wastewater from the San Simeon community to the Cambria Community Service District owned wastewater treatment plant in Cambria for treatment. The waste water treatment plant generated secondary effluent would be filtered and disinfected to produce California Title 22 tertiary effluent for unrestricted non-body-contact irrigation or other industrial use. It is stipulated that 250 acre-feet for irrigation with recycled water would offset 250 acre-feet of potable water demand during six months dry season.

The Tier II alternative concepts were developed in sufficient detail to assess their technical feasibility requirements and to provide an engineering basis for their comparison and ranking. Detailing of each of the Tier II alternative concepts included development of the overall system layouts, water flow balance, source and product water quality assessment, detailed design criteria, and identification of permitting and other construction requirements. Cost estimates included construction cost, Operation & Maintenance cost and life cycle cost. For life cycle costs, 25 year life time and 3.5 percent interest rate were used.

### Evaluation of the Tier II alternative water supply concepts

A transparent and defensible evaluation of the Tier II Alternative Concepts was conducted by using multiple-attribute ranking technique and the Criterium Decision Plus software package. Key project stakeholders including the Cambria Community Services District board of directors, Cambria community residents and resource agencies were engaged in the evaluation process, helping to define evaluation criteria, assigning criteria weights (importance), and reviewing ranking of the alternative.

## Summary of Recommendations

The four highest ranked alternative water supply concepts included the following:

- San Simeon Creek Road Brackish Water,
- Whale Rock Reservoir,

- Shamel Park Seawater, and
- Morro Bay Shared SWRO.

These four concepts are recommended to be included in the follow-up EIS processes.

# Section 1

## Introduction

### 1.1 Objectives

This Engineering Technical Memorandum - Cambria Water Supply Alternatives (TM), was prepared to present a range of water supply alternatives for Cambria Community Services District (CCSD) for the purpose of providing long-term drought protection and seasonally augmenting the community's potable water supply. Through a two-step screening process, four (4) out of the originally identified twenty-eight (28) water supply options have been selected for further evaluation through the formal Environmental Impact Statement/Environmental Impact Report (EIS/EIR) process.

#### 1.1.1 Technical Inputs for EIR/EIS Processes

The current CCSD Water Master Plan (WMP) identified seawater desalination as a critical source of water supply for Cambria during dry seasons. The United States Army Corps of Engineers – Los Angeles District (USACE) entered into a partnership agreement with CCSD to prepare design and provide construction assistance for a new seawater desalination facility. The new facility would have a capacity of 602 acre foot (AF) over six (6) dry months per year, estimated based on the WMP demand projection for a baseline demand with additional 50 percent contingency. The desalination facility would be supplied with raw seawater by a subterranean seawater intake located in the Santa Rosa Creek paleochannel at Shamel Park Beach area. However, the National Environmental Policy Act (NEPA) stipulates that a range of alternative water supply (not only desalination) need to be evaluated. To comply with the requirement twenty-eight (28) water supply concepts and options, inclusive of seawater desalination, were identified before and during a Cambria Water Supply Project Public Scoping Meeting held on March 15, 2012.

A preliminary screening was done for the 28 Tier I water supply options to identify fatal flaws, and eight (8) alternatives were recommended for further development and Tier II evaluation. The preliminary screening criteria and screening matrices were reviewed by the stakeholders and the Cambria community residents in the public Water Supply Engineering Concepts Workshop 1 held on June 14, 2012. Overall facility layouts, sizing, and a planning level cost estimate were presented during the workshop for each of the eight Tier II concepts. An evaluation procedure called Multi-attribute Rating (MAR) was used to compare and rank the Tier II alternatives. The Criterion Decision Plus (CDP) software was applied in the evaluation. The CDP evaluation criteria, as well as criteria importance and weight factors, have been defined during CCSD's public Workshop 2 held on July 19, 2012 with inputs from stakeholders, including the Cambria community residents.

The evaluation criteria and their importance and weight factors, as defined during Workshop 2, were entered into the CDP model to rank the Tier II alternatives. Based on the CDP model results, four (4) top ranked alternatives were recommended for further evaluation through the EIS/EIR process. The recommended alternatives were reviewed during two subsequent CCSD's public workshops including Workshop 3 held on August 9, 2012 and Workshop 4 held on September 18, 2012 when CCSD made its final selection of the alternatives. This TM documents the process and describes the selected alternatives, which are to be further studied and evaluated by the EIS/EIR process. The TM also provides engineering narratives and exhibits to support the EIS/EIR documents.

## 1.2 Background and Previous Work

### 1.2.1 Cambria Community

The unincorporated town of Cambria is located in the State of California, midway between San Francisco and Los Angeles on the Pacific Coast Highway (PCH) in the County of San Luis Obispo (SLO) and about 35 miles northwest of the City of San Luis Obispo. Cambria is bound by the Santa Lucia Mountain Range to the east, the Pacific Ocean to the west, and the Big Sur to the north. The only major north-south transportation is PCH that bisects the community. Highway 46 connects PCH approximately four miles south of Cambria to provide an eastward transportation to inland. The area of Cambria is about four (4) square miles with elevations ranging from sea level to about 200 ft. NGVD (National Geodetic Vertical Datum). Figure 1.2.1-1 shows the location of Cambria.

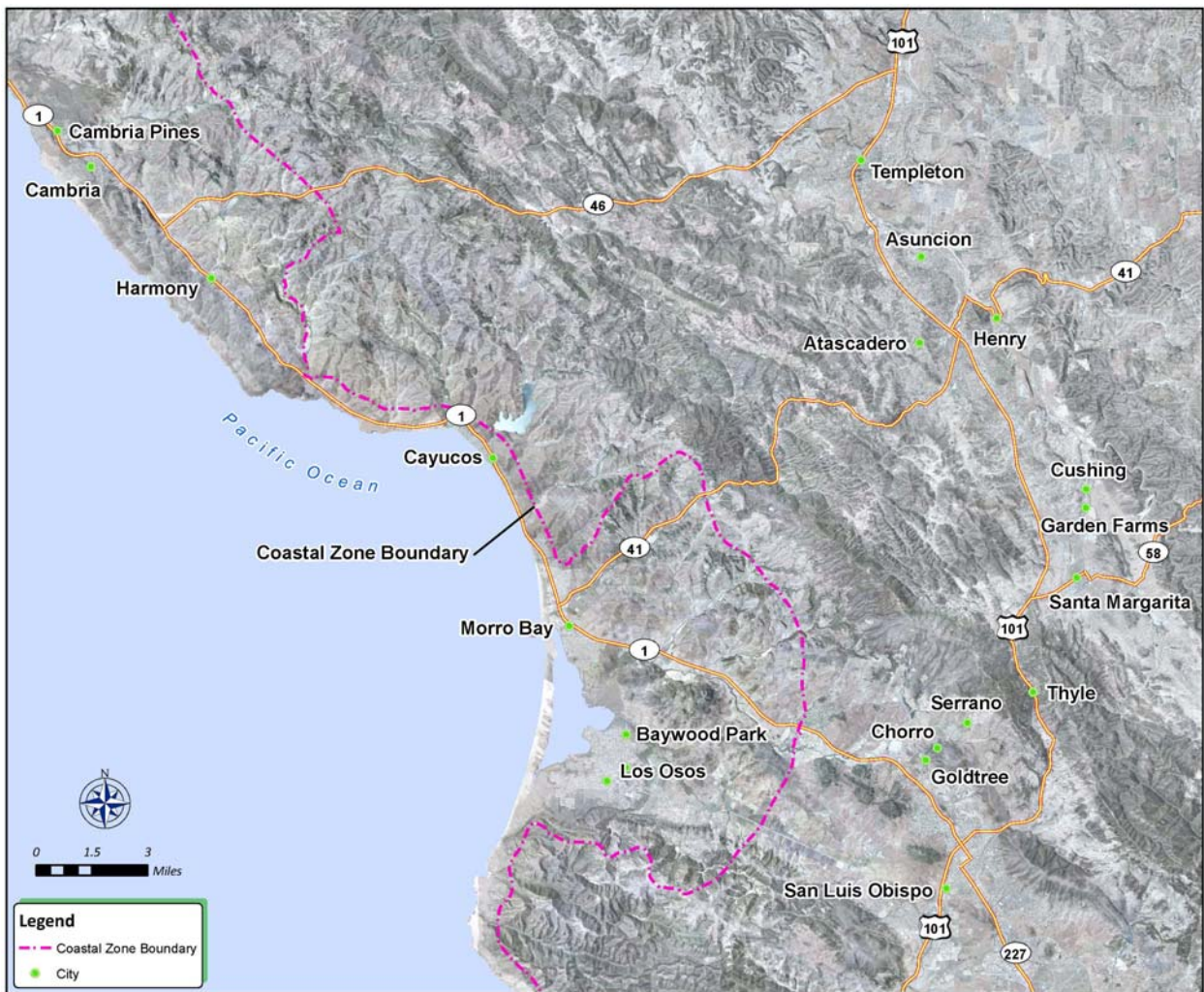

**Figure 1.2.1-1 Geographical Location**

The population of Cambria was 6,032 according to the 2010 census. This census reported that there were 2,762 households in Cambria, with 35 percent of the population between the ages of 45 to 64, and 32 percent of the population 65 years or older. There were 4,062 housing units in Cambria, of which 72 percent were owner-occupied, and 28 percent were occupied by renters. The home vacancy

rate was 32 percent, which indicates that a high percentage of the homes may be second homes or vacation homes.

The primary economic activity of Cambria is tourism. Located on the Pacific Ocean, Cambria has rocky cliffs and beaches. Cambria is home to the Cambria Historical Museum in the historic East Village and California State Historical Landmark. Hearst Castle is located approximately six miles north of Cambria. Besides tourism, agriculture and light industry are also important parts of Cambria's economy.

### 1.2.2 CCSD Water System Background

CCSD was formed in 1977 as a successor to an earlier Cambria County Water District. CCSD provides water supply, wastewater collection and treatment, fire protection, garbage collection, and a limited amount of street lighting and recreation.

CCSD currently serves a year-round population of about 6,032 as well as a large number of tourists and visitors to the community. CCSD service area covers approximately four (4) square miles. There are eight pressure zones within the CCSD's water distribution system, which consists of four groundwater wells, three-distribution system pumping stations, pressure reducing stations, and four water storage reservoirs. The CCSD service area is within the Coastal Zone and therefore within the jurisdiction of the California Coastal Commission (CCC), a state agency with the primary purpose of protecting coastal resources.

The CCSD's potable water is supplied solely from groundwater wells in the San Simeon Creek and Santa Rosa Creek aquifers. The San Simeon Creek and Santa Rosa Creek aquifers are relatively shallow and highly porous, with the groundwater typically depleted during dry season and recharged during the rainy season.

### 1.2.3 Project Driver

The drivers for the Cambria water supply project are to provide reliable and sustained community water supply during dry season and to supplement the current water supply sources.

The CCSD's WMP projected the Cambria community future water demand scenarios under baseline and baseline plus 10 percent, 20 percent, and 50 percent increase contingency water supply conditions that would occur under various occupancy rates. The analyses suggested that a range of 250 to 800 AF of additional long-term water supply needs to be added to the existing water supply system during dry seasons.

The groundwater levels of the San Simeon Creek and Santa Rosa Creek basins are directly influenced by CCSD's pumping, especially during the dry seasons. Because of their relatively shallow and porous nature, the basin's groundwater storage capacity is limited compared with the average annual groundwater pumping. The storage is consequently incapable of sustaining current pumping rates through one or more drought years.

In order to protect the ecosystem sustained by the two groundwater basins, the State Water Resource Control Board (SWRCB) issued appropriations permits to the CCSD, allowing a maximum of 1,230 AF annually from the San Simeon aquifer, while limiting dry season pumping to 370 AF maximum from the time that the creek ceases flow at the Palmer Flats gauging station, to October 31. The Santa Rosa Creek SWRCB appropriations permit limits the Santa Rosa aquifer pumping to 518 AF annually, with a dry season pumping limit of 260 AF from May 1 to October 31. The maximum pumping rates allowed

are 2.5 cubic feet per second (cfs), or 1,120 gallons per minute (gpm) for the San Simeon aquifer; and, 2.67 cfs (1,197 gpm) for the Santa Rosa aquifer. Since the local groundwater aquifers are the only source of water for Cambria, the water supply is very vulnerable to drought. In addition to the SWRCB issued diversion permit limitations, a 1981 Coastal Development Permits (CDP) issued by the CCC to the CCSD limits the total annual diversion from both aquifers to no more than 1,230 AF per year (CDP Permit 428-10, condition 4, May 29, 1981).

In addition to the low water quality in terms of hardness, total dissolved solids (TDS), iron, and manganese concentrations, an MtBE (Methyl tert-butyl ether) plume was discovered in the Santa Rosa well field in 1999. An emergency well SR-4 and associated treatment plant to allow for iron and manganese removal were subsequently installed further upstream of the existing Santa Rosa well field to serve as a back-up and augmentation to the water supply from the San Simeon basin.

To address the concern of Cambria's water availability, in November 2001, the CCSD's Board of Directors declared a Water Code 350 emergency and ceased issuing additional connection permits until an adequate long-term supply project was completed. SLO County reduced Cambria's growth limit to 1 percent in 2000. As of September 20, 2012, the water service connection requests sitting on CCSD's waiting list include 666 single family applications, 13 multi-family applications, and 10 commercial applications. To date, no new connections are being issued and the District remains under a Water Code 350 declaration.

As an interim measure until a new supply project can be completed, the CCSD has developed a demand offset program based on water conservation, which may eventually lead to a limited number of new connections each year. This interim program is still subject to the County's approving a change to the growth rate for Cambria, which is currently set at zero.

Due to the above situations, CCSD is investigating means to further augment and diversify its existing potable supplies to provide drought protection and supplement their current water supply sources.

#### 1.2.4 Projects before 2008 PEIR

A program-level WMP Program Environmental Impact Report (PEIR) was certified by the CCSD Board on August 21, 2008. This PEIR was prepared to review the existing conditions, analyze potential environmental impacts, and identify feasible mitigation measures to reduce potentially significant effects. The proposed project involved an update to the CCSD WMP, which includes a water demand management program, recycled water, seawater desalination and improvements to the potable water distribution system.

Prior to the completion of the PEIR, CCSD had conducted a variety of water supply study projects, which have been incorporated by reference into the PEIR and are listed as follows:

##### 1993 – Desalination Facility Preliminary Site Analysis and Conceptual Study

The study examined various sites and developed a conceptual-level plan for Cambria's seawater desalination project. This study recommended the San Simeon Creek beach over the Santa Rosa Creek beach for seawater intake because it was believed that the San Simeon Creek site would have a more direct hydraulic connection with the ocean and be better situated to connect the desalinated supply downstream from the existing San Simeon well field. The recommended desalination project contains beach well intake and ocean discharge.

### 1994 – Intake/Outfall Structures for Proposed Desalination Facility –Phase I Preliminary Design

During the mid-1990s, preliminary design for a seawater desalination project at San Simeon Creek site had been prepared, but never constructed. Costs and growth were chief concerns that led to this earlier project not being completed.

### 1994 – Cambria Desalination Facility –Final EIR

This document summarizes potential environmental impacts of the project with regard to both project itself and cumulative impacts including potential growth-inducing impacts on water supply. The proposed seawater desalination project would include a seawater desalination plant, seawater intake, transmission facilities and an ocean outfall.

### 2000-2004 - Water Master Planning Update

A phased water master planning effort was also completed from 2001 to 2004, which had produced the following reports:

- Task 2 Report: Baseline Water Supply Analysis
- Task 3 Reports:
  - Potable Water Distribution System Analysis
  - Recycled Water Distribution System Master Plan
- Task 4 Report: Assessment of Long Term Water Supply Alternatives

Potable Water Distribution System Analysis focused on the potable water distribution system and related improvements for firefighting purposes. The Recycled Water Distribution System Master Plan developed a concept for recycled water system and landscape irrigation. The Task 4 Report assessed various long-term supply alternatives. These WMP updates recommended a multifaceted approach that included improvements to the potable distribution system to enhance firefighting, water conservation, non-potable recycled water for irrigation, and further augmenting and drought-proofing the local potable supply using seawater desalination.

### 2004-2006 - Build-out Reduction Plan

In direct response to a 2001 recommendation made by the CCC, a build-out reduction program was developed based on detailed geographical information system mapping and analysis coupled with financial modeling. This work was further reviewed by a local citizens committee, which met for a number of times over a year during its development. The result was a recommended build-out goal of 4,650 existing and future residences. This essentially allowed for an existing water connection wait list of 666 lot owners to proceed at a pace estimated to spread out over 22 years into the future, once the moratorium is lifted.

### 1.2.5 Recommendations of the 2008 PEIR

Based on a qualitative screening level evaluation of the Task 4 WMP Report, the CCSD's long-term water supply strategy is proposed to consist of the following elements:

- Water demand management,
- Recycled water, and
- Seawater desalination.

These recommendations, along with the proposed Potable Water Distribution System Improvements, comprise the WMP components evaluated in the 2008 PEIR. In addition, the 2008 PEIR evaluated a reasonable range of alternative projects, as listed below, for their existing conditions, potential environmental impacts, and feasible mitigation measures to reduce potentially significant impacts.

- “No Project” Alternative,
- “Surface Water From Lake Nacimiento” Alternative,
- “Whale Rock Exchange” Alternative,
- “Hard Rock Drilling” Alternative,
- “Van Gordon Dam and Reservoir” Alternative, and
- “Jack Creek Dam and Reservoir” Alternative.

The evaluations of the 2008 PEIR indicated that there were no unavoidable significant environmental impacts from implementation of the WMP proposed water supply alternatives.

### 1.2.6 Seawater Desalination

In 2010, CCSD entered into a partnership agreement with USACE to implement a seawater desalination project with a subterranean seawater intake located in the Santa Rosa Creek paleochannels. This project would provide an additional water supply of up to 602 AF during the six (6) months yearly dry season. The project would include a subterranean seawater intake, pumping and pipeline facilities to transport the seawater to a seawater reverse osmosis (SWRO) desalination plant, pump and piping facilities to pump the treated water into the distribution system, and a separate pipeline to convey the concentrate return to the ocean via a subterranean concentrate return structure.

In the 2008 PEIR, the capacity of the desalination plant was sized for a 740 gpm permeate flow and operation approximately 183 days per year (600 AF) during the dry season. Three desalination supply capacity alternatives were investigated with permeate flows of 300 gpm, 600 gpm, and 900 gpm.

Seawater desalination can provide a reliable water supply independent of weather conditions and other seasonal impacts, providing high quality water to meet long-term demands. Implementing seawater desalination would reduce reliance on groundwater supplies, and protect the overstressed basins and the habitats in Santa Rosa Creek and San Simeon Creek, as well as riparian habitats during dry periods.



### 1.2.7 CCC Consistency Determination and CCSD Decisions

The potential sites for a seawater intake and concentrate return of the proposed seawater desalination project are within the environmentally sensitive coastline of the Monterey Bay National Marine Sanctuary (MBNMS). Therefore, CCSD evaluated subterranean seawater intakes and concentrate return methods to reduce the potential impacts on the marine environment and simplify the permitting process. The initial geophysical investigation at the Santa Rosa Creek beach discovered the existence of three paleochannels with potential to provide sites for a subterranean seawater intake and RO concentrate return.

The USACE submitted an application to the CCC in 2011 to complete a more detailed geotechnical investigation at the Santa Rosa Creek area, including Shamel Park County Beach and Santa Rosa Creek State Beach, and to seek approval from the CCC on the effort of Coastal Consistency Determination.

During the Coastal Consistency Determination meeting on December 9th, 2011, the CCC voted to deny USACE's request for the site geotechnical investigation. As a result, CCSD made a decision to put on hold the Shamel Beach SWRO water supply alternative from further evaluation.

In order to ease permitting and reduce project costs, during Public Workshop No.2 meeting held on August 8, 2012, the CCSD Board of Directors (Board) decided to reduce the design capacity of the new water supply facility from 600 AF to 250 AF over six (6) dry months per year. The new capacity was based on the CCSD's WMP baseline demand without increased contingency and the assumption that the 2020 water conservation reduction target would be reached.

## 1.3 Overview of Document

This TM is organized in the following six sections:

- Section 1 – Introduction.

This section provides an introduction of the background, drivers, and history of the Cambria long-term water supply efforts to provide a reliable water supply to the community year around and augment their potable water system. This section also provides a brief summary of process and content of this TM.

- Section 2 - Cambria Water Supply Tier I Concepts and Options.

This section provides the description of the twenty eight Tier I water supply options, and a screening process which selected eight options for the Tier II Water Supply Concepts for further development and evaluation.

- Section 3 - Tier II Water Supply Alternative Concepts.

This section provides detailed descriptions of the Tier II water supply alternative concepts, presents planning level engineering results and cost estimates, and summarizes the identified benefit and issues of the selected alternative concepts. The information provided in this section is used as inputs for the CDP evaluation.

- Section 4 - Evaluation of Tier II Alternative Concepts.

This section provides an introduction of CDP method, presents the evaluation process, and ranks the Tier II alternative concepts. The stakeholders' involvement during the whole water supply alternative development and screening process is summarized. The ranking results of the CDP evaluation and board decisions are provided at the end of this section.

- Section 5 - Summary of Study Results and Recommendations.

This Section summarizes the engineering study results for Cambria water supply alternative concepts and recommends four (4) water supply alternatives for the formal EIS/EIR processes.

- Section 6 - References.

## Section 2

# Cambria Water Supply Tier I Concepts and Options

This section describes the process of identifying Tier I water supply concepts for the Cambria community, provides descriptions of the identified options, summarizes the option screening process, and selects eight water supply concepts to be further evaluated in the next project phase – Tier II Water Supply Concepts.

## 2.1 Concept Identification Process

Identification of the Tier I water supply concepts was conducted in two steps including those initially identified by the project team, and additional ones provided by the Cambria community residents during the March 15, 2012 Public Scoping Meeting.

### 2.1.1 Project Team Identified Water Supply Concepts

Because the CCC denied the consistency determination for a geotechnical investigation of the subterranean paleochannel at the Santa Rosa Creek beach area, the project team was not able to adequately define and analyze an earlier project alternative, which was to desalinate seawater withdrawn from horizontal wells under the seafloor. Following this set back, the project team consisting of CCSD’s District Engineer, USACE, engineering consultant CDM Smith, and environmental consultant Chambers Group, further expanded upon a number of concepts for the Cambria community water supply. A summary of the initially identified water supply concepts is presented in Table 2.1.1-1.

**Table 2.1.1-1 Initially Identified Cambria Community Water Supply Concepts**

No.	Water Supply Concept	Source of Water Supply
1	Shamel Park – Option 1	Ocean Seawater
2	Shamel Park – Option 2	Ocean Seawater
3	Shamel Park – Option 3	Ocean Seawater
4	Shamel Park – Option 4	Ocean Seawater
5	Lampton Park Open Ocean	Ocean Seawater
6	San Simeon Seawater – Option 1	Ocean Seawater
7	San Simeon Seawater – Option 2	Ocean Seawater
8	City of Morro Bay Shared Desalination Facilities	Ocean Seawater
9	Estero Bay Marine Terminal – Option 1	Ocean Seawater
10	Estero Bay Marine Terminal – Option 2	Ocean Seawater
11	Estero Bay Marine Terminal – Option 3	Ocean Seawater
12	San Simeon Creek Road Brackish Water – Option 1	Blend of percolated effluent, native basin water and deep aquifer brackish water
13	San Simeon Creek Road Brackish Water – Option 2	Blend of percolated effluent, native basin water and deep aquifer brackish water
14	San Simeon Creek Road Brackish Water – Option 3	Blend of percolated effluent, native basin water and deep aquifer brackish water
15	Lake Nacimiento Pipeline – Option 1	Lake surface water
16	Lake Nacimiento Pipeline – Option 2	Lake surface water
17	Whale Rock Reservoir with Lake Nacimiento Exchange Water	Lake surface water
18	Whale Rock Reservoir without Lake Nacimiento Exchange Water	Lake surface water and ground water from Cambria basin during winter wet season
19	Hard Rock Aquifer Storage and Recovery	Santa Rosa aquifer ground water

## 2.1.2 Additional Water Supply Concepts Identified During Public Scoping Meeting

In addition to the concepts developed by the project team, nine additional water supply concepts resulted from the EIS public scoping session process that included a scoping meeting held in Cambria on March 15, 2012, and the associated comment letters received in response to the Notice of Preparation. A summary of the additionally identified water supply concepts is presented in Table 2.1.1-2.

**Table 2.1.1-2 Cambria Community Water Supply Concepts Identified by Cambria Residents and Comment Letters in Response to EIR/EIS Notice of Preparation**

No.	Water Supply Concept	Source of Water Supply
1	Wastewater from the San Simeon Community	Recycled wastewater
2	Tropospheric Water Precipitation	Atmospheric water vapor
3	Naisetra Off-shore Seawater Desalination	Deep ocean seawater
4	Air Force Radar Storm Sewer Outfall Reuse	Ocean Seawater
5	Small Scale Storage Ponds	Creek surface water
6	Off-stream Canyon Storage	Creek surface water
7	Water Conservation	Conservation
8	Gray Water	Domestically used water
9	Capturing rainwater runoff	Rainwater

In a summary, there were a total of 28 water supply concepts identified by the project team, the Cambria community residents, and the related comments to the Notice of Preparation. As presented in the following sections, all 28 identified water supply concepts are briefly described and screened for technical feasibility. Eight concepts which passed the Tier I screening are carried over to the next project development phase identified herein as Tier II Water Supply Concepts.

## 2.2 Summary of Descriptions and Tier I Screening Results

Descriptions, technical feasibility assessment and recommendation for follow up considerations for the 28 above identified water supply concepts are presented in the following subsection of this TM.

### 2.2.1 Water Supply Concept 1 - Shamel Park Option 1

*Description* - Shamel Park Option 1 would use seawater as source of water supply, consisting of a subterranean seawater intake, a seawater pipeline, a SWRO desalination facility, a product water connection pipeline, concentrate return pumps and pipeline, and a subterranean concentrate return (see Figure 2.2.1-1). Three slanted wells constructed off-shore from the Shamel Park and placed in the sandy and gravely ocean floor immediately above the bedrock would provide for the subterranean ocean water intake. The SWRO plant would be located at the CCSD owned land parcel near the end of Heath Lane just west of their existing wastewater treatment plant (WWTP) operated by CCSD. The seawater pipeline would be laid along the Windsor Road and would serve to convey seawater to the SWRO facility. The concentrate return pipeline would follow generally the same route as the seawater intake pipeline and would be used to return the SWRO concentrate for its disposal back in the ocean. The horizontally directionally drilled (HDD) well would be used for SWRO subterranean concentrate disposal. The screened zone of the HDD well would be placed in subterranean sand and gravel deposits of the Paleochannel offshore from the mouth of Santa Rosa Creek, identified as Paleochannel C.



**Legend**

- Proposed SWRO Desalination Facility
- HDDW** Horizontal Directional Drilled Wells
- Existing CCSD's Water Distribution System Pipeline
- Product Water Pipeline
- Seawater Intake Pipeline
- Concentrate Return Pipeline
- - - Well Screen

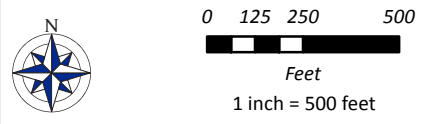

## Cambria Water Supply Technical Memorandum

**Figure 2.2.1-1**  
Water Supply Concept 1  
Shamel Park Option 1 Facility Layout



*Technical Feasibility Assessment* – Although currently available construction technology makes this option constructible, operational reliability of the Shamel Park Option 1 may be challenging. Sand layers above the shallow seawater intake wells could scour during storm events leaving the well screens exposed to the open ocean or to insufficient coverage. If not properly designed, the well screens could be blinded by suspended solids, seaweed and other debris, possibly reducing intake capacity and causing difficulties for SWRO operation.

*Recommendation* – Due to the similarities between all of the Shamel Park Options, Shamel Park Option 4 best meets the objectives and is recommended over Option 1.

## 2.2.2 Water Supply Concept 2 - Shamel Park Option 2

*Description* - Shamel Park Option 2 would use ocean seawater as the source of water supply, consisting of an engineered subterranean seawater intake gallery, a seawater pipeline, a seawater SWRO desalination facility, a product water connection pipeline, concentrate return pump and pipeline, and subterranean concentrate return HDD well (see Figure 2.2.2-1). The engineered intake gallery would be constructed in the ocean about 300 ft. off the Shamel Beach. Construction of the intake gallery would involve construction of 200 ft. long and 150 ft. wide coffer dam by driving steel sheet piles in the ocean floor all the way down to the bedrock. Upon completion of the coffer dam, the ocean floor would be excavated to the targeted depth of about 15 to 20 ft. below the native ocean floor. At the bottom of the excavated pit, a system of perforated under-drain pipes would be installed and backfilled with engineered sand and gravel layers that would filter the seawater before being transferred to the SWRO. The top of the pit would be backfilled with previously excavated native material from the ocean floor. Under the seawater hydrostatic pressure, the system of the perforated under drain pipes would be filled with the ocean water. A collector pipe would be installed to connect to the under drain piping system with the water intake pump station located on shore and constructed below grade. Seawater from the intake structure would be pumped to the SWRO facility. The Shamel Park Option 2 facilities, including a seawater pipeline, SWRO, product water pipeline, concentrate return pipeline and concentrate return HDD well, are similar or identical to the Shamel Park Option 1 facilities.

*Technical Feasibility Assessment* – Although proven as a reliable seawater intake concept (Long Beach, CA and Japan), implementation of this option is complicated, since the intake would need to be constructed from a barge in an open ocean environment. The intake could also be vulnerable to impacts from storms and ocean currents, removing the protective sand from above the intake structure or depositing silts which reduce the permeability and capacity of the gallery. In addition, high construction cost would make this option less attractive than the other three Shamel Park Options.

*Recommendation* - Due to the similarities among all of the Shamel Park Options, Shamel Park Option 4 best meets the objectives and is recommended over Option 2.

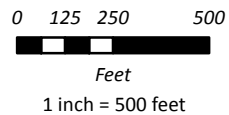

## Cambria Water Supply Technical Memorandum

**Figure 2.2.2-1**  
Water Supply Concept 2  
Shamel Park Option 2 Facility Layout



### 2.2.3 Water Supply Concept 3 - Shamel Park Option 3

*Description* - Shamel Park Option 3 would use seawater as the water supply source, consisting of a slant well as a subterranean seawater intake facility, a seawater pipeline, a SWRO desalination facility, a product water connection pipeline, concentrate return pumps and pipeline, and a subterranean concentrate return HDD well (see Figure 2.2.3-1). For this option, both a seawater intake slant well and concentrate return HDD well would be installed in the permeable sediments of Paleochannel C, offshore and well below the ocean floor. Entry pits for these two facilities would be located at the south west corner of Shamel Park. The associated subterranean drilling would be laid below SLO County owned portion of the Shamel Beach to avoid crossing under the natural preserve area of the adjacent state park property to the north. Screened portions of the slant well and HDD well would be located far-away from each other and designed in a manner not to impact each other's operation. The Shamel Park Option 3 facilities, including seawater pipeline, SWRO, product water pipeline, concentrate return pipeline and concentrate return HDD well, are similar or identical to Shamel Park Option 1 and 2 facilities (see the above descriptions).

*Technical Feasibility Assessment* – Both slant well and HDD well technologies are new with limited experience in the United States. A demo facility with a similar application in Dana Point, California is performing well, providing support to the technical feasibility for the slant well intake facility. Similarly, a number of HDD wells, also in similar applications, have been constructed in Europe. All other Option 3 facilities including SWRO are standard construction practice facilities.

*Recommendation* - Due to the similarities between all of the Shamel Park Options, Shamel Park Option 4 would best meet the objectives and is recommended over Option 3.

### 2.2.4 Water Supply Concept 4 - Shamel Park Option 4

*Description* - Shamel Park Option 4 consists of a subterranean seawater intake HDD well, a seawater pipeline, a SWRO desalination facility, a product water connection pipeline, concentrate return pumps and pipeline, and a subterranean concentrate return HDD well (see Figure 2.2.3-1). For this option, both seawater HDD well and concentrate return HDD well would be installed offshore and well below the ocean floor in the permeable sediments of Paleochannel C. Entry pits for these two facilities would be located at the Shamel Park parking lot northeast of the park. The associated subterranean HDD well drilling would be laid below Shamel Park and SLO County owned portion of the Shamel Beach to avoid the natural preserve State Parks property to the north. Screened portions of the intake and concentrate return HDD wells would be located far away from each other and designed in a manner to avoid impacting either facility's operation. The remaining Shamel Park – Option 4 facilities include a seawater pipeline, SWRO, product water pipeline, concentrate return pipeline and concentrate return HDD well, and would be similar or identical to the Shamel Park – Option 1, 2 and 3 facilities, as described in prior sections.

*Technical Feasibility Assessment* – Domestic and international experience with HDD well technology supports its application for the Cambria project, and unlike Option 3, Option 4 would utilize the same technology for both the seawater intake and concentrate return. If Shamel Park - Option 4 is selected for full scale implementation, a comprehensive hydrogeological investigation of the Paleochannel C and pilot testing seawater intake would be recommended to accurately define the design criteria for the HDD well and operating conditions for both the seawater intake and concentrate return. All other Option 4 facilities, including SWRO, pipelines and pumping facilities are based on standard construction practice.





**Legend**

- Proposed SWRO Desalination Facility
- HDDW Horizontal Directional Drilled Wells
- Existing CCSD's Water Distribution System Pipeline
- Product Water Pipeline
- Seawater Intake Pipeline
- Concentrate Return Pipeline
- Well Screen

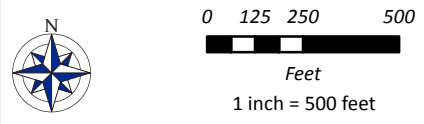

## Cambria Water Supply Technical Memorandum

**Figure 2.2.3-1**  
Water Supply Concepts 3 and 4  
Shamel Park Options 3 and 4 Facility Layouts



*Recommendation* - Shamel Park Option 4 is recommended to be carried over to the Tier II Water Supply Concepts for further development and evaluation.

### 2.2.5 Water Supply Concept 5 - Lampton Park

*Description* – The Lampton Park Concept would use seawater as a source of water supply, consisting of a seafloor mounted open ocean intake, a seawater pipeline, a SWRO desalination facility, a product water connection pipeline, concentrate return pumps and pipeline, and a seafloor mounted concentrate return outfall (see Figure 2.2.5-1). The wedge screen open ocean intake would be constructed from an entry pit located at Lampton Park, and would use the HDD technology to install the seawater intake pipe below the ocean floor. The seawater intake would exit in the ocean outside the State Marine Conservation Area (SMCA) border line. The open ocean concentrate return would consist of an outfall pipe and concentrate diffuser. The outfall pipe would be constructed by using the HDD technology with a pipeline insertion pit at Lampton Park and an exit pit outside the SMCA border line and about 2,500 ft. south of the seawater intake. The on-shore reaches of the seawater and concentrate return pipelines would be laid along the Cambria streets and the existing CCSD's emergency access roadway. The SWRO plant would be located at the CCSD owned land parcel just west of their existing WWTP.

*Technical Feasibility Assessment* – Implementation of the Lampton Park Concept would face multiple difficulties, including limited space at the public park. Visual inspection of the soil conditions indicated very hard, possibly volcanic rocks below the ocean floor which would render HDD not feasible for the construction of seawater intake and concentrate return facility.

*Recommendation* - Lampton Park Concept is not recommended to be carried over for Tier II development and evaluation.

### 2.2.6 Water Supply Concept 6 - San Simeon Old Village Seawater Option 1

*Description* – The San Simeon Seawater Option 1 would use seawater as a water supply source, consisting of a subterranean seawater intake, a seawater pipeline, a SWRO desalination facility, a product water connection pipeline, concentrate return pumps and pipeline, and a subterranean ocean concentrate return (see Figure 2.2.6-1). The subterranean seawater intake would be constructed by implementing an HDD well in the fractured Monterey Shale Formation at the small peninsula located approximately 3/4 of a mile north from the Old San Simeon Village area. The access pit for construction of the HDD well would be located at the corner of SLO San Simeon Road within the Old Village area, avoiding any surface construction activities within the wooded area of the peninsula. A 6.5 mile long seawater pipeline would be laid along PCH and San Simeon Creek Road, and would connect the seawater intake with the SWRO plant proposed to be located on the CCSD owned land next to the existing WWTP effluent percolation ponds. Seawater concentrate return would occur off of a CCSD-owned Flag Lot, which is north of the San Simeon Creek beach area, and would restore a 1996 era constructed subterranean horizontal well. The concentrate return pipeline would connect the SWRO plant with the proposed concentrate return facility, and would be laid out along San Simeon Road and a short reach of Lone Palm Drive.

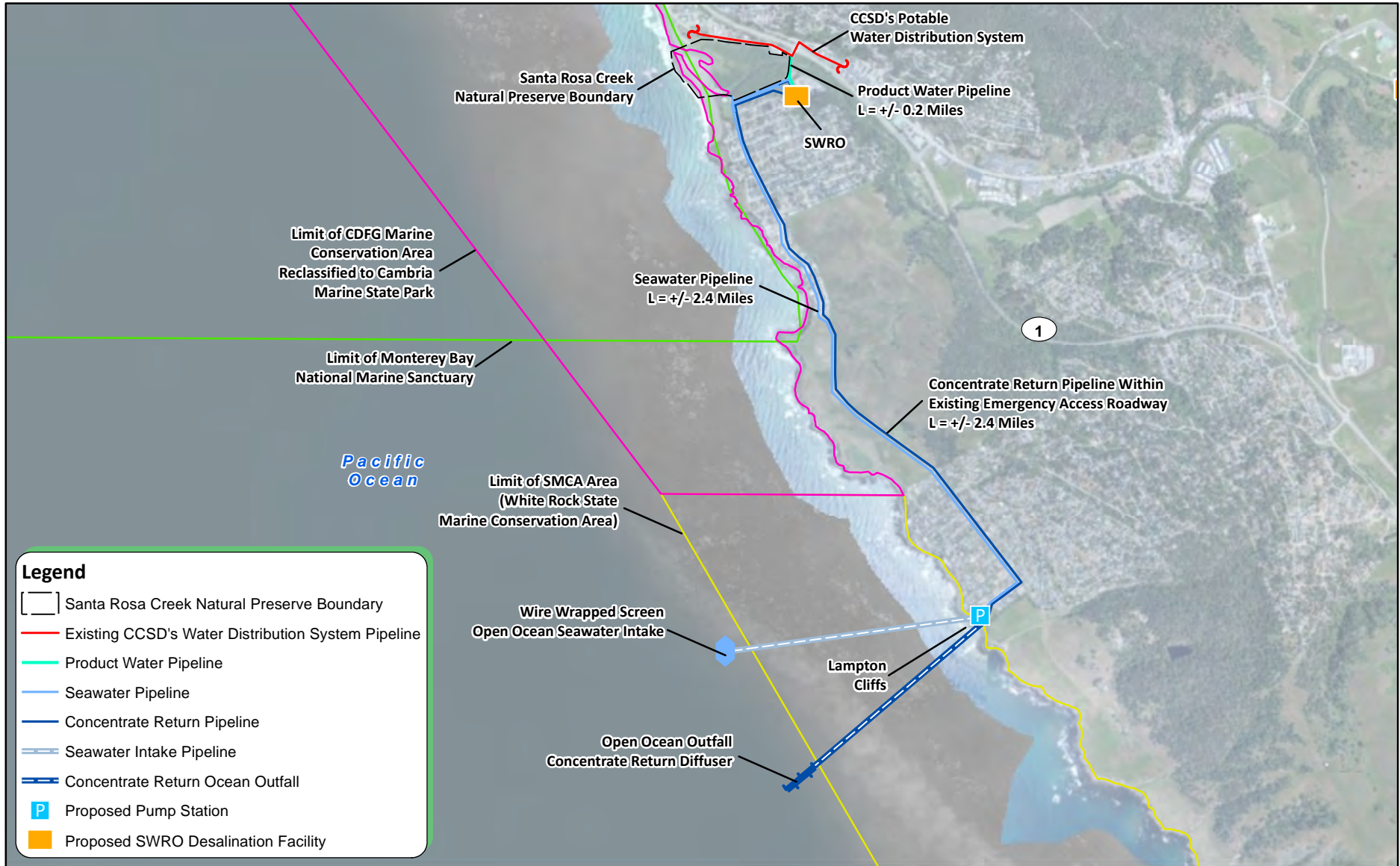

**Figure 2.2.5-1**  
 Water Supply Concept 5  
 Lampton Park Concept Facility Layout

## Cambria Water Supply Technical Memorandum

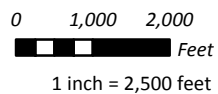

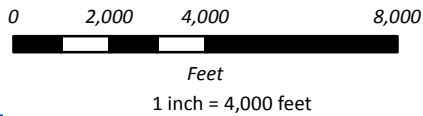
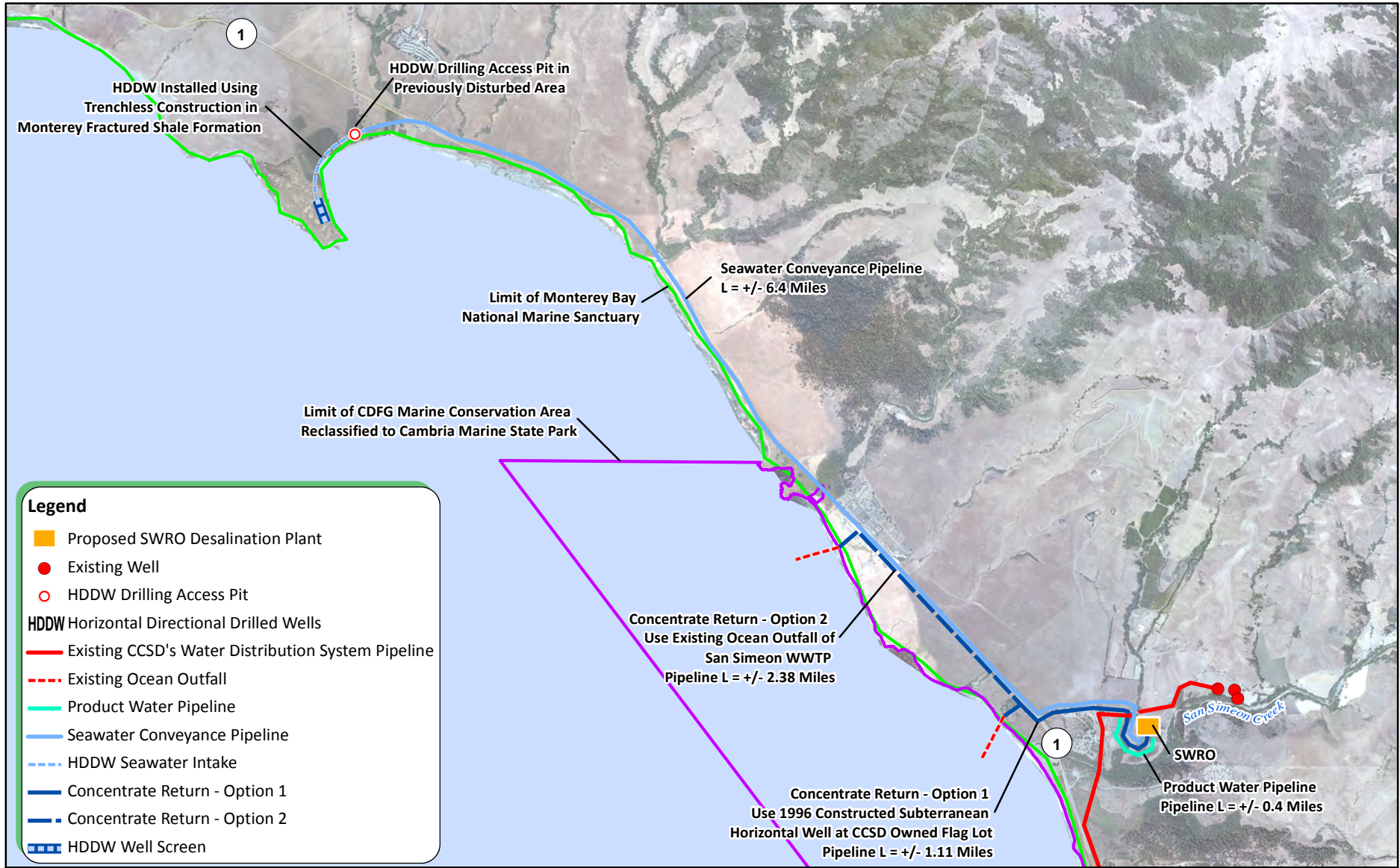

# Cambria Water Supply Technical Memorandum

**Figure 2.2.6-1**  
Water Supply Concepts 6 and 7  
San Simeon Village Seawater  
Options 1 and 2 Facility Layouts

*Technical Feasibility Assessment* – Initial research of the available hydro-geological data and a field reconnaissance visit at the site for the proposed subterranean seawater intake indicated that the fractured shale formation would not yield targeted flows for the Cambria water supply project. Due to the relatively low yield potential, it was deemed impractical to conduct extensive and expensive geotechnical, geophysical and hydro-geological investigations.

*Recommendation* - The San Simeon Seawater Option 1 is not recommended to be carried over for the Tier II development and evaluation.

### 2.2.7 Water Supply Concept 7 - San Simeon Old Village Seawater Option 2

*Description* – The San Simeon Seawater Option 2 would use the same source of water supply as Option 1 consisting of a subterranean seawater intake, a seawater pipeline, a SWRO desalination facility, a product water connection pipeline, concentrate return pumps and pipeline, and a subterranean ocean concentrate return (see Figure 2.2.6-1). All facilities, except the concentrate return pipeline and ocean subterranean concentrate return are identical to those of the San Simeon Seawater Option 1. For Option 2, the concentrate return pipeline from the SWRO plant would connect into an existing open ocean outfall that discharges treated wastewater from the existing San Simeon CSD WWTP. The concentrate return pipeline would be laid out along San Simeon Road and PCH.

*Technical Feasibility Assessment* – Initial research of the available hydro-geological data and a field reconnaissance visit at the site for the proposed subterranean seawater intake indicated that the fractured shale formation would not yield enough flow for the Cambria water supply project. Due to the relatively low yield potential, it was deemed impractical to conduct extensive and expensive geotechnical, geophysical and hydro-geological investigations.

*Recommendation* - The San Simeon Seawater Option 2 is not recommended to be carried over for further Tier II development and evaluation due to sensitivity of the area for its implementation.

### 2.2.8 Water Supply Concept 8 - City of Morro Bay Shared Desalination Facility

The City of Morro Bay, located about 18 miles south of Cambria, owns and operates a SWRO facility. The facility is operational with some issues of seawater pretreatment, but has the potential for a capacity increase that would be sufficient for the Cambria water supply project. The City of Morro Bay Shared Desalination Facilities concept would consist of new beach wells, new seawater pipeline, remodeled and upgraded existing SWRO plant, new concentrate return pipeline and new product water pipeline (see Figure 2.2.8-1). There would be three to five new beach wells laid out along Coleman Drive and southwest of the Embarcadero street, which would provide raw seawater for treatment. A new pipeline along Coleman Drive and Atascadero Road would be constructed to transfer seawater from the new beach wells to the existing SWRO plant. The existing SWRO plant would be upgraded to address current pretreatment issues, to improve plant efficiency through energy recovery, and to provide treatment capacity for Cambria water supply. The plant's SWRO concentrate would be returned back into the ocean via the existing power plant cooling water return canal and a new concentrate return pipeline. The SWRO product water would be conveyed to the Cambria water distribution system via a new 18.3 mile long product water pipeline that would be constructed along PCH within Caltrans' right-of-way (ROW).



**Legend**

- Existing Morro Bay SWRO Treatment Plant
- Coastal Zone Boundary
- Existing CCSD's Water Distribution Pipeline
- Concentrate Return Pipeline
- Seawater Pipeline
- Product Water Pipeline
- Existing Morro Bay SWRO Desalination Plant Expansion
- Seawater Beach Well

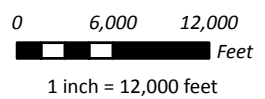

# Cambria Water Supply Technical Memorandum

**Figure 2.2.8-1**  
Water Supply Concept 8  
City of Morro Bay Shared SWRO Facility Layout



*Technical Feasibility Assessment* – The proposed new beach wells would be located in the same geological formation as the existing City of Morro Bay wells. There are readily available technologies that would address the identified pretreatment issues and provide an efficient operation of the upgraded SWRO plant. The product water pipeline would follow PCH and cross through different geological formation and geographies, but its construction and operational challenges would be within reasonable ranges.

*Recommendation* - The City of Morro Bay Shared Desalination Facilities concept is recommended to be carried over to the Tier II Water Supply Concepts for further development and evaluation.

### 2.2.9 Water Supply Concept 9 - Estero Bay Marine Terminal Option 1

*Description* – The Estero Bay Marine Terminal Concept 9, Option 1 would use seawater as a water supply source, consisting of beach wells at the City of Morro Bay beach well site, a seawater pipeline, SWRO desalination facility, a product water conveyance pipeline, and concentrate return pumps and pipeline (see Figure 2.2.9-1). The seawater beach wells would also be located in the City of Morro Bay along Coleman Drive and southwest of Embarcadero Street. The SWRO plant would be located inland off Toro Creek Road, approximately one mile east of PCH and outside of the Coastal Zone boundary. The seawater pipeline would run along the City of Morro Bay streets including Coleman Drive, Embarcadero and Atascadero Road. The pipeline would then turn to the north along PCH and then east along Toro Creek Road. The concentrate return pipeline would follow the same alignment as the seawater pipeline and would discharge SWRO concentrate into the existing power plant cooling water return canal. The SWRO product water would be conveyed to the Cambria water distribution system via the new product water pipeline. The product water conveyance pipeline would start from the SWRO plant and would be laid out westerly approximately one mile along Toro Creek Road. It would then turn northerly along PCH within Caltrans' ROW, a distance of 16.1 miles.

*Technical Feasibility Assessment* – The proposed new beach wells would be the same as described for the City of Morro Bay Shared Desalination Facilities concept and would reliably provide raw seawater for the Cambria water supply project. The new SWRO plant would be located outside of the Coastal Zone boundary. Similar to the City of Morro Bay Shared Desalination Facilities concept, the product water pipeline would cross through different geological formations and geographies, but its construction and operational challenges would be within reasonable ranges. Although constructible, implementation of the concentrate return pipeline would face some additional challenges when constructed along the streets of Morro Bay.

*Recommendation* - Because the Estero Bay Marine Terminal Option 3 has shorter seawater pipeline and meets the objectives better than Option 1, the Estero Bay Marine Terminal Option 1 is not recommended to be carried over for the Tier II Water Supply Concepts for further development and evaluation.

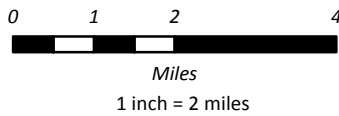

## Cambria Water Supply Technical Memorandum

**Figure 2.2.9-1**  
Water Supply Concepts 9, 10 and 11  
Estero Bay Marine Terminal Concept  
Options 1, 2 and 3 Facility Layouts



### 2.2.10 Water Supply Concept 10 - Estero Bay Marine Terminal Option 2

*Description* – The Estero Bay Marine Terminal Concept 10, Option 2 would use seawater as its water supply source, and would consist of an open ocean seawater intake, a seawater pipeline, a SWRO desalination facility, a product water conveyance pipeline, concentrate return pumps and pipeline, and an open ocean outfall (see Figure 2.2.9-1). A currently abandoned Chevron Corporation’s crude oil tanker loading pipeline would be rehabilitated and retrofitted by placing a wire wrapped screen intake at the ocean floor so that it would work as an open ocean seawater intake as the supply source for SWRO treatment. As with Estero Bay Marine Terminal Option 1, the SWRO plant would be located off Toro Creek Road approximately one mile east of PCH and outside of the Coastal Zone boundary. The seawater pipeline alignment would run along Toro Creek Road connecting the seawater intake with the SWRO plant. The concentrate return pipeline would follow the same alignment as the seawater pipeline, and discharge the brine through the retrofitted existing marine terminal outfall. The product water conveyance pipeline would be the same as that described for the Estero Bay Marine Terminal Option 1.

*Technical Feasibility Assessment* – Feasibility of this concept is questionable because alignment and physical conditions of the Chevron Corporation abandoned oil pipelines are unknown. In addition, the Coastal Commission and State Lands Commission have required the Chevron Corporation to remove the abandoned oil pipes, which could happen in the near future before CCSD makes a final selection of the option for their Cambria water supply project.

*Recommendation* - The Estero Bay Marine Terminal Option 2 is not recommended to be carried over for the Tier II Water Supply Concepts for further development and evaluation. Estero Bay Marine Terminal Option 3 would meet the objectives better than Option 2, and not be subject to the existing pipeline removal requirements

### 2.2.11 Water Supply Concept 11 - Estero Bay Marine Terminal Option 3

*Description* – The Estero Bay Marine Terminal Option 3 would use source water supply from the same location as in Option 2, consisting of a subterranean HDD well seawater intake, a seawater pipeline, a SWRO desalination facility, a product water conveyance pipeline, and concentrate return pump and pipeline same as concentrate return Option 1 (see Figure 2.2.9-1). The HDD seawater intake well would be installed offshore below the ocean floor in permeable sediments of a Paleochannel extending off shore from the Toro Creek mouth. Entry pits for the HDD well would be located east of PCH and would cross underneath the existing Dog Beach area without any beach disturbance. The seawater pipeline would be aligned along Toro Creek Road easterly from the HDD well entry pit. As with Estero Bay Marine Terminal Options 1 and 2, the SWRO plant would be located off Toro Creek Road and inland from the Coastal Zone boundary. The SWRO concentrate would be returned back to the ocean via the existing Morro Bay power plant cooling water return canal. The concentrate pipeline would be laid westerly from the SWRO plant along Toro Creek Road and southerly along PCH, and then through the streets of Morro Bay to the connection with the power plant cooling water return canal. The product water conveyance pipeline would have the same alignment as that described for the above Estero Bay Marine Terminal Options 1 and 2.

*Technical Feasibility Assessment* – A geotechnical report would be needed to specifically confirm the existence and underground characteristics of the Toro Creek paleochannel. Such information would be critical in further defining and determining the feasibility of this water supply concept. The other project facilities, including SWRO plant, concentrate return and associated pipeline are technically feasible and could be constructed within acceptable costs.

*Recommendation* - The Estero Bay Marine Terminal Option 3 is recommended to be carried over in Tier II Water Supply Concepts for further development and evaluation.

### 2.2.12 Water Supply Concept 12 - San Simeon Creek Road Brackish Water Option 1

*Description* - The San Simeon Creek Road Brackish Water Concepts would extract, treat and use brackish ground water resulting from the mixture of seawater that has migrated inland within a subterranean saltwater wedge, groundwater from the San Simeon aquifer, and recycled water that has percolated through the CCSD's treated wastewater effluent percolation ponds. The proposed San Simeon Creek Road Brackish Water Option 1 would consist of existing percolation ponds, new brackish water extraction wells, a new advanced water treatment plant (AWTP), a product water connecting pipeline, and a new AWTP generated concentrated brackish water disposal system at a CCSD owned Flag Lot (see Figure 2.2.12-1). There are three existing percolation ponds that would continue receiving and percolating secondary effluent generated by the CCSD-owned WWTP into the basin. The new ground water extraction wells would be located immediately east of the existing CCSD's percolation ponds and provide source water for the AWTP. The extracted ground water would be a blend of the percolated secondary effluent, native San Simeon basin water and deep aquifer brackish water from an inland saltwater wedge. The AWTP would be located on the CCSD owned land, just north of the existing percolation pond, and be capable of removing salinity and other known and unknown water constituents that may be present in the extracted ground water. The finished product water pipeline would directly connect the AWTP with the potable water supply pipeline, which is currently delivering water from the San Simeon potable wells to the Cambria community distribution system. Brine from the AWTP would be conveyed for subterranean ocean return, via a new brine pipeline, before connecting into a restored 1996-era horizontal well at the CCSD owned Flag Lot.

*Technical Feasibility Assessment* - Although more investigative work would be required for full scale application, a 1998 United States Geological Survey (USGS) prepared basin model and results support a reliable assumption that this water supply concept is technically and economically feasible. However, the physical conditions and hydrogeological characteristics of the 1996 constructed horizontal well at the Flag Lot are unknown and possibly not usable for this application. Also, the proximity of the ground water extraction wells to the secondary effluent percolation ponds and direct potable use of the AWTP product water would require an extensive and long permitting process.

*Recommendation* - The San Simeon Creek Road Brackish Water Option 1 is not recommended to be carried over in Tier II Water Supply Concepts for further development and evaluation. The San Simeon Creek Road Brackish Water Option 3 would better meet the objectives than Option 1.

### 2.2.13 Water Supply Concept 13 - San Simeon Creek Road Brackish Water Option 2

*Description* - The proposed San Simeon Creek Road Brackish Water Option 2 would use the same water supply source as Option 1, and would consist of the existing percolation ponds, new brackish water extraction wells, a new AWTP, product water recharge pipeline and injection wells, and an AWTP generated concentrated brackish water disposal at the existing San Simeon Community WWTP outfall (see Figure 2.2.12-1). Percolation ponds, ground water extraction wells, and AWTP are the same as described for Water Supply Concept 12. The finished product water would be piped from the AWTP to the existing San Simeon Basin potable water well field. The proposed new injection wells would recharge the finished product water in the basin for a minimum of two months retention before entering extraction wells serving the Cambria community water supply.

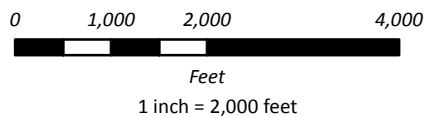
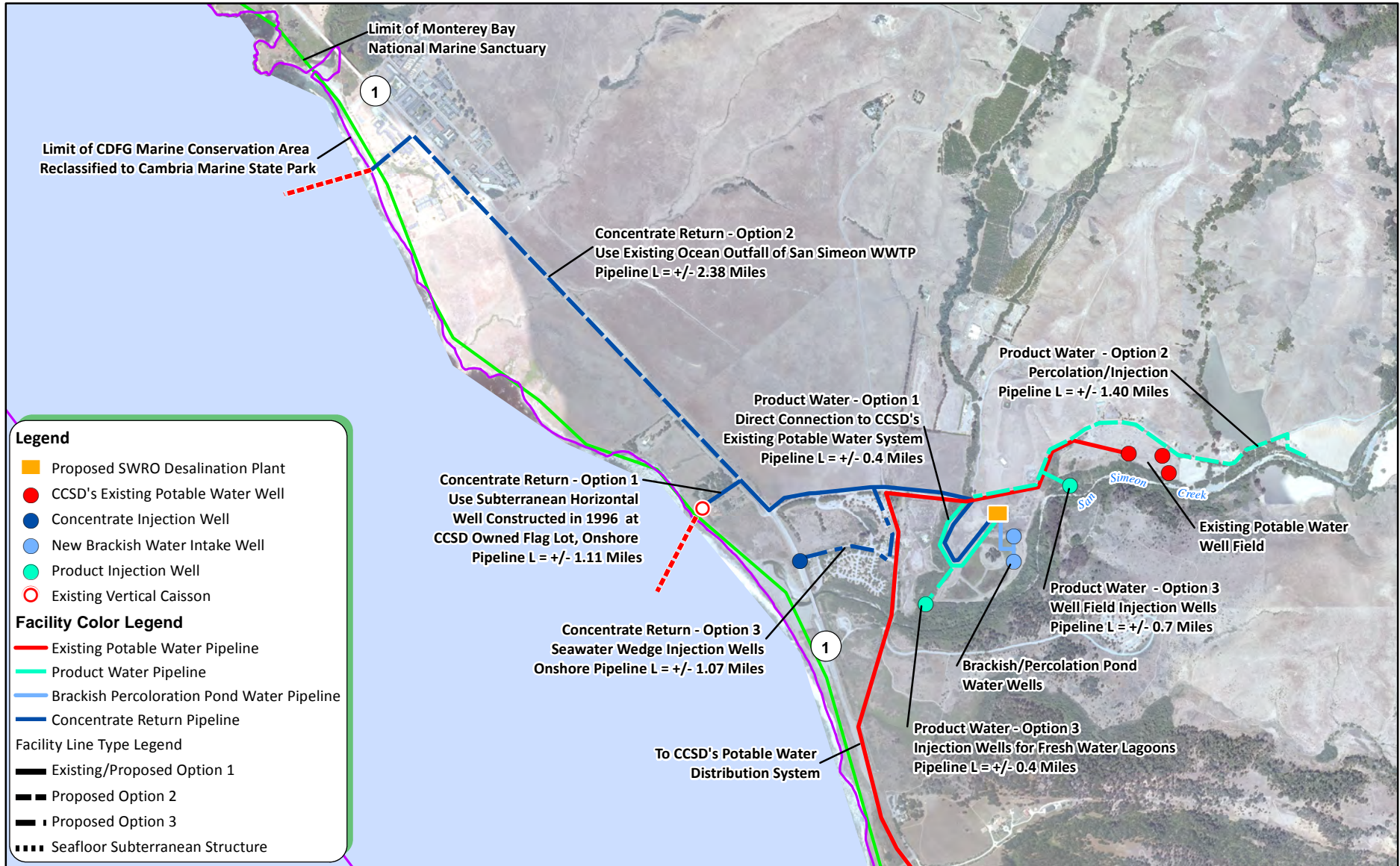

## Cambria Water Supply Technical Memorandum

**Figure 2.2.12-1**  
Water Supply Concepts 12, 13 and 14  
San Simeon Creek Road Brackish Water Concept  
Options 1, 2 and 3 Facility Layouts

Concentrated brackish water from the AWTP would be conveyed to the existing San Simeon Community WWTP for ocean disposal via the existing WWTP ocean outfall. Alignment of the concentrated brackish water pipeline would start from the AWTP and would extend westerly along the San Simeon Creek Road and northerly along PCH.

*Technical Feasibility Assessment* – As described for San Simeon Creek Road Brackish Water Option 1, hydrogeological conditions provide for reliable assumptions that this water supply concept is technically and economically feasible. While the technical feasibility is proven, a long brine pipeline along PCH and an uncertain permitting process for open ocean brine disposal would add implementation complexity for this concept.

*Recommendation* - The San Simeon Creek Road Brackish Water Option 2 is not recommended to be carried over in Tier II Water Supply Concepts for further development and evaluation. The San Simeon Creek Road Brackish Water Option 3 would better meet the objectives than Option 2.

### 2.2.14 Water Supply Concept 14 - San Simeon Creek Road Brackish Water Option 3

*Description* – The proposed San Simeon Creek Road Brackish Water Option 3 would also use the same water supply source as Option 1, consisting of the existing percolation ponds, new brackish water extraction wells, new AWTP, product water recharge pipeline and injection wells, and an AWTP-generated concentrated brackish water disposal well system that would discharge into the subterranean saltwater wedge (see Figure 2.2.12-1). The percolation ponds, ground water extraction wells, and AWTP are the same as described for San Simeon Creek Road Brackish Water Option 1. The finished product water would be piped from the AWTP to the existing San Simeon Basin potable water well field. The proposed new injection wells would recharge the finished product water in the basin for a minimum of two months retention before entering extraction wells serving the Cambria community water supply. Brine from the AWTP would be conveyed to the two new brine injection wells located along PCH for disposal into the subterranean saltwater wedge. Alignment of the brine pipeline would start from the AWTP and would extend westerly along the San Simeon Creek Road, then would turn southerly on Van-Gordon Creek Road and again westerly on San Simeon State Park.

*Technical Feasibility Assessment* – As described for San Simeon Creek Road Brackish Water Option 1, and based on the 1998 USGS basin modeling results, hydrogeological conditions provide for reliable assumptions that this water supply concept is technically and economically feasible. As with Options 1 and 2, the product water injection wells would provide for two month retention time before being pumped by wells serving the Cambria community water supply. Finally, the proposed brine recharge into the subterranean saltwater wedge would improve basin protection against seawater intrusion during the dry season.

*Recommendation* - The San Simeon Creek Road Brackish Water Option 3 is recommended to be carried over in Tier II Water Supply Concepts for further development and evaluation.

### 2.2.15 Water Supply Concept 15 - Lake Nacimiento Pipeline Option 1

The County of SLO has entitlements on water rights of 17,500 acre foot per year (AFY) from the existing Lake Nacimiento Reservoir. As a community of the County, during 1990's, CCSD has requested water rights to pump 2,000 AFY of the water from the Lake, which would be conveyed to the San Simeon Creek watershed via an independent pipeline.

***Description*** – The proposed Lake Nacimiento Pipeline Option 1 would consist of a new water intake at the existing Lake Nacimiento, a water conveyance pipeline with multiple booster pump stations, and a water discharge structure in the San Simeon Creek watershed (see Figure 2.2.15-1). The new water intake structure would be constructed in the lake and located approximately three miles southwest of the Lake Nacimiento dam. The lake water intake would be furnished with a fish screen that would protect fish and prevent debris from entering into the conveyance system. A new pump station with an oversized wet well that would work as an intake holding tank, would be an integral part of the intake structure. The water conveyance pipeline would be laid westerly across Santa Lucia Mountains in an alignment known as Franklin Creek Pipeline Route. Due to an elevation difference of 1,760 ft. between the lake water elevation and the highest pipeline elevation, three booster pump stations would be constructed along the conveyance pipeline.

The conveyed water would be discharged in the Steiner Creek from where it would flow downstream to the new proposed Palmer Flats well field. The extraction wells at the Palmer Flats well field would extract and pump water via a new Palmer Flats Water Transfer Pipeline for Cambria water supply.

***Technical Feasibility Assessment*** – Although technically feasible, implementation of the Lake Nacimiento Pipeline Option 1 would face multiple challenges. A pipeline across the Santa Lucia Mountain range would cross different geographies, environmental conditions and geological formations, and would require construction of key infrastructure, such as temporary construction and permanent maintenance roads, and power supply lines. Construction and operation and maintenance (O&M) costs would be high, making this concept financially inefficient.

***Recommendation*** - The Lake Nacimiento Pipeline Option 1 is not recommended to be carried over in Tier II Water Supply Concepts for further development and evaluation.

## 2.2.16 Water Supply Concept 16 - Lake Nacimiento Pipeline Option 2

***Description*** – Similar to Lake Nacimiento Pipeline Option 1, the proposed Lake Nacimiento Pipeline Option 2 would consist of a new water intake at the existing Lake Nacimiento, a water conveyance pipeline with multiple booster pump stations, and a water discharge structure in the San Simeon Creek watershed (see Figure 2.2.15-1). The new water intake structure would be constructed in the lake and located approximately 3.5 miles southwest of the Lake Nacimiento dam. Engineering concepts for the water intake and pump station are the same as that described for the Lake Nacimiento Pipeline Option 1. The water conveyance pipeline would be laid westerly across Santa Lucia Mountains in an alignment known as Town Creek Pipeline Route. Due to an elevation difference of 1,900 ft. between the lake water elevation and the highest pipeline elevation, three booster pump stations would be constructed along the conveyance pipeline. The conveyed water would be discharged in the upper San Simeon Creek from where it would flow downstream to the new proposed Palmer Flats well field. The extraction wells at the Palmer Flats well field would extract and pump water via a new Palmer Flats Water Transfer Pipeline for Cambria water supply.

***Technical Feasibility Assessment*** – Although technically feasible, implementation of the Lake Nacimiento Pipeline Option 2 would face multiple challenges. As with Lake Nacimiento Pipeline Option 1, a pipeline across the Santa Lucia Mountain range would cross different and challenging construction geographies, environmental conditions and geological formation. Implementation of this water supply option would require construction of key infrastructure such as temporary construction and permanent maintenance roads, and power supply lines. Construction, and O&M cost would be high, making this concept financially inefficient.

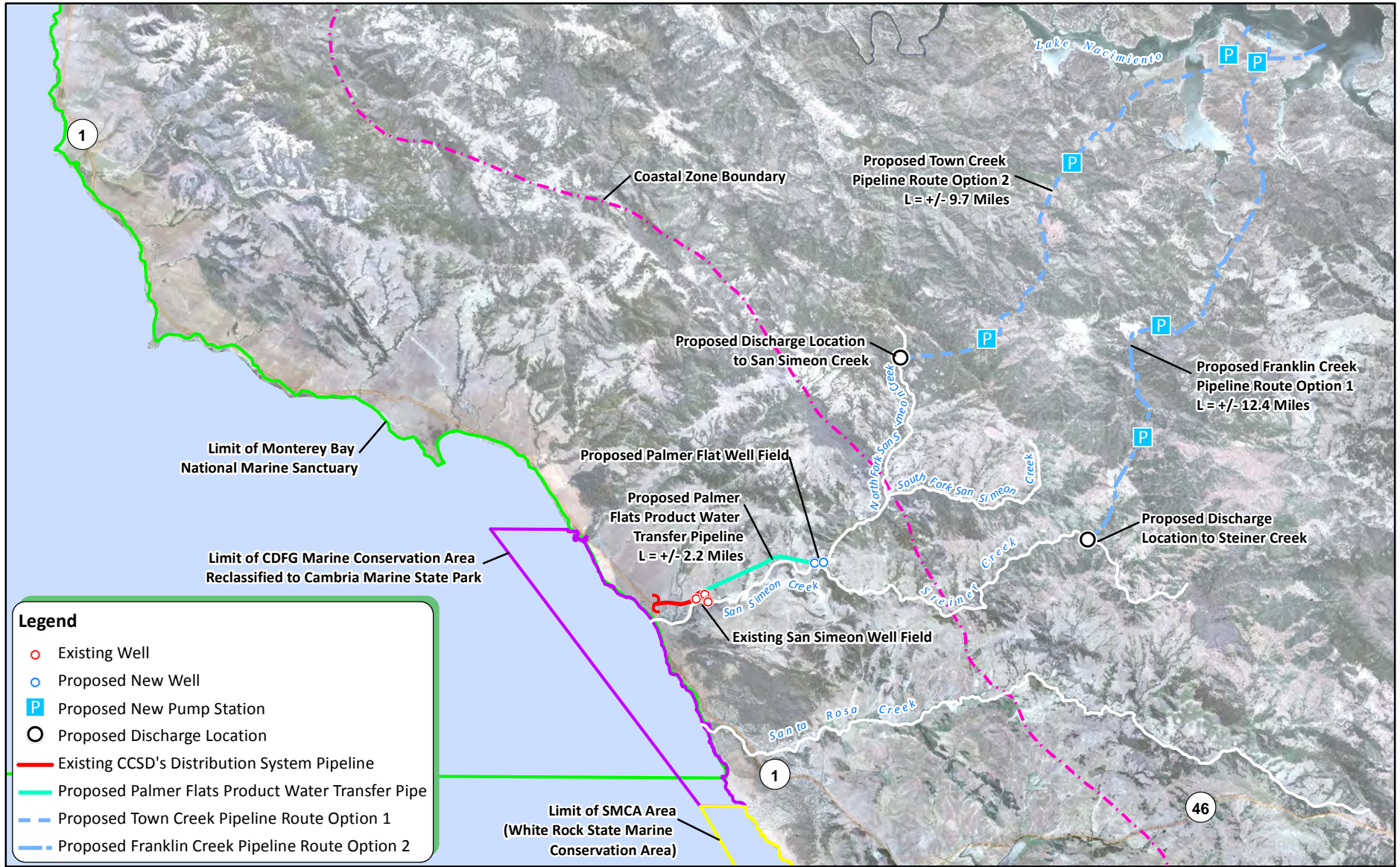

**Legend**

- Existing Well
- Proposed New Well
- P Proposed New Pump Station
- Proposed Discharge Location
- Existing CCSD's Distribution System Pipeline
- Proposed Palmer Flats Product Water Transfer Pipe
- Proposed Town Creek Pipeline Route Option 1
- Proposed Franklin Creek Pipeline Route Option 2

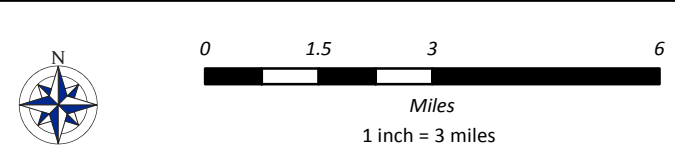

# Cambria Water Supply Technical Memorandum

**Figure 2.2.15-1**  
Water Supply Concepts 15 and 16  
Lake Nacimiento Pipeline Option 1 and 2 Facility Layout



***Recommendation*** - The Lake Nacimiento Pipeline Option 2 is not recommended to be carried over in Tier II Water Supply Concepts for further development and evaluation.

### 2.2.17 Water Supply Concept 17 - Whale Rock Reservoir with Lake Nacimiento Water Exchange

***Description*** - Under the Whale Rock Reservoir Exchange concept, CCSD would exchange water rights in Lake Nacimiento with the City of San Luis Obispo for water rights in Whale Rock Reservoir. To provide means for water rights exchange, CCSD would purchase an entitlement of the existing Nacimiento water project pipeline. The City would access the CCSD's Lake Nacimiento exchange water at the SLO WTP at Stenner Creek Road via their existing Lake Nacimiento Water Pipeline connection. Through this exchange, the CCSD would use the equivalent water volume from the existing Whale Rock Reservoir for Cambria's water supply. The Whale Rock Reservoir Exchange water supply option would involve the existing Lake Nacimiento water pipeline, the existing SLO WTP, and the existing SLO Pipeline that connects the plant with the Whale Rock Reservoir, the existing Whale Rock Reservoir, and the new surface WTP and the treated water pipeline to supply water to the Cambria community during dry season (see Figure 2.2.17-1). The existing and new proposed facilities of the Whale Rock Reservoir with Lake Nacimiento Water Exchange water supply concept are shown in Figure 2.2.17-1. The new Cambria WTP would be constructed in Cayucos close to the Whale Rock Dam, and designed as a typical surface filtration plant consisting of screening, coagulation, direct filtration, filter water polishing, and disinfection. The treated water pipeline would be used to transfer treated water from the Cambria WTP to the Cambria community distribution system. The pipeline would be laid along PCH, within the California Department of Transportation (Caltrans) ROW.

***Technical Feasibility Assessment*** - Most of the Whale Rock Exchange water supply facilities are existing and operational. The new surface WTP would be a common facility and its construction, O&M would not pose any technical challenges. The treated water pipeline would cross through different geographies and geological formations, but its construction and operational challenges would be within reasonable ranges.

***Recommendation*** - The Whale Rock Exchange is not recommended to be carried over in Tier II Water Supply Concepts for further development and evaluation because implementation of this concept would require extensive negotiations and agreement with the City and County of SLO, as well as with the Department of Water Resources (DWR).

### 2.2.18 Water Supply Concept 18 - Whale Rock Reservoir without Lake Nacimiento

***Description*** - Whale Rock Reservoir without Lake Nacimiento (also known as Whale Rock Reservoir Concept) would extract, pump and store groundwater from the Santa Rosa and San Simeon Creek aquifers into the Whale Rock Reservoir during the winter, which would be used as a potable water supply to the Cambria community during the dry season. The Whale Rock Reservoir concept would involve the existing CCSD potable water wells in the San Simeon Creek and Santa Rosa Creek basins, existing CCSD water distribution network, a new Cambria Pump Station, a new water conveyance pipeline, the existing Whale Rock Reservoir, and a new surface WTP (see Figure 2.2.18-1).

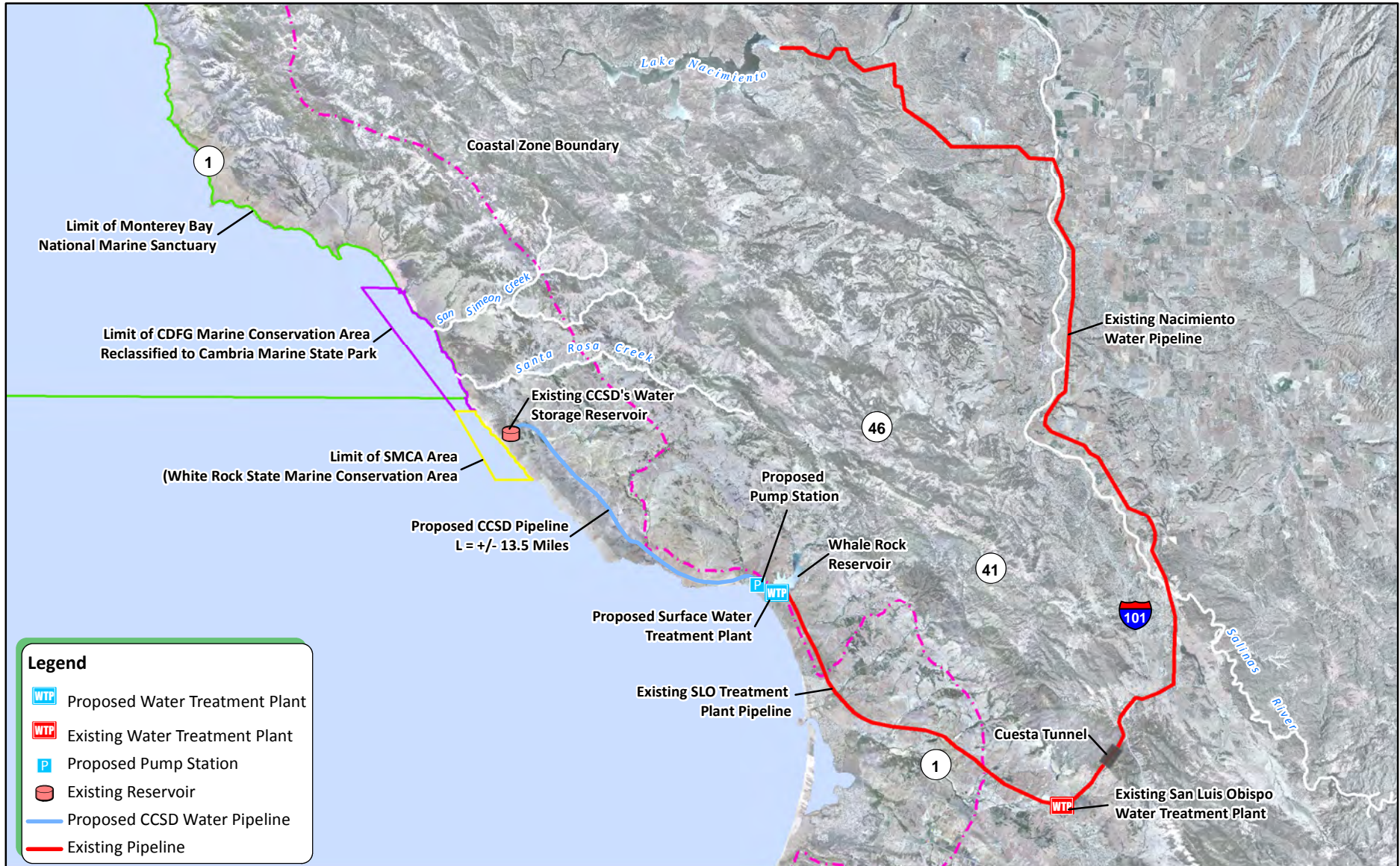

**Legend**

- Proposed Water Treatment Plant
- Existing Water Treatment Plant
- Proposed Pump Station
- Existing Reservoir
- Proposed CCSD Water Pipeline
- Existing Pipeline

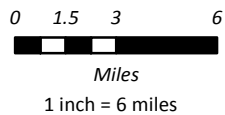

## Cambria Water Supply Technical Memorandum

**Figure 2.2.17-1**  
Water Supply Concept 17  
Whale Rock Reservoir with Lake Nacimiento  
Water Exchange Facility Layout





**Legend**

- - - Coastal Zone Boundary
- CCSD's Existing Water Distribution System Pipeline
- Existing Raw Water Pipeline
- CCSD Water Discharge Pipeline
- Water Transmission Pipeline
- P Proposed Cambria - Whale Rock Pump Station
- WTP Existing Cayucos Water Treatment Plant
- WTP Proposed Water Treatment Plant



0 4,000 8,000



Feet

1 inch = 8,000 feet

## Cambria Water Supply Technical Memorandum

**Figure 2.2.18-1**  
Water Supply Concept 18 Whale Rock Reservoir  
Without Lake Nacimiento Facility Layout



Under wet weather flow conditions the existing potable water wells would pump water in excess of water demand for the Cambria community. The excess water would be transferred through the existing Cambria water distribution piping system and discharged into a wet well of the proposed Cambria Pump Station located west of PCH at the southeast tip of the Cambria community. The new water conveyance pipeline would be laid along PCH in the Caltrans ROW, and convey the excess water from the Cambria Pump Station to the Whale Rock Reservoir. The new surface WTP would be located in Cayucos just downstream of the Whale Rock dam, and would treat the Whale Rock Reservoir stored water to meet Cambria Community water needs. As an integral part of the new WTP, a product water pump station would pump the treated water back to Cambria by means of the same new water conveyance pipeline.

*Technical Feasibility Assessment* – The Whale Rock Reservoir Concept maximizes the use of existing facilities, including the CCSD’s potable water wells, the CCSD’s distribution network and the Whale Rock Reservoir, which is owned by the Whale Rock Commission member agencies. Implementation of the proposed new facilities, including the Cambria Pump Station, a water conveyance pipeline, and a surface WTP, would require standard construction methods and routine O&M practices. Construction and O&M costs for this concept would render the cost of the water to the community within the range of costs for water served in the Central Coast and Southern California.

*Recommendation* - The Whale Rock Reservoir Concept is recommended to be carried over in Tier II Water Supply Concepts for further development and evaluation.

### 2.2.19 Water Supply Concept 19 - Hard Rock Aquifer Storage and Recovery

*Description* – The Hard Rock Aquifer Storage and Recovery (ASR) concept would store ground water extracted during winter months from the Santa Rosa Creek aquifer into a confined Hard Rock Aquifer for summertime use as a potable water supply. This concept involves the existing Santa Rosa Creek well SR4 and the existing iron and manganese wellhead treatment facility, and would require construction of a new water storage pump station and pipeline, new injection and extraction wells and a new WTP. The new water storage pump station would be located downstream of the iron and manganese treatment facility at the existing SR4 and produce enough pressure for extracted water to be pumped and injected into the Hard Rock Aquifer. The new Hard Rock Aquifer wells would be deep wells and have dual function including both injection and extraction. When extracted from the Hard Rock Aquifer wells, water would need to be treated by brackish water RO membranes to remove elevated salinity before being delivered to the Cambria water supply.

*Technical Feasibility Assessment* – All of the Hard Rock ASR concept facilities are common in the water supply industry, and their implementation would require standard construction methods and routine O&M practices. Low construction, O&M costs render this concept as highly cost efficient.

*Recommendation* - The Hard Rock ASR concept was recommended to be carried over in the Tier II Water Supply Concepts for further development and evaluation however feasibility of this concept depends on confirmation of the Hard Rock Aquifer storage capacity and land availability.

### 2.2.20 Water Supply Concept 20 - Wastewater from San Simeon Community Concept

*Description* – The Wastewater from San Simeon Recycled Water Concept would divert raw wastewater from the San Simeon community to Cambria for treatment at the CCSD’s WWTP. The diverted wastewater would be treated to tertiary effluent and used as non-potable recycled water, which in

return would offset demand for additional new potable water supplies for the Cambria community. The San Simeon Recycled Water Concept would consist of a new wastewater pump station, a new wastewater force main, upgrades of the existing CCSD's WWTP, and recycled water distribution main pipelines. The new wastewater pump station would be located at the existing San Simeon WWTP. The new wastewater force main would be laid along PCH in the Caltrans ROW, and convey the diverted wastewater from San Simeon to Cambria. The existing CCSD's WWTP would be upgraded for new tertiary treatment that would produce California Title 22 tertiary effluent for non-potable reuse. Potential users for the recycled water would be similar to those previously identified within the CCSD's 2003 recycled water distribution system master plan.

*Technical Feasibility Assessment* – The above described San Simeon Recycled Water Concept facilities are common in the wastewater and recycled water industry. Their construction requires standard construction means and methods, and their O&M are within common and well established practices. Construction and O&M costs of this concept are within the range of costs for similar recycled water projects in Southern California.

*Recommendation* - The San Simeon Recycled Water Concept was recommended to be carried over in Tier II Water Supply Concepts for further development and evaluation however to meet the flow requirements this concept was subsequently revised by supplementing wastewater flow from the San Simeon WWTP with wastewater from Cambria WWTP, see Section 3.2.3.

### 2.2.21 Water Supply Concept 21 – Tropospheric Water Precipitation Concept

The Tropospheric Water Precipitation Concept was identified and discussed during the March 15, 2012 EIS public Scoping Meeting. In general, the Tropospheric Water Precipitation would precipitate water moisture from the environmental air that would be collected and used for the water supply. Further research showed this technology may be used for some individual households, but would not be practical and cost efficient for large scale municipal use. The Tropospheric Water Precipitation Concept is therefore not recommended for further development and evaluation as a Tier II water supply concept.

### 2.2.22 Water Supply Concept 22 - Naisetra Offshore Seawater Desalination Concept

The Naisetra Offshore Seawater Desalination Concept (Naisetra Concept) was discussed during the March 15, 2012 EIS public Scoping Meeting. In general, the Naisetra Concept would utilize hydrostatic pressure of the ocean water to drive permeate through RO membranes. However, to make this happen, the RO membrane and permeate pumps need to be placed about 2,000 ft. below the ocean surface, which, in the case for Cambria, would require the installation to be located approximately 16 miles offshore. The pumping energy could conceivably be somewhat less than for an onshore/more accessible desalination facility with efficient energy recovery, however, the Niasetra system pumping would still need to overcome osmotic forces, losses through the desalination membranes, and transmission piping system losses.

The Naisetra Concept is not recommended for further development and evaluation as a Tier II water supply concept for the following reasons:

- The technology is still in development without known installations in the United States,
- It would require a long (15 mile) offshore pipeline, and

- The cost of O&M would be high and would require specialty equipment and tools which may not be available at the present time.

### 2.2.23 Water Supply Concept 23 - Air Force Radar Storm Sewer Outfall Reuse

An obsolete Air Force Radar facility storm Sewer Outfall pipeline was suggested as a possible use towards a seawater intake and/or concentrate return for a possible seawater desalination concept during the March 15, 2012 EIS scoping meeting. Additional search for the pipeline location, alignment, condition, and any associated easements did not result in information that would support the feasibility of this concept. A local hydrogeologist has reported seeing only rusted supports with no pipeline, which may be non-existent or in disrepair. Therefore the Radar Storm/Sewer Outfall pipe is not recommended to be further developed and evaluated as a Tier II water supply concept.

### 2.2.24 Water Supply Concept 24 - Small Scale Storage Ponds Concept

The small scale Storage Ponds Concept was identified and discussed during the March 15, 2012 EIS scoping meeting. The concept would utilize multiple small size stock ponds within the San Simeon (or Santa Rosa) Creek watersheds to retain water during wet weather season for its later use during the dry weather season. Initial evaluation of this concept showed that about 900 of approximately four ft. deep ponds would be required to provide a reliable water supply for the Cambria community. Construction of this large number of ponds would be costly, and their operation very complex. O&M of this huge number of ponds would be expensive and extremely labor intensive. Therefore, the Small Scale Storage Ponds Concept is not recommended for further development and evaluation as a Tier II water supply concept.

### 2.2.25 Water Supply Concept 25 - Off-Stream Canyon Storage Concept

*Description* – The Off-Stream Canyon Storage Concept would divert and store the raw water during wet seasons from the San Simeon Creek or Santa Rosa Creek for its use during the dry seasons. The stored water would be extracted from this storage and then treated and delivered to the Cambria community as a potable water supply. The Off-Stream Storage Concept would consist of water diversion wells, water diversion pipeline, off-stream canyon storage reservoir(s), a surface WTP, and product water pipeline. The water diversion wells would be shallow and large diameter located in the San Simeon Creek alluvial deposits and located as close as possible to the creek bed. The diverted water pipeline would convey the water from the creek to the storage facilities. Two options have been considered for the off-stream canyon storage, including;

- A manmade excavated and lined reservoir, and
- A reservoir that could be formed by a dam in one or more creek tributary streams.

The latter was assumed as more practical for construction and more cost efficient for this application. To provide a reliable water supply, the off-stream storage reservoirs would be sized for multi-year storage. The stored water would supply the proposed surface WTP and be laid along San Simeon Creek Road. The new surface WTP would be located on the CCSD owned land next to the existing percolation ponds and would treat the stored water to meet Cambria Community potable water needs during dry seasons. The product water pipeline would be laid out along the existing access road to the percolation ponds and would connect the proposed surface WTP with the existing CCSD potable water pipeline in San Simeon Creek Road.

*Technical Feasibility Assessment* – The Off-Stream Canyon Storage Concept would provide a reliable water supply source to the Cambria community. Construction of the storage reservoir(s) would be costly and require a challenging permitting and land acquisition process, but would employ standard construction means and methods. The CCSD would be chartered to operate and maintain dams and reservoirs, which would be a new challenge to the CCSD staff. Implementation of the other concept facilities discussed before would require standard construction methods and routine O&M.

*Recommendation* – Although costly and associated with some implementation challenges, and per direction received during a September 19, 2012 CCSD Board meeting, the Off-Stream Canyon Storage Concept is recommended to be carried over in Tier II Water Supply Concepts for further development and evaluation.

### 2.2.26 Water Supply Concept 26 - Water Conservation Concept

The Water Conservation Concept was identified and discussed during the March 15, 2012 EIS scoping meeting. Its subsequent evaluation showed that the Water Conservation Concept alone would not meet Cambria community water demands, and therefore it is not carried over in Tier II concepts for further development and evaluation. This concept is defined in a greater detail in the CCSD's Urban WMP, which is currently being implemented by the CCSD.

### 2.2.27 Water Supply Concept 27 - Gray Water Concept

The Gray Water Concept was identified and discussed during the March 15, 2012 EIS scoping meeting. Its subsequent evaluation showed that the Gray Water Concept alone would not meet Cambria community water demands, and therefore it is not carried over in Tier II concepts for further development and evaluation. This concept is also discussed within the CCSD's Urban WMP.

### 2.2.28 Water Supply Concept 28 - Capturing Rainwater Runoffs Concept

The Capturing Rainwater Runoff Concept was identified and discussed during the March 15, 2012 EIS scoping meeting. Its subsequent evaluation showed that the Capturing Rainwater Runoff Concept alone will not meet Cambria community water demands, and therefore it is not carried over in Tier II concepts for further development and evaluation. However, this concept is defined in greater detail as a means to reduce future outdoor water irrigation within the CCSD's 2003 Recycled Water Distribution System Master Plan.

## 2.3 Screening of Tier I concept and options

The twenty eight (28) Tier I identified and described water supply concepts were screened with an objective to select technically feasible and practically implementable concepts that have enough capacity to provide the Cambria community with emergency water supply. The screening criteria included:

- Capacity to provide emergency water supply,
- Technical feasibility, and
- Practical implementability.

*Capacity to provide emergency water supply* is an assessment of a concept to reliably provide a minimum 250 AF of water to the Cambria community during six dry season months per year, in a sustained manner during at least three consecutive dry years.

*Technical feasibility* assumes that: (1) there are not natural site specific conditions that would render a concept or an option not feasible for construction, (2) construction of concept or option facilities will employ readily available materials and technical skills, and (3) proposed concept and option is based on proven equipment and technology.

*Practical implementability* assumes: (1) reasonable time and effort to obtain all legal documents for construction, and (2) construction cost is within reasonably acceptable cost ranges for that specific concept facilities.

### 2.3.1 Screening Results

Each of the Tier I identified concepts and options was screened using the described screening criteria, and the screening results are summarized in Table 2.3.1-1. Eight of the twenty eight Tier I concepts and options met all screening criteria and were passed for further development and evaluation as is described in more detail in Section 3 of this TM.

- Water Supply Concept 1 - Shamel Park Option 4,
- Water Supply Concept 8 – City of Morro Bay Shared Desalination Facility,
- Water Supply Concept 11 – Estero Bay Marine Terminal Option 3,
- Water Supply Concept 14 – San Simeon Creek Road Brackish water Option 3,
- Water Supply Concept 18 – Whale Rock Reservoir Exchange without Lake Nacimiento Water Exchange,
- Water Supply Concept 19 – Hard Rock Aquifer Storage and Recovery,
- Water Supply Concept 20 – Waste Water from San Simeon Community, and
- Water Supply Concept 25 – Off-Stream Canyon Storage.

The other twenty (20) concepts and options did not pass the Tier I screening criteria and were dropped from further development and evaluation. Reasons for elimination are detailed in the columns "Reason for Elimination" and "Comment" of Table 2.3.1-1.

**Table 2.3.1-1 Screening Summary of Tier I Water Supply Concepts and Options**

No.	Concepts	Summary Description of Options and Concepts	Screening Criteria			Reason for elimination	Recommended for Tier II	Comments
			Provides Emergency Water Supply	Technically Feasible	Practical Implementability			
1	Shamel Park	<b>Option 1 - Water Supply Concept 1:</b> Three slant well seawater intake in Paleochannels A and B, and HDDW concentrate return.	Y	Y	Y	Option 4 meets objectives better.	No	Based on initial geotechnical investigation Paleochannels A and B are filled with low permeability deposits which increases complexity for water extraction.
2		<b>Option 2 - Water Supply Concept 2:</b> Open ocean engineered gallery for seawater intake, and HDDW concentrate return.	Y	Y	Y	Option 4 meets objectives better.	No	This concept will have negative impacts on the marine environment as well as on Shamel Beach utilization during construction activities. Implementation of this concept may not be environmentally and economically justifiable.
3		<b>Option 3 - Water Supply Concept 3:</b> Slant well seawater intake (300 ft from Santa Rosa Creel Preserve boundary), and HDDW concentrate return.	Y	Y	Y	Option 4 meets objectives better.	No	Although Option 3 is similar to Option 4, Option 4 with HDDW gives more flexibility to meet objectives better of intercepting Paleochannel C.
4		<b>Option 4 - Water Supply Concept 4:</b> HDDW seawater intake (600 ft from Santa Rosa Creel Preserve boundary), and HDDW concentrate return.	Y	Y	Y	No reasons for elimination. Meets all screening criteria.	Yes	Implementation of this concept is contingent upon confirmation of pale channel capacity to provide the targeted emergency water supply
5	Lampton Park	<b>Water Supply Concept 5:</b> HDD constructed open ocean seawater intake, and HDD constructed open ocean concentrate return.	Y	Y	N	Access through geologically sensitive area. Requires HDD or micro-tunneling of a 2500' long tunnel through hard volcanic rocks.	No	Implementation of this concept may not be environmentally and economically justifiable.
6	San Simeon Seawater	<b>Option 1 - Water Supply Concept 6:</b> HDDW seawater intake in fractured shells at Old San Simeon Village, and Horizontal Well at CCSD owned Flag Lot for concentrate return.	Y	Y	N	Difficult for implementation because San Simeon Village is too sensitive for HDDW.	No	Geotechnical investigation for well seawater intake one mile northwest of the Old San Simeon Village did not have hydraulic conductivity to support the targeted capacity for emergency water supply.
7		<b>Option 2 - Water Supply Concept 7:</b> HDDW seawater intake in fractured shells at Old San Simeon Village, and open ocean outfall at San Simon CSD's WWTP for concentrate return.	Y	Y	N	Difficult for implementation because San Simeon Village is too sensitive for HDDW.	No	Geotechnical investigation for well seawater intake one mile northwest of the Old San Simeon Village did not have hydraulic conductivity to support the targeted capacity for emergency water supply. Open ocean outfall for concentrate return would add additional complexity for this alternative application.
8	City of Morro Bay Shared Desal Facilities	<b>Water Supply Concept 8:</b> Morro Bay beach wells seawater intake, and concentrate return via power plant cooling water return canal.	Y	Y	Y	Meets all screening criteria.	Yes	Implementation of this concept requires negotiation and coordination with City of Morro Bay.
9	Estero Bay Marine Terminal	<b>Option 1 - Water Supply Concept 9:</b> Seawater intake at City of Morro Bay beach well field and concentrate return into existing power plant cooling water return canal.	Y	N	Y	No reliable information about existence of the Chevron's Marine Terminal Outfall.	No	The power plant's once-through cooling system may change in the future, which could complicate concentrate return approach.
10		<b>Option 2 - Water Supply Concept 10:</b> Retrofit existing Oil Tanker Loading Pipeline to open ocean seawater intake, and concentrate return via Morro Bay power plant cooling water return canal.	Y	N	Y	No reliable information about existence of the existing Oil Tanker Loading Pipeline	No	It is most likely that the existing Oil Tanker Loading Pipeline is not in repairable conditions. Also, Chevron is under court order to demolish this abandoned Oil Tanker Loading Pipeline.
11		<b>Option 3 - Water Supply Concept 11:</b> HDDW in Toro Creek paleochannel for subterranean seawater intake, and concentrate return via Morro Bay power plant cooling water return canal.	Y	Y	Y	Meets all screening criteria.	Yes	Feasibility of this alternative is contingent upon confirmation of location and hydro-geological capacity of Toro Creek paleochannel to provide targeted flow for emergency water supply.

**Table 2.3.1-1 Screening Summary of Tier I Water Supply Concepts and Options**

No.	Concepts	Summary Description of Options and Concepts	Screening Criteria			Reason for elimination	Recommended for Tier II	Comments
			Provides Emergency Water Supply	Technically Feasible	Practical Implementability			
12	San Simeon Creek Road Brackish Water	<b>Option 1 - Water Supply Concept 12:</b> Direct potable use of the AWTP treated brackish water. Subterranean ocean concentrate return via existing horizontal well at CCSD owned Flag Lot.	Y	Y	Y	Option 3 meets objectives better.	No	There are concerns of direct potable use of the treated brackish water extracted from the basin by extraction wells located close to the secondary effluent percolation ponds.
13		<b>Option 2 - Water Supply Concept 13:</b> AWTP treated brackish water recharge in the San Simeon Creek basin at CCSD potable water well-field. Open ocean concentrate return via existing ocean outfall at the San Simeon CSD WWTP.	Y	Y	Y	Option 3 meets objectives better.	No	Use of the existing ocean outfall at the CCSD's WWTP would require coordination and an agreement with San Simeon CSD and complex permitting process for concentrate disposal.
14		<b>Option 3 - Water Supply Concept 14 :</b> AWTP treated brackish water recharge in the San Simeon Creek basin at CCSD potable water well-field. Concentrate return by injection in deep aquifer high salinity water -seawater wedge.	Y	Y	Y	Meets all screening criteria.	Yes	Hydro-geological modeling is required to locate and design the project facilities.
15	Lake Nacimiento Pipeline	<b>Option 1 - Water Supply Concept 15:</b> Water from Lake Nacimiento would be pumped across Santa Lucia Mountains and discharged in the San Simeon Creek watershed to increase basin water capacity at CCSD's potable water well field during dry season.	Y	Y	N	Not practical nor cost efficient for implementation.	No	Pipeline route over mountains is too risky. Very difficult access complicates construction activities. Long piping alignments has high probability for negative impact on possible environmentally sensitive areas. May not be practical and justifiable for CCSD as a sole user of the system.
16		<b>Option 1 - Water Supply Concept 16:</b> Water from Lake Nacimiento would be pumped across Santa Lucia Mountains and discharged in the San Simeon Creek to increase basin water capacity at CCSD's potable water well field during dry season.	Y	Y	N	Not practical nor cost efficient for implementation.	No	Pipeline route over mountains, too risky. Very difficult access complicates construction activities. Long piping alignments has high probability for negative impact on possible environmentally sensitive areas. May not be practical and justifiable for CCSD as a sole user of the system.
17	Whale Rock Reservoir with Lake Nacimiento Water Exchange	<b>Water Supply Concept 17:</b> CCSD would use water from Whale Rock Reservoir in exchange with City of San Luis Obispo for their use of the CCSD's water entitlement in the Lake Nacimiento.	Y	Y	N	Difficult for implementation, and costly for operation and maintenance.	No	Implementation of this concept would require extensive negotiations and agreement with multiple stake holders including City and County of SLO and Department of Water Resources. Complex and costly operation and maintenance.
18	Whale Rock Reservoir Exchange without Lake Nacimiento Water Exchange	<b>Water Supply Concept 18:</b> CCSD would store excess water from Santa Rosa Creek and San Simeon Creek in the Whale Rock Reservoir during wet weather season for its use during dry season.	Y	Y	Y	No reasons for elimination. Meets all screening criteria.	Yes	Implementation of this concept is contingent on agreement with City and County of SLO.
19	Hard Rock Aquifer Storage and Recovery	<b>Water Supply Concept 19:</b> Excess water from Santa Rosa basin is extracted and pumped for storage in Hard Rock aquifer for use during dry weather season.	Y	Y	Y	Meets all screening criteria.	Yes	Feasibility of this concept depends on confirmation of the Hard Rock Aquifer storage capacity and agreement with land owner for land use for CCSD water supply project.
20	Wastewater form San Simeon Community	<b>Water Supply Concept 20:</b> CCSD would divert wastewater form San Simeon community for treatment at CCSD's WWTP. Tertiary effluent would be used for irrigation to offset potable water demand.	N	Y	Y	This concept does not provide flow to meet Cambria emergency water demand.	Yes	If economically feasible, this concept could be used as a supplemental water supply with some other concept(s).
21	Tropospheric Water Precipitation	<b>Water Supply Concept 21:</b> Moisture from environmental air would be condensed and the condensate collected for domestic use.	N	N	N	Not practical for public water supply systems	No	This technology is intended for individual home use. It is unpractical for public water supply.
22	Niasetra off-shore desalination RO	<b>Water Supply Concept 22:</b> Seawater RO membrane submerged in a pipe 2,000 ft below ocean surface. No concentrate return required.	Y	N	N	Technology in development - not yet commercially available	No	High risk to maintain equipment in 2,000' depth ocean 16 miles offshore. Would require off shore O&M equipment and specialty staff. Is not proven technology and may not be economically justifiable for CCSD's water supply.



**Table 2.3.1-1 Screening Summary of Tier I Water Supply Concepts and Options**

No.	Concepts	Summary Description of Options and Concepts	Screening Criteria			Reason for elimination	Recommended for Tier II	Comments
			Provides Emergency Water Supply	Technically Feasible	Practical Implementability			
23	<b>Air Force Radar storm/sewer outfall pipe</b>	<b>Water Supply Concept 23:</b> Assumes use of an obsolete Air Force Radar storm water ocean outfall for either seawater intake or concentrate return.	NK	NK	N	No information of the Air Force Radar storm water ocean outfall was found	No	Pipe is reported by hydro geologist as missing.
24	<b>In-stream Small Scale Storage Ponds</b>	<b>Water Supply Concept 24:</b> Multiple small ponds would be installed in the live stream of the San Simon Creek or Santa Rosa Creek that will retain water during wet seasons for use during dry season.	Y	Y	N	Economically not efficient and technically not practical for implementation	No	Excessive number (in hundreds) of small ponds would be required in live stream of the San Simeon Creek or Santa Rosa Creek.
25	<b>Off-stream Canyon Storage</b>	<b>Water Supply Concept 25:</b> Water from either San Simeon Creek or Santa Rosa Creek would be diverted for off stream storage during wet season for use during dry weather season.	Y	Y	Y	Although high cost and difficult to permit, this concept is recommended for Tier II evaluation.	Yes	Hilly geography of the off stream canyons with steep slopes would require costly and more difficult to implement dam(s).
26	<b>Enhanced Water Conservation</b>	<b>Water Supply Concept 26:</b> Enhanced conservation by reduced per capita water use.	N	Y	Y	Does not meet water demand as a stand alone concept.	No	Cambria community is already at low per capita use. Further reduction will not reach capacity for emergency supply.
27	<b>Gray Water</b>	<b>Water Supply Concept 27:</b> Reclaimed water wasted from laundry would be used for toilets and other non-potable/non-body contact use.	N	Y	N	Does not meet capacity for emergency supply.	No	This concept is applicable for individual households, not for public water supply systems.
28	<b>Capturing Rainwater Runoff Water</b>	<b>Water Supply Concept 28:</b> Multiple ponds, natural depressions and/or cisterns would be installed to capture urban rainwater run off during the wet season for later use during dry season.	Y	Y	N	Not practical nor cost efficient for implementation.	No	Large number of ponds or cisterns would be required. Shallow ponds have large losses in evaporation.

Y=yes; N- no; NK - not known



## Section 3

# Tier II Water Supply Alternative Concepts

### 3.1 Concept Development Approach

The eight water supply options selected through the Tier I screening criteria (the Tier II water supply concepts) are named in this section as alternative water supply concepts, alternative concepts, or sometimes simply as concepts. The Tier II alternative water supply concepts have been developed with sufficient details to include key technical features of their major facilities. These details provide the basis to develop planning level construction and O&M costs. Based on these costs, a life cycle cost analysis were prepared for each of the eight Tier II alternative concepts, including the uniform equivalent annual cost (UEAC), which was used to estimate the cost of one AF of the product water.

#### *Base Engineering Data and Inputs*

Multiple sources of information have been used in developing the Tier II alternative water supply concept details. Publicly available USGS maps and Google Earth maps have been used to develop the overall facility layouts and estimate distances and elevation for the concept facilities. Field surveillance and the Geotechnical Study Report – Cambria Water Supply, SLO County, California prepared by Diaz Yourman Associates (DYA), July 27, 2012, provide geotechnical and hydro-geotechnical inputs and criteria to size and engineer the Tier II alternative concept facilities. Readily available legal and technical documents, site visits, interviews, and conference calls with local personnel at San Simeon WWTP, Cambria WWTP, Cayucos WTP and Morro Bay SWRO plant provided important information on the existing facilities. Finally, and most importantly, CCSD engineering and O&M staff provided invaluable guidance and input into the development of the engineering details of the Tier II alternative water supply concepts.

#### *CCSD and Cambria Community Involvement*

The Board held four public workshops from June 2012 to September 2012 to facilitate the presentation of the alternative water supply concepts to the Cambria community residents. The workshops were broadcast using an interactive WebNet, which allowed participation and input from other critical stake holders, such as the CCC, State Parks, State Department of Fish and Game, and City of Morro Bay. Key inputs and major decisions, such as identification and capacity of alternative water supply concepts and importance and weights of the evaluation criteria, were received from the Cambria community residents and other stake holders during these four workshops.

### 3.2 Concept Descriptions

The following sections provide a detailed description for each of the eight (8) Tier II water supply alternative concepts. As evaluation of the Tier I concepts and options described in the previous Section 2 of this TM advanced, names of the selected Tier II concepts changed. In the following list, the names of the concepts as they are used in Section 2 of this TM are bracketed and typed in italics.

- Shamel Park Seawater (Water Supply Concept 4 - *Shamel Park Option 4*),
- Morro Bay Shared SWRO (Water Supply Concept 8 - *City of Morro Bay Shared Desalination Facility*),
- Estero Bay Marine Terminal (Water Supply Concept 11 - *Estero Bay Marine Terminal Option 3*),

- San Simeon Creek Road Brackish Water (Water Supply Concept 14 - *San Simeon Creek Road Brackish Water Option 3*),
- Whale Rock Reservoir (Water Supply Concept 18 - *Whale Rock Reservoir Exchange without Lake Nacimiento Exchange Water*),
- Hard Rock ASR (Water Supply Concept 19 - *Hard Rock Water Storage and Recovery*),
- San Simeon CSD Recycled Water (Water Supply Concept 20 - *Wastewater from San Simeon Community Concepts*), and.
- San Simeon Creek Off -Stream Storage (Water Supply Concept 25 - *Off-stream Canyon Storage Concept*).

### 3.2.1 Alternative Concept 1 Shamel Park Seawater

#### 3.2.1.1 Alternative Description

Shamel Park seawater supply concept includes the following components:

- A subterranean HDD well seawater intake with the entry point located at the parking lot east of Shamel Park and the intake well screen installed within Paleochannel C,
- A Seawater pipeline along Windsor Boulevard,
- A SWRO located on the CCSD owned property immediately west of the existing WWTP,
- A product water pipeline that connects the SWRO facility with the CCSD water distribution system,
- A concentrate return pipeline, and
- A subterranean HDD well concentrate return with the entry point located at the parking lot east of Shamel Park and extending to Paleochannel C.

Shamel Park is about 0.2 mile west of the existing Cambria WWTP, where the proposed SWRO desalination facility is located. As shown in Figure 3.2.1-1, the seawater feed and concentrate return are proposed to be conveyed by pipelines from the proposed SWRO site to Shamel Park along Windsor Boulevard. The subterranean seawater intake and concentrate return are constructed from the entry points at the parking lot east of the Park and extend to Paleochannel C without crossing the boundary of Santa Rosa Creek Natural Preserve (SRCNP).

This alternative concept would provide a reliable supply of high quality drinking water to the Cambria community during summer dry seasons. The production capacity of SWRO is assumed to be 250 AF over a period of six (6) months. This is equivalent to a daily production capacity of 0.44 million gallons per day (MGD), or 307 gpm. The facility components would be designed to allow operation at two incremental capacities of 0.22 MGD or 0.44 MGD.

The SLO County owned Shamel Park is located near the beach outside of the south boundary of SRCNP. The park is south of the Santa Rosa Creek Beach (or Moonstone Beach), which is part of San Simeon State Park. This area of the California coastline is within the MBNMS. Using the County owned Shamel Park as the seawater intake and concentrate return's entry points and construction sites simplifies the permitting process.

The SWRO feed water is extracted from the permeable sediments in Paleochannel C through an HDD well drilled from Shamel Park. The SWRO concentrate return is discharged to the permeable sediments in Paleochannel C further offshore, approximately 1,500 ft. away from the intake.

The technical feasibility of this alternative is subject to further confirmation of the existence and permeability of Paleochannel C. Detailed geotechnical and geophysical investigations are needed to gather hydrogeologic data to investigate potential environmental impacts and support the design of the proposed subterranean seawater intake. The CCC denied the Coastal Consistency Determination prepared for the proposed investigations of Paleochannel C at Santa Rosa Creek Beach and Shamel Park beach areas. As a result, the proposed investigations are not being conducted at this time.



**Figure 3.2.1-1**  
 Alternative Concept 1  
 Shamel Park Seawater Overall System Layout

## Cambria Water Supply Technical Memorandum



The following sections of this document present key elements of the Shamel Park Seawater alternative. The detailed information have been reported in TM 4.1.4A Seawater Treatment Plant Alternatives, TM 4.1.1A Seawater Intake Alternatives, and TM 4.1.9A Concentrate Return Alternatives.

### 3.2.1.2 Flows and Water Mass Balance

The production capacity of this alternative is 250 AF over a period of 184 days during the dry season.

Due to the nature of how RO systems operate, an RO treatment unit typically has a relatively fixed production capacity. Therefore, the production rates of the facility will be primarily determined by the number of RO units included in the design. For the purpose of this TM, it is assumed that the facility will include two (2) equally sized 0.22 MGD RO units and will operate at production capacities of 0.22 and 0.44 MGD. For the purpose of developing cost and energy estimates, this TM assumes that the annual average production capacity from the facility will be 0.44 MGD.

It is assumed that the RO system will operate at 40 percent recovery. Table 3.2.1-1 summarizes the source water (feed flow from intake), product water flow (RO permeate), and waste stream water flow (RO concentrate for discharge).

**Table 3.2.1-1 Flow Rates**

Description	Units	Full Capacity – 0.44 MGD Production
RO System Recovery	%	40%
Feed Flow From Intake	MGD	1.1
RO Permeate	MGD	0.44
RO Concentrate for Discharge	MGD	0.66

#### *Source Water*

The source water for the Shamel Park SWRO Alternative is seawater from a subterranean intake structure installed in Paleochannel C. The source water flows would range from 0.55 MGD to 1.1 MGD, which is equivalent to 310 AF to 621 AF during the six (6) months of dry season.

#### *Product Water Flow*

The product water flow from the Shamel Park HDD well Alternative WTP is 250 AF during six (6) months of dry season.

#### *Concentrate Return Flow*

The volumes and flow rates of the brine generated by RO vary depending on the hydraulic recovery rate. In this TM, assuming a 40 percent hydraulic recovery, the daily concentrate return flow ranges from 0.33 MGD to 0.66 MGD. The concentrate is assumed to be returned into the ocean through a subterranean concentrate return well installed in Paleochannel C.

### 3.2.1.3 Water Quality

Source water quality determines the selection and design of the pretreatment system, while product water quality goals determine the selection and design of the RO desalination and post treatment systems. The source water quality assumptions and the preliminary product water quality goals for this alternative are provided in the following sections.

### Source Water

The source water of the SWRO plant is from the proposed subterranean intake installed in the permeable sediments in Paleochannel C. Based on the similar projects with source water extracted from the subterranean seawater intakes in the Pacific Coast area, the assumed water quality data for the source water are summarized in Table 3.2.1-2.

**Table 3.2.1-2 Assumed Source Water Quality**

Description	Units	Assumed Source Water Quality
TDS	mg/L	35,000 (34,000 to 36,000)
pH	pH Unit	8.0 (7.9 to 8.1)
Turbidity	NTU	<0.2 (0.1 to 1)
TOC	mg/L	<1.0 (0.5 to 1.0)
Hardness	mg/L as CaCO <sub>3</sub>	>120
Silt Density Index (SDI)	SDI15 Unit	<3
Chloride	mg/L	19,000 (18,000 to 20,000)
Bromide	mg/L	65
Boron	mg/L	4.5 (4.0 to 5.0)
Iron	mg/L	Unknown
Manganese	mg/L	Unknown

It is currently unknown if iron and/or manganese will be present at concentrations of greater than 0.05 mg/L from a subterranean HDD well. According to CCSD, iron and manganese have been detected at the closest onshore well, suggesting that there is a reasonable likelihood that they would be present in the HDD well water.

### Product Water

The product water quality goals are summarized in Table 3.2.1-3. The parameters that impact selection and design of the RO desalination system are identified in bold text. The parameters that impact selection and design of the post-treatment system are identified in italic text.

**Table 3.2.1-3 Product Water Quality Goals**

Description	Units	Proposed Goals	Regulatory Limit
<b>TDS</b>	mg/L	<250 from RO; <330 after post-treatment	≤500
<b>Chloride</b>	mg/L	<140 <sup>1</sup>	≤250
<b>Boron</b>	mg/L	<1.0 <sup>1</sup>	≤1.44
<b>Bromide</b> (if applicable for DBP control)	mg/L	<0.5	TTHM: <0.080 HAA5: <0.060
<i>Hardness</i>	mg/L as CaCO <sub>3</sub>	40-50	n/a
<i>Alkalinity</i>	mg/L as CaCO <sub>3</sub>	40-60	n/a
<i>pH</i>	pH Unit	Match pH in distribution system (assumed to be approximately 8.0; confirm with CCSD)	6.5-8.5
Free Chlorine Residual	mg/L	Match residual in distribution system (assumed to be approximately 1.0)	<4.0
<i>Langlier Saturation Index</i>	LSI Unit	> - 0.5 or add corrosion inhibitor	Non-corrosive

Notes:

1) These values are the recommended limits for water used to irrigate the majority of ornamental and garden plants in California.



### 3.2.1.4 Description of System Facilities

The Shamel Park alternative consists of four key new facilities including subterranean seawater intake, SWRO treatment plant, ocean subterranean concentrate return, and the facility interconnecting pipelines. In the following section, each facility is discussed in more detail.

#### *System Design Criteria*

The design criteria for each of the major new facilities, including intake, treatment plant and product water conveyance, as well as concentrate return, are provided in the following Table 3.2.1-4. Description of each of the system components is provided in the subsequent sections.

**Table 3.2.1-4 Design Criteria**

Facility	Unit	Criteria
<b>Seawater Intake</b>		
Seawater intake	Type	HDD Well
Number of HDD wells	#	1
HDD well diameter	inch	12
HDD well length	ft	1,200
Well screen length	ft	200
Well Production	gpm	768
Well Production	gpd	1,105,200
HDD well pump TDH	ft	94
Pump horsepower	HP	25
<b>Seawater Pipeline</b>		
Pipe flow rate	cfs	1.71
Velocity	fps	4
Pipe diameter	inch	10
Pipe length	ft	1,608
Pipe material		PVC/HDPE
<b>Seawater Treatment Plant</b>		
Plant product water capacity	gpm	307
	gpd	442,080
<b>SWRO Treatment Plant</b>		
Type		1 micron cartridge filter
Number of cartage filters		2
Capacity per cartridge filter	gpm	230
pH adjustment		NaOH/H2SO4
Antiscalant		TI
Number of SWRO Skids	#	2
Capacity per skid/RO permeate	gpm	154
SWRO Skid configuration		Single pass/two stage
Membrane elements	Size/type	8 inch SWRO membrane
Recovery	%	40
Flux	gfd	8 to 10
Primary RO feed pumps	# and Type	2, Positive displacement
Primary Feed Pump capacity	gpm	154

**Table 3.2.1-4 Design Criteria**

Facility	Unit	Criteria
TDH	psi	1000
Drive	Type	VFD
Horse power per pump	HP	120
Energy Recovery Device	Type	Pressure exchange (PX) or work exchange
Efficiency	%	95%
RO Booster Pump Capacity	gpm	230
Horsepower per pump	HP	10
pH and alkalinity adjustment		CO <sub>2</sub>
Remineralization		CaCO <sub>3</sub> Contactor
Primary disinfectant		UV Light
Virus inactivation and residual		NaOCl
<b>Concentrate return</b>		
Concentrate flow rate	gpd	663,120
Capacity	gpm	461
TDH	ft	49
Drive	Type	Constant speed
Horse power	HP	18
Number of pump	#	2
Pump	Type	Vertical turbine
Pipe flow velocity	fps	4
Pipe diameter	inch	8
Pipe length	ft	1,584
Pipe material		PVC
Concentrate return well	Type	HDD well
Number of HDD wells	#	1
HDD well diameter	inch	10
HDD well length	ft	2,250
Well screen length	ft	300
Well capacity	gpm	462
Well capacity	gpd	665,000
<b>Product Water Pump Station</b>		
Capacity	gpm	307
TDH	ft	209
Drive	Type	Constant speed
Horse power		52
Number of pumps	#	2
Pump	Type	Horizontal split case
<b>Product Water Pipeline</b>		
Pipe flow rate	gpm	307
Velocity	fps	4
Pipe diameter	inch	6
Pipe length	ft	1,072
Pipe material		PVC

### *Seawater Intake*

The source water intake would be provided by the proposed subterranean 10 inch diameter HDD well installed in Paleochannel C. From the entry point at the parking lot east of Shamel Park, a 1,200ft shallow HDD well is drilled with a 200ft long intake well screen located within Paleochannel C alluvium. The capacity of the intake structure is designed as 767.5 gpm (1.1 MGD). The proposed alignment of the HDD seawater intake structure is outside of the boundaries of the Santa Rosa Creek Natural Preserve.

### *Seawater Transmission*

The source water is conveyed through a 10 inch diameter and approximately 0.3 mile long pipeline along Windsor Boulevard from Shamel Park to the proposed SWRO plant. The pipeline route is outside of the south boundary of the Santa Rosa Creek Natural Preserve.

### *Water Treatment*

Pretreatment refers to a process upstream of the desalination system, which filters and conditions the water to prevent rapid clogging and fouling of the RO membranes in the desalination process. In addition to complying with regulatory requirements and RO membrane warranties, the following typical pretreatment water quality goals should be reached by the pretreatment facilities:

- A turbidity of 0.1 NTU or less.
- A total organic carbon (TOC) concentration of 2.0 mg/L or less.
- A silt density index (SDI) goal of 4.0 SDI15 units or less.
- Iron and manganese concentrations 0.05 mg/L or less.

In general, Pacific Ocean water is a good quality and is easy to pre-treat and desalinate. The source water quality of the subterranean intake is usually low in turbidity, SDI, and TOC compared to those associated with open ocean intakes. Most of the remaining foulants, such as sand, silt, and potentially scaling minerals, are expected to be either removed by the cartridge filters or sequestered by the antiscalant chemical before desalination. The exception to this would be iron and manganese, which, if present in their oxidized form in the RO feed, can cause extensive problems with plugging of the cartridge filters and RO membranes. For the Cambria facility, it was assumed that the source seawater will not have iron and/or manganese, however, if future testing demonstrates high iron or manganese content in the aquifer, it will be necessary to revise the design approach, either by eliminating raw water flow equalization to prevent iron oxidation, or providing oxidation and filtration for removal of iron and/or manganese prior to desalination.

Figure 3.2.1-2 presents a process schematic of the pretreatment process and subsequent RO desalination processes.

Positive displacement pumps are recommended for the Shamel Park SWRO plant because of their low energy (LE) use and stable operation during potential seasonal variations in source water salinity. Two high efficiency pumps and motors each with capacity of 153.5 gpm are assumed for this project, with the remainder of the feed water flow pumped by the energy recovery devices (ERD's) and booster pumps.

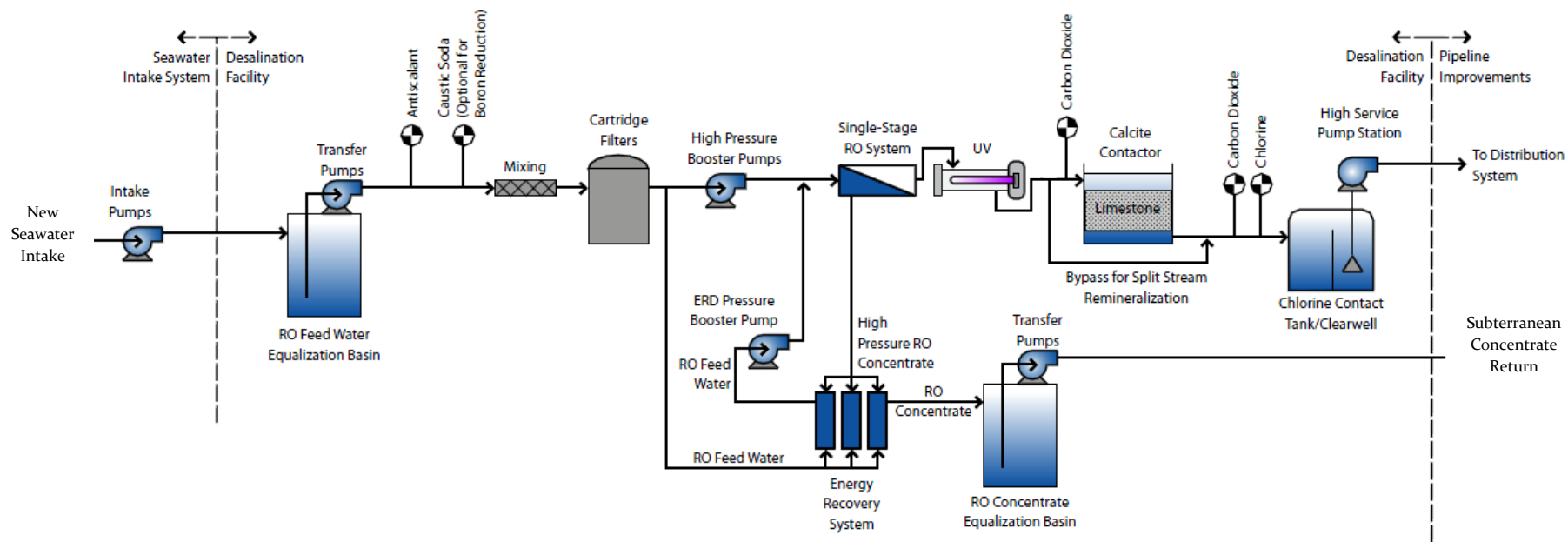

Figure 3.2.1-2 SWRO Plant Treatment Process Schematic

The new SWRO treatment plant is sized for product water capacity of 307 gpm and would run for six months during the dry summer season. The desalination process utilizes a single-stage single-pass configuration for the SWRO membranes that typically has the lowest equipment cost and energy use. For this project the single-stage RO system with operating recovery of 40 percent is assumed. This TM assumes two (2) RO membrane units each with a capacity of 0.22 MGD (153.5 gpm).

Each RO unit would consist of twelve (12) pressure vessels, each furnished with seven (7) LE eight (8) inch diameter RO membrane elements (e.g., SWC5) to optimize the balance between boron removal and power consumption. Each membrane unit will be configured to accommodate the installation of additional 2 vessels. ERD's are machines designed to recover and reuse the stored hydraulic energy in the RO concentrate stream. An isobaric ERD, such as an ERI PX or DWEER Work Exchanger is assumed for the RO process. The ERD's recover 95 to 98 percent of the energy from the concentrate and serve as the primary pressure boost for 60 percent of the feed water flow. To account for the small inefficiencies in the devices and the pressure losses within the SWRO system, two low head centrifugal booster pumps will be used in conjunction with the devices. The pumps will be driven by variable frequency drives (VFD) and are assumed to pump 230 gpm each.

Due to the relatively small size of this facility, it is recommended that the two RO units be installed as a single RO skid and configured as independent membrane units with a dedicated HP RO pump and energy recovery system for each membrane unit.

RO permeate is corrosive and requires stabilization and remineralization before it is pumped into the distribution system. The assumed post-treatment process includes a carbon dioxide (CO<sub>2</sub>) injection system, calcite contactors, and caustic soda to adjust pH and create bicarbonate alkalinity as well as calcium hardness. The CO<sub>2</sub> calculated uses rate is 75 lbs/day. The RO permeate passes through the calcite bed in the calcite reactors and forms calcium bicarbonate [Ca(HCO<sub>3</sub>)<sub>2</sub>]. The empty bed contact time is designed for 10 to 15 minutes. The advantage of calcite contactors is that no over dosage of the chemical can occur and the facilities require very low maintenance compared with lime feed systems.

The proposed disinfection system includes ultraviolet light (UV) disinfection to provide additional disinfection of Cryptosporidium and Giardia, and sodium hypochlorite (NaOCl) disinfection to provide additional virus disinfection as well as a disinfectant residual in the distribution system.

### *Waste Stream System*

The RO concentrate flow is returned to the ocean through a conveyance pipeline and HDD well to the permeable sediments in Paleochannel C. The concentrate pipeline would be eight (8) inches in diameter and would be laid out along Windsor Boulevard. The assumed HDD well subterranean concentrate return structure is a 10 inch diameter and 2,250 ft. long HDD well that ends up with a 300 ft. long screen.

### *Product Water Transmission and Connection to CCSD Distribution System*

The product water would be pumped from the clear well to the CCSD's existing potable water distribution system. The length of the product water transmission pipeline is approximately 0.2 miles. The pipeline is proposed to be constructed along Windsor Boulevard east of the SRCNP boundary. The six (6) inch product water transmission pipeline would connect to the existing 12 inches pipe of the CCSD's distribution system at the intersection of Moonstone Beach Drive and Windsor Boulevard.

### 3.2.1.5 Permitting Requirements

Implementation of this alternative would require permits from multiple permitting institutions including, but not limited to:

- **CCC** - permitting would be required for consistency with coastal development plan since the entire project is within the Coastal Zone boundary.
- **Regional Water Quality Control Board (RWQCB)** - to address the potential impact of subterranean intake on the Santa Rosa Creek basin and the discharge of brine below the ocean.
- **California Department of Health (CDPH)** - to address source water and product water quality requirements and to approve the proposed water treatment processes.
- **State Park** – the subterranean offshore facilities are within the boundary of Cambria Marine State Park.
- **Building Permits** – Grading and building permits may be required for the SWRO treatment plant.
- **SLO County** – construction permits may be required for HDD well intake and concentrate return drilling at the County owned Shamel Park.

### 3.2.1.6 System Construction Requirements

The construction of HDD wells utilizes “open hole” technology, which means that drilling fluid is required to hold the borehole open during drilling and construction. Drill pipe and downhole tools are used to advance the borehole, while drilling fluid is used to cool and lubricate the bit, stabilize the borehole, and carry cuttings (formation material) to the surface. Drilling of the borehole is generally achieved in two stages: drilling the small diameter pilot borehole, followed by enlarging the pilot borehole in one or more reaming passes to the diameter required to contain the casing, screen, and filter pack. Once the total lineal length and depth is reached, the pilot borehole is reamed by pushing and rotating the drill bit as it follows the pilot bore to its completion depth.

#### *Staging Location and Area*

All staging areas of the proposed SWRO plant would be on the CCSD owned land next to the CCSD’s WWTP. The site plan of a SWRO treatment plant of 150 ft. by 200 ft. is shown in Figure 3.2.1-3. The staging locations for equipment, materials and construction worker parking would be on flat areas around the treatment plant process building, including future parking, landscaped and open areas.

For the HDD well intake and concentration return facility construction, the staging locations and drilling entry points are located in the southern portion of the County owned Shamel Park and parking lot east of the park. For the intake construction, a footprint of 115 ft. wide by 130 ft. long is required assuming a drilling angle of 9.5° below horizontal, and an elevation of approximately ten (10) ft. above ground for the lower drive of the drilling rig.

#### *Construction Accessibility*

Construction access for the SWRO treatment plant would be from Windsor Boulevard off the PCH. Access to the proposed treatment plant site would be required for grading equipment, water trucks, cranes, equipment transportation trucks, and construction laborers. Adequate on-site parking during construction would be provided.

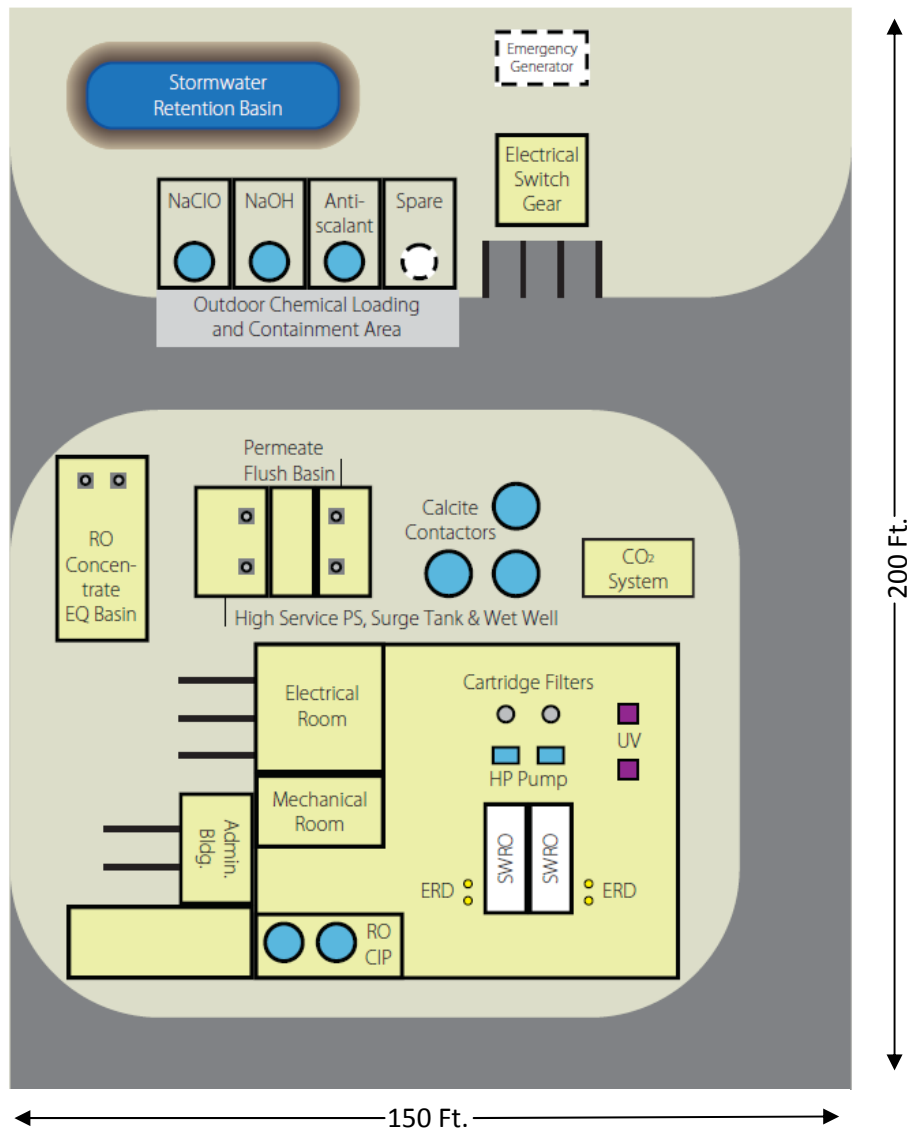

**Figure 3.2.1-3 Shamel Park SWRO Facility Layout**

Construction access for the drilling location at Shamel Park would be from the adjacent paved roadways (i.e., Windsor Blvd and US-1). The drilling work area and parking lot staging area would be surrounded by a six ft. high chain link fence. A portion of the parking lot where drilling activities would take place would be closed to public during the construction process. Use of nearby areas of the park would not be restricted during construction. The parking lot staging area would have a dimension of approximately 80 ft. by 150 ft.

#### *Special Material and Equipment Requirements*

For the treatment plant, RO and UV elements are proprietary and would need to be pre-purchased. Other equipment is readily available and will be part of the general contractor's scope of supply. Operation of the SWRO treatment plant would require transport and handling of chemicals at the plant site, including sodium hypochlorite, sodium hydroxide, antiscalant, carbon dioxide, and various cleaning solutions.

The HDD intake well screen would use 5/16-inch thick super duplex 2507 stainless steel materials with horizontal louvered openings. This stainless steel alloy will provide excellent corrosion resistance and prevent failure over the 50-year life of the project.

The treatment plant construction equipment would consist of standard commercial construction equipment, including earth moving equipment, scrapers, graders, dozers, back hoes, vibrating compactors, loaders, cranes, , forklifts, utility trucks, concrete trucks, and trailer mounted generators .

The HDD well construction equipment would consist of drilling equipment, gyroscopic steering device, temporary tanks, pumps, cranes, utility trucks, trailers and mounted generator.

Pipeline construction equipment would consist of standard pipeline construction equipment, including backhoes, vibrating compactors, loaders, cranes, utility trucks, and trailer mounted generators.

**Construction Duration**

The proposed SWRO treatment plant, subterranean seawater intake and concentrate return, and pipelines can be bid and constructed as a single project or separate projects due to the different types of contractors required. For a project of this size and magnitude, approximately a 16 to 20 month construction period is required assuming a typical five day per week schedule. Daily hours for construction activities would be limited by the County of SLO construction permits, However, it is expected to be between 7:00 am and 4:00 pm. Construction of the different facilities can be concurrent. Construction must be completed on all facilities by the start of treatment plant testing.

**3.2.1.7 Engineering Cost Estimates**

A planning level engineering cost estimate including capital and operating costs are prepared and summarized as follows. Detailed cost estimating backup information is provided in Appendix A.

**Construction Cost**

A summary of the estimate probable construction costs is shown in Table 3.2.1-5. Construction Contingency of 30 percent has been provided. An allowance of 25 percent of the construction cost is added for surveying, geotechnical investigation, engineering design, construction management, permitting and legal fees, and CCSD administrative and staff expenses.

**Table 3.2.1-5 Conceptual Estimate of Probable Construction Costs**

Facility		Total \$
Subterranean Seawater Intake		2,952,000
Seawater Pipeline		241,000
SWRO Treatment Plant		4,708,000
Subterranean Concentrate Return		2,491,000
Product Water Transmission		649,000
Subtotal		11,041,000
	Contingency (30%)	3,312,000
<b>Total Construction Cost</b>		<b>14,353,000</b>
	Project Implementation Cost (25%)	3,588,000
<b>Total Capital Cost</b>		<b>17,941,000</b>



### O&M Cost

The conceptual O&M costs for the Shamel Park subterranean HDD well alternative are shown in Table 3.2.1-6.

**Table 3.2.1-6 Annual O&M Costs**

Facility	\$/Y (based on 6 Mo Operation)
Labor	75,000
Energy	174,200
Chemicals	25,200
Consumables	24,400
Total O&M Cost	298,800
Contingency (15%)	44,800
<b>Total Annual O&amp;M Cost</b>	<b>343,600</b>

### Life Cycle Cost Analysis

The analysis of life cycle costs for the Shamel Park subterranean HDD well alternative is shown in Table 3.2.1-7. The Cost Analysis uses a cost of money of 3.5 percent for a period of 25 years.

**Table 3.2.1-7 Life Cycle Costs**

Facility	Total
Project Design Life, Year	25
Interest Rate	3.5%
Project Implementation Cost	\$17,941,000
Annual O&M Cost	\$343,600
EUAC	\$1,432,200
Present Worth Life Cycle Cost	\$35,805,000
Future Cost of the Project	\$55,784,000
Cost of Water, \$/AF	5,729

### 3.2.1.8 Summary of Benefits and Issues

The benefits and issues with implementing this alternative are provided as follows.

#### Benefits

- High reliability source of water supply,
- High quality of product water,
- Use of proven technology and standard construction methods, and
- Low impact on the Santa Rosa Creek groundwater basins.

#### Issues

The major potential issues facing this alternative include the following:

- Complicated permitting process,
- Not well known hydro-geological characteristics of Paleochannel C, and

- Relatively high construction and O&M costs.

As a result of CCC's denial on the Coastal Consistency Determination prepared for the proposed geotechnical and geophysical investigations, Board did not select this alternative.

### 3.2.2 Alternative Concept 2 San Simeon Creek Off-Stream Storage

**Abstract:** To increase water supply reliability for the Cambria community, water from San Simeon Creek aquifer would be pumped for storage into off-stream reservoirs. The off-stream reservoirs would store the raw water during wet seasons for its use as potable water supply to the Cambria community during the six month dry season. During the dry season, the stored water would be discharged from the reservoirs, conveyed by gravity flow to the proposed surface WTP, treated, and delivered back to the Cambria community as potable water supply.

#### 3.2.2.1 Alternative Description

Three water storage concepts including:

- In-stream stock ponds,
- Santa Rosa Creek off-stream storage, and
- San Simeon Creek off-storage have been identified and evaluated.

*In-stream stock ponds* –Based on the USGS contour maps, the average width of dominant flows within the creek is approximately 50 ft. With an average stream slope of 0.7 percent and assuming a 4 ft. high stock dam height, there would be 916 ponds required to meet the desired total storage of 1,200 AF. This volume is required to provide storage equivalent to three (3) year water supply and make up water for losses due to evaporation. These stock ponds would occupy almost the entire creek. In addition, installing this many ponds would greatly alter the stream flow and sediment transport dynamics, resulting in significant impacts to the stream stability and its natural habitat. O&M of this huge number of the ponds would be expansive and extremely labor extensive. Therefore, the idea of in-stream stock ponds was not carried forward for further evaluation.

*Santa Rosa Creek off-stream storage* – Three sites for the off-stream storage have been identified in the Santa Rosa Creek watershed that would provide reservoirs with the targeted storage volume of 1,200 AF. Dam heights and storage volumes at the identified sites were similar to the dams and reservoirs identified in the San Simeon Creek watershed. However, locations of the Santa Rosa Creek reservoirs is substantially further inland requiring much longer pipelines and other infrastructure facilities. In contrast, the San Simeon Creek locations of the off stream storage reservoirs are much closer to the existing CCSD water supply facilities requiring shorter pipelines and other infrastructure facilities such as access roads, power supply and communication utilities. Therefore, less expensive and easier to construction off-stream storage alternative concept is proposed for further evaluation.

#### *Description of San Simeon Creek Off-Stream Storage Alternative Concept*

The San Simeon Creek Off-Stream Storage (Off-Stream Storage) alternative concept would involve construction of the off-stream reservoirs within the canyons in the San Simeon Creek lower watershed (See Figure 3.2.2-1). The proposed reservoirs would be used for seasonal water storage to provide an additional dry-season water supply of 250 AF to the Cambria community.

Based upon the draft TM - *Support for In-Stream Flow Study on San Simeon and Santa Rosa Creeks*, CDM Smith, September 2012 (see Appendix A), approximately 1,200 AF of storage would be required to provide a reliable annual yield of 250 AF of water supply to account for losses due to seepage and shortage of watershed supplies during drought. The water to be stored in the Off- Stream Storage reservoirs would be used for the Cambria community water supply during dry weather season.

Key components of the Off-Stream Storage alternative concept include San Simeon Creek water diversion wells, dams and water storage reservoirs, diverted water conveyance pipelines, a surface WTP, a pump station for the product water, and a product water connection pipeline. An overall layout of this alternative is shown in Figure 3.2.2-1. This figure does not show existing Cambria Distribution System Network.

*San Simeon Creek Water Diversion Wells* - To divert and convey 1,200 AF of water from San Simeon Creek to the Off-Stream Storage reservoirs, ten new San Simeon Creek water diversion wells, as well as water conveyance pipelines would be required. These facilities would operate at their full capacities for about 73 days during wet season when high water level in the creek will allow the diversion wells to operate at their full capacity without impacting the basin groundwater. Coarse creek alluvial deposits characterized by high permissivity will allow water diversion from the creek without impacting the groundwater basin. The water diversion wells would be shallow and large diameter wells located in the San Simeon Creek alluvial deposits located within 100 ft. off the creek bed. Four key monitoring wells would be installed to control operation of the diversion wells so that the ground water level will never be lower than set by the basin pumping permit.

*Dams and Water Storage Reservoirs* - To provide safe water yield of 1,200 AF, three rock-fill dams and reservoirs would be needed to store the water diverted from San Simeon Creek. The volume of water losses by reservoir seepage and volume for sediment are included in the 1,200 AF reservoir storage volumes. However, it was estimated that the volume of the water lost through evaporation will be compensated by the water runoffs from the reservoir watersheds. The proposed dams would be constructed with impermeable concrete diaphragm placed on the upstream slope of the dams. To prevent water seepage below dam structure, a below grade grouted curtain (line) would be constructed at each dam site.

*WTP* - The water stored in the Off-Stream Storage reservoirs would be discharged from the reservoirs and treated at a new WTP. The proposed WTP would be typical surface treatment plant consisting of in-line pre chlorination, in-line ferric chloride coagulation, membrane micro/ultrafiltration (MF/UF), and disinfection. Treatment of the WTP process generated waste stream would be an integral part of the proposed WTP, and consist of inclined plate settler and lined sludge drying lagoons. The settled water from the inclined plate settlers would be recycled back at the WTP head-works providing a water treatment facility with zero liquid discharge. The dried sludge would be scraped from the drying lagoons and hauled to landfill for disposal.

*Pipelines* - There would be two main piping systems: 1. Raw water pipeline consisting of Water Diversion Pipeline segment and WTP Raw Feed Water Pipeline segment, and 2. Product Water Connection Pipeline that will interconnect the proposed project facilities and make connection to the CCSD distribution network. The Diversion Water Pipeline segment would connect the water intake wells with storage reservoirs and would be laid out along the San Simeon Creek Road so that each well would deliver the intake water to each of the reservoirs. The WTP Raw Feed Water Pipeline segment would extend downstream of the Reservoir 1 to supply the plant with feed water.

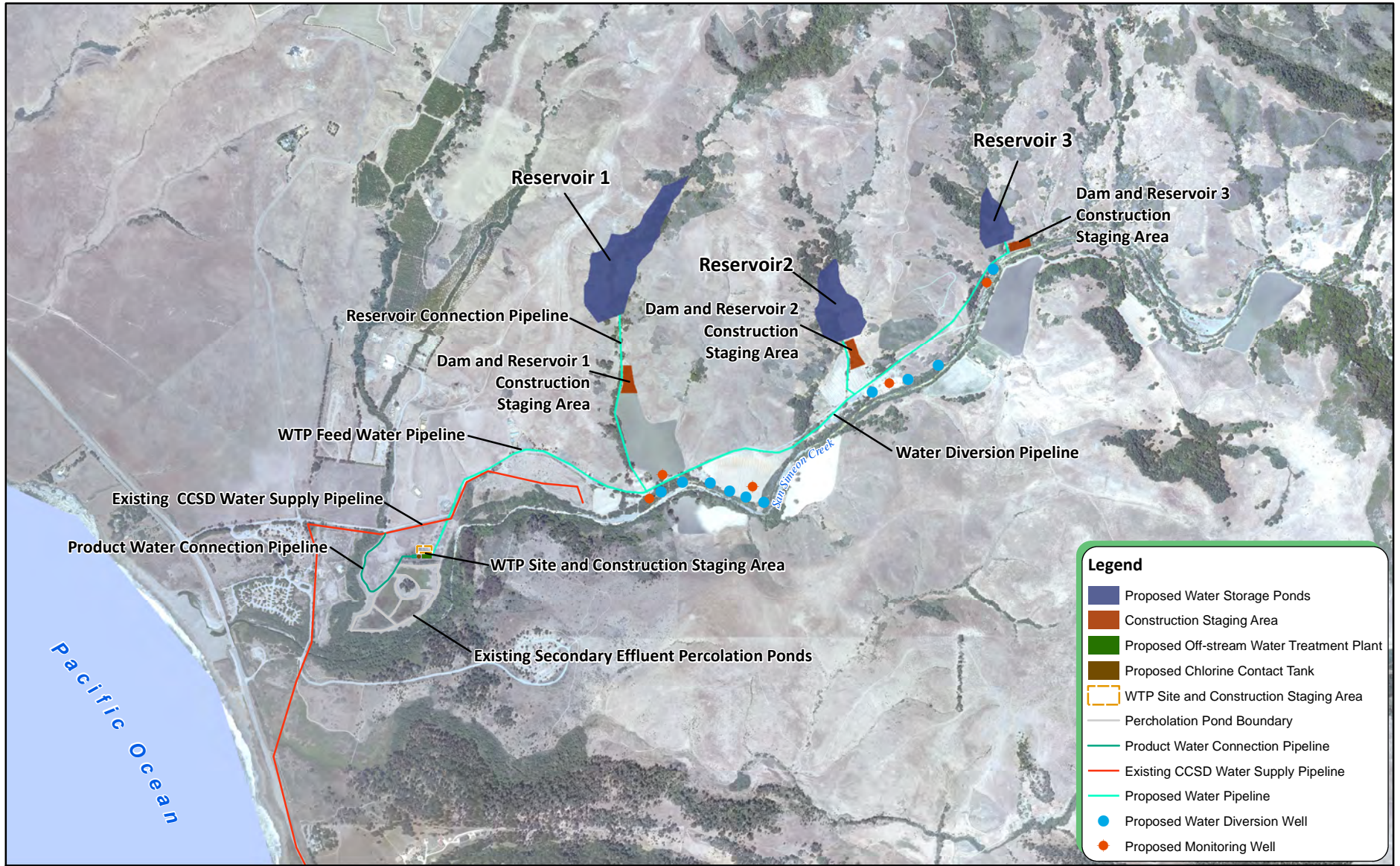

0 500 1,000 2,000  
 Feet  
 1 inch = 2,000 feet



## Cambria Water Supply Technical Memorandum

**Figure 3.2.2-1**  
 Alternative Concept 2  
 San Simeon Creek Off-stream Storage  
 Overall System Layout

The Product Water Connection Pipeline would connect the proposed WTP with the existing CCSD water supply pipeline along the San Simeon Creek Road. The alignment of the Product Water Connection Pipeline would be along the existing access road that connects the San Simeon Creek Road with existing secondary effluent percolation ponds. To pump product water to the existing CCSD water supply pipeline, a product water pump station would be constructed as integral part of the new WTP and associated Chlorine Contact Basin (CCB).

Most of the Off-Stream Storage alternative concepts facilities would be located within the Coastal Zone Boundary, but outside of the limits of state parks and natural conservation areas.

### 3.2.2.2 Flows and Water Mass Balance

The water to be stored in the Off-Stream Storage reservoirs would be the San Simeon Creek diverted water. However, CCSD’s rights to divert water from the creek, design capacities of the reservoirs and the frequency and duration of the available excess flows during the wet weather conditions were important factors when developing the alternative concept.

#### *Rainfall and Runoff in San Simeon Creek*

Stream flow in San Simeon Creek is highly variable with rainfall as the predominant controlling factor. Consequently, flow in the creek is largely a function of rainfall. Table 3.2.2-1 summarizes annual rainfall for the creek watershed and annual runoff based on data from recently monitored downstream SLO County Stations 22 and 16. The average annual runoff on San Simeon Creek is 8,850 AF providing an ample supply of water to the Off-Stream Storage.

**Table 3.2.2-1 Summary of Rainfall and Runoff Data from 1987 through 2004**

Variable	Minimum 1989-90 Water Year	Maximum 1994/95 Water Year	Average
Rainfall (in/yr)*	9.98	44.31	20.15
San Simeon Creek Runoff (AFY)	595	22,879	8,850
Required Flow Diversion , AF	1,200		

\* Rainfall data was obtained from Cambria CFD Station, except for WY 1994-95 when this station was inoperable. Data from the Cal Poly SLO station was used for rainfall depth in WY 1994-95

#### *Permitting and Water Diversion Rights*

Limitations set by the diversion permits issued by the SWRCB as well as a 1981 Coastal Commission-issued Coastal Development Permits are intended to address groundwater pumping rights from the San Simeon Creek and Santa Rosa Creek Basins. These permitting limitations are not expected to apply to this proposed concept due to the fact that the diverted water would originate from the San Simeon Creek channel rather than from the San Simeon Creek basin. Finally, the water would be diverted from the creek for the off-stream storage during wet season when most of the creek flows would be discharged into the ocean.

The shallow water diversion wells that would be located on the creek bank in a close vicinity to the creek channel are recommended due to their ease of construction and low cost. If permitting agencies question this water diversion approach, more expensive and difficult to construct alternative San Simeon Creek water diversion structure may be designed. Regardless, for implementation of this alternative concept, permits from SWRCB, Department of Fish and Game and Division of Dam Safety would be required.

### Off-Stream Storage Capacity

To provide an adequate water supply to account for a multi-year drought, a three year storage capacity should be considered for the Off-Stream Storage alternative. The three reservoirs were sized based upon the site topography and construction feasibility and would provide a combined capacity of just above 1,200 AF, which also includes a buffer for potential water losses and sediment storage. A summary of the storage estimates are presented in Table 3.2.2-2.

**Table 3.2.2-2 Design Capacity for the Off-Stream Storage Reservoirs**

	Unit	Storage Capacity, AF
Reservoir No.1	AF	753
Reservoir No.2	AF	307
Reservoir No.3	AF	162
<b>Total Design Capacity</b>	<b>AF</b>	<b>1,222</b>

### Water Flows for Conveyance and Storage

To establish water volume for conveyance and storage in the Off-Stream Storage reservoirs, six wells would be required for Reservoir No.1, three for Reservoir No.2, and one for Reservoir No.3. The following Table 3.2.2-3 provides summary of storage volume, pumping rates and number of water diversion wells associated with each reservoir.

**Table 3.2.2-3 Water Volume and Flows for Conveyance in Off-Stream Storage**

	Storage Volume AFY	Wet Season Storage Pumping Rate*, gpm	Number of Water Diversion Wells Required (400gpm/ea)
Reservoir No.1	753	2,334	6
Reservoir No.2	307	952	3
Reservoir No.3	162	502	1
<b>Total</b>	<b>1,222</b>	<b>3,788</b>	<b>10</b>

\*Storage pumping rate is based on 73 pumping days

### 3.2.2.3 Water Quality

Although the water to be stored in the off-stream reservoirs is pumped from the proposed water diversion wells, the quality of the diverted water will be similar to that of the San Simeon Creek surface water during high flow conditions, which is characterized by high turbidity and colloidal particulates content. However, the prolong off-stream storage time would allow the turbidity and colloidal particulates to settle at the bottom of reservoir, resulting in stored water quality similar to that found in other man made reservoirs in this geographical area.

The following water quality Table 3.2.2-4 summarizes water quality of the water pumped from the San Simeon Creek, projected quality of the reservoir water that will feed the proposed WTP, and maximum contaminant levels (MCL) for the WTP product water quality. The product water would be typical potable water quality that meets CDPH water quality standards.

**Table 3.2.2-4 Basin Water, Reservoir Stored Water and Final Product Water Quality**

Water Quality Constituent	Unit	Basin Water (San Simeon Creek Water)	Reservoir Stored Water	Product Water MCL
pH <sup>1</sup>	Unit	7.8	7.8	7.5-8.5
Total Dissolved solids <sup>1</sup>	Mg/L	862	862	500
Hardness, as CaCO <sub>3</sub> <sup>1</sup>	mg/L	452	452	<150
Sodium <sup>1</sup>	mg/L	145	145	<250
Chloride <sup>1</sup>	mg/L	266	266	<150
Combined Nitrite and Nitrate (as N), mg/L <sup>1</sup>	mg/L	0.012	0.012	10
Turbidity <sup>2</sup>	NTU	>10	1-10	0.2

1) Average based on water quality data from the 1998 USGS report for San Simeon basin wells 9N2, 8R3 and 8R4

2) Assumed typical values for open channel waters

### 3.2.2.4 Description of System Facilities

The Off-Stream Storage alternative would consist of four major components including, ten San Simeon Creek water diversion wells, three reservoir storage systems consisting of dam, reservoir and water intake structure, water conveyance pipelines, and a WTP including a product water pump station. The facilities of the proposed Off-Stream Storage alternative will be integrated with the existing CCSD water distribution system into one overall integrated CCSD water supply system. The overall system diagram is shown in Figure 3.2.2-2.

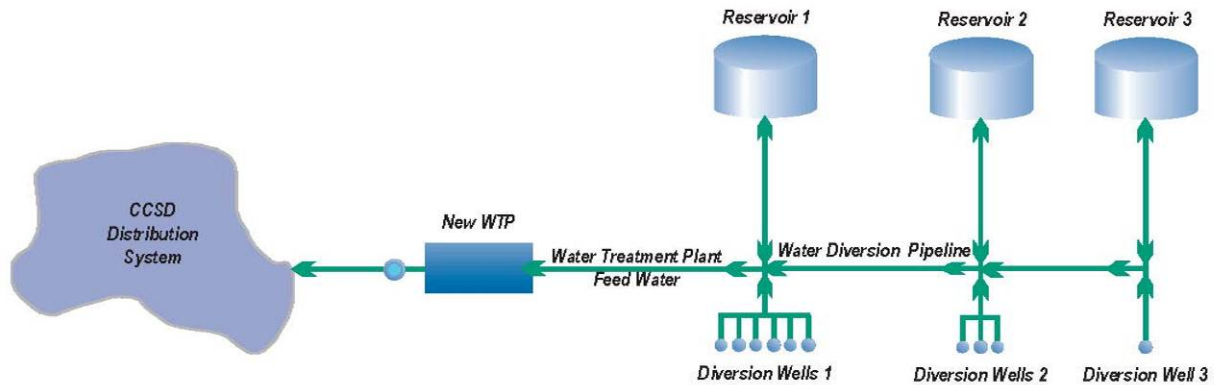

**Figure 3.2.2-2 Off-Stream Storage Alternative Concept - System Process Flow Diagram**

#### System Design Criteria

Key design criteria for each of the key project facilities depicted in the above diagram, are provided in Table 3.2.2-5. Description of each of the system components is provided in the subsequent sections.

**Table 3.2.2-5 Off-Stream Storage Alternative Concept - Design Criteria**

Facility	Unit	Criteria
<b>Off-Stream Storage Dams and Reservoirs</b>		
1 Reservoir No.1	AF	753
2 Reservoir No.2	AF	307
3 Reservoir No.3	AF	162



Table 3.2.2-5 Off-Stream Storage Alternative Concept - Design Criteria

Facility		Unit	Criteria
	Total		1,222
<b>Water Diversion (Intake) Wells</b>			
<b>Wells</b>			
	Number of wells		
	For Reservoir No.1	#	6
	For Reservoir No.2	#	3
	For Reservoir No.3	#	1
	Well construction material		pvc/steel
	Capacity	gpm	377
	Diameter	Inch	18
	Depth	ft	60
<b>Wellhead</b>			
	Reservoir 1 wellhead pump	hp	21
	Reservoir 2 wellhead pump	hp	16
	Reservoir 3 wellhead pump	hp	15
<b>Water Diversion Pipeline</b>			
<b>Reservoir 1 Well Connecting Pipes</b>			
	Average pipe flow rate	cfs	3
	Velocity	fps	4
	Pipe diameter	inch	11
	Pipe length	ft	1,720
	Pipe material		PVC/HDPE
<b>Reservoir 2 Well Connecting Pipes</b>			
	Average pipe flow rate	cfs	1
	Velocity	fps	4
	Pipe diameter	inch	8
	Pipe length	ft	1,100
	Pipe material		PVC/HDPE
<b>Reservoir Diversion Pipeline</b>			
	Pipe flow rate	cfs	8
	Velocity	fps	4
	Pipe diameter	inch	20
	Pipe length	ft	9,800
	Pipe material		PVC/HDPE
<b>WTP Feed Water (Influent) Pipeline</b>			
	Pipe flow rate	gpm	1
	Velocity	fps	4
	Pipe diameter	inch	6
	Pipe length	ft	3,500
	Pipe material		PVC/HDPE
<b>Surface Water Treatment</b>			
	Plant product water capacity	gpm	307

**Table 3.2.2-5 Off-Stream Storage Alternative Concept - Design Criteria**

Facility		Unit	Criteria
	Plant product water capacity	gpd	442,080
	Treatment process		Membrane MF/UF filtration
<b>Pretreatment</b>			
	In-line pre-chlorination	mg/L	2
	In-line coagulation, ferric chloride	mg/L	50
<b>MF/UF Filtration</b>			
	Filter type		MF/UF, pressured flow
	Product		Skid Mounted
	Capacity per skid	gym	0
	Number of skids		2
	Flux	gpdf	65
	Trans-membrane pressure	psi	25
	Backwash frequency	h	24
	Clean-in-place		Citric/sodium hypochlorite
<b>Chlorine Contact Tank (CCT) and product water pump station wet well</b>			
	CCT resident time	min	45
	Tank volume	gallon	13,815
	Break tank type		Bolted steel glass lined
<b>Disinfection</b>			
	Disinfectant		12% sodium hypochlorite
	Avg. dose	mg/l	2
	Residual	mg/L	1
<b>Waste Stream</b>			
	Flow rate	gpm	18
	Decanting		Inclined plate settle
	Sludge concentration	%	3
	Sludge disposal		Sludge drying lagoon
<b>Product Storage Reservoir</b>			
	Storage time	h	12
	Storage volume	gallon	221,040
	Storage tank type		Bolted steel glass lined
<b>Product Water Pump Station</b>			
	Capacity	gpm	307
	TDH	ft	277
	Drive	Type	Constant speed
	Pumping power	hp	30
	Number of pump	#	2
	Wet well		

### Source Water Diversion Wells

The source water intake will be provided by ten new water diversion wells located in vicinity of the San Simeon Creek bed. One diversion well and one monitoring well will be located in the creek area close to the Reservoir 3, three diversion wells and one monitoring well in the area close to the

Reservoir 2, and six diversion wells and two monitoring wells in the area close to Reservoir 1. Each well would have production capacity of 400 gpm with ten wells totaling 4,000 gpm. The diversion wells would be 24-inch diameter and 35 ft. deep. The wells will be constructed of stainless steel and furnished with well pumps and electric motor mounted on a concrete pad.

**Source Water Conveyance Piping**

The source water conveyance piping system would consist of Water Diversion Pipeline segment and WTP Feed Water Pipeline segment. The Water Diversion Pipeline segment will connect water diversion wells with the three storage reservoirs. The WTP Feed Water Pipeline segment would connect the proposed WTP with Water Diversion Pipeline segment to feed the plant with raw water. Total length of the source water conveyance piping system is 16,120 ft. and will be constructed of different pipes sizes. Recommended piping system diameters, lengths, pipe materials and other design criteria for the Source Water Conveyance Piping System are shown in Table 3.2.2-5. The piping alignments of the proposed source water conveyance piping system are shown in Figure 3.2.2-1.

**Off-Stream Storage Reservoirs and Dams**

The Off-Stream Storage would be provided by three reservoirs located within the side stream canyons north of the creek. These reservoirs would be formed by rock-filled dams configured to generate the required storage capacities. Basic layout of the three proposed reservoirs is shown in Figure 3.2.2-3.

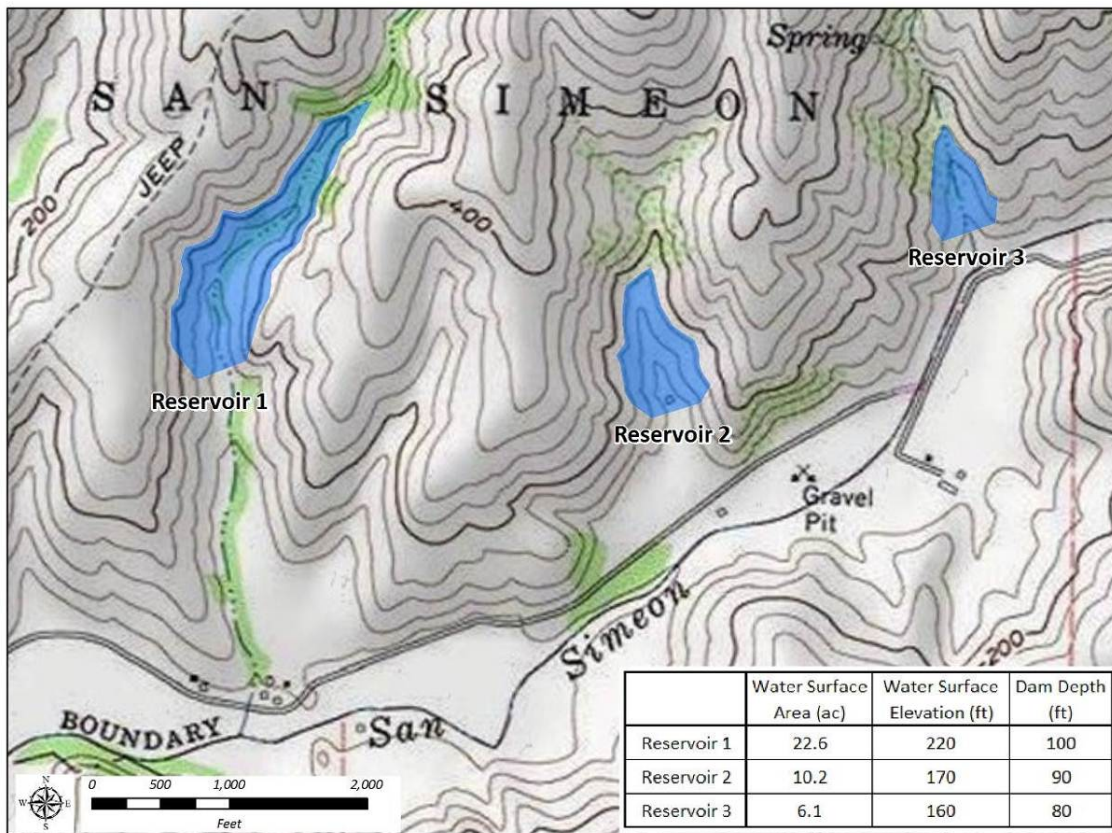

**Figure 3.2.2-3 Off-Stream Storage Alternative Concept - Reservoirs and Dams**

Each of the proposed storage reservoirs consists of rock-fill dam structure with seepage barrier consisting of an upstream water impermeable concrete screen and below grade grouted line

(water impermeable curtain), emergency spillway, water outlet, and water intake structure. Major features of the reservoirs and associated facilities including the storage volumes, inundation areas, dam dimension, seepage barriers, outlets, and spillways, as well as other key design criteria are summarized in Table 3.2.2-6.

**Table 3.2.2-6 Off-Stream Storage Alternative Concept – Dams and Reservoirs**

Dam and Reservoir	Reservoir Depth, ft	Area*, Ac	Volume, AF
Dam & Reservoir No. 1	100	22.6	753
Dam & Reservoir No. 2	90	11.47	307
Dam & Reservoir No. 3	80	6.06	162
<b>Total volume provided</b>			<b>1,222</b>
<b>Dam Structure</b>	<b>1</b>	<b>2</b>	<b>3</b>
Inundation Area (AC)	22.6	11.47	6.06
Storage Vol (AF)	753	307	162
Height (ft)	100	90	80
Length (ft)	590	650	515
Side Slope (H:V)	2.0:1	2.0:1	2.0:1
Top Width (ft)	15	15	15
Base Width (ft)	415	375	335
<b>Seepage Barrier - Dam and Reservoirs</b>	<b>1</b>	<b>2</b>	<b>3</b>
<b>Type</b>	<b>Upstream concrete diaphragm with grouted line</b>		
<b>Upstream Concrete Screen</b>			
Depth, ft	1	1	1
Top length, ft	590	650	515
Bottom Length, ft	130	75	225
Area, sf	80,498	72,952	66,188
<b>Grout Line (below grade impermeable curtain)</b>			
Depth (ft)	75	67.5	60
Thickness (ft)	1.5	1.5	1.5
Length (ft)	590	650	515
<b>Spillways</b>	<b>1</b>	<b>2</b>	<b>3</b>
<b>Type</b>	<b>Open Channel/Trough</b>		
Width, ft	30	33	26
Length, ft	268	241	215
Area, sf	7,916	7,849	5,528
Thickness, ft	2	2	2
<b>Outlet</b>	<b>1</b>	<b>2</b>	<b>3</b>
<b>Type</b>	<b>Trash rack box gate controlled, downstream free flow</b>		
Reservoir emptying flow rate, cfs	127	52	27
Outlet pipe diameter, ft	4	3	2
Length	457	413	369
<b>Water intake</b>	<b>1</b>	<b>2</b>	<b>3</b>
<b>Type</b>	<b>Three level intake with three pips encased in upstream concrete diaphragm</b>		
Capacity, cfs (307 gpm)	0.685	0.685	0.685
Pipe diameter, inch	8	8	8
Pipe length ft	415	375	335

\*Area at maximum water level

### Water Treatment

The new WTP would be designed to produce potable water with a capacity of 307 gpm (estimated based on the demand of 250 AF per year over a 184 day summer season) and run for six months during dry summer season. As shown in Figure 3.2.2-4, the main treatment process of the new WTP include chemical pre-treatment, membrane filtration, filtrate break tank and intermediate pump station, CCT and product water pump station.

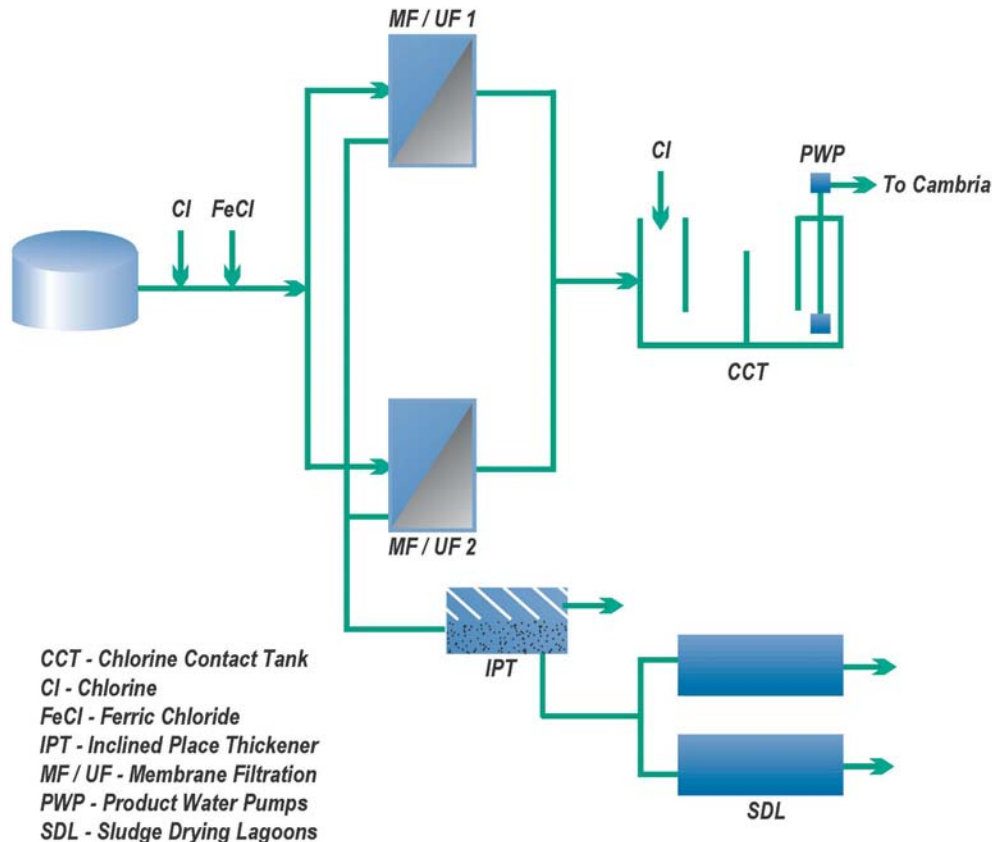

Figure 3.2.2-4 WTP Process Flow Diagram

For the purpose of this report, it is assumed that the new WTP will be located on the CCSD land just north of the existing percolation ponds operated by CCSD.

**Chemical pre-treatment** – It is expected that the chemical pretreatment will be deployed only occasionally during events of elevated turbidity and algae contents in the WTP feed water. Pre chlorination and coagulation with ferric chloride as a coagulant are assumed as the only pre-treatment processes for the new WTP. Principal objectives of the proposed pretreatment are to destabilize colloidal solids and to control algae and particulate content in the source water before filtration.

**Filtration** – MF/UF is assumed as the main treatment process for the new WTP. With sub micron size pores, the assumed MF/UF filtration produces superior product water quality compared to conventional granular media filtration. In addition, the MF/UF requires minimum pretreatment and occupies minimum space for the facility siting. It provides a reliable removal of inorganic and organic

particulates, colloidal particulate materials, pathogenic organics, bacteria and other particles from surface waters.

The assumed MF/UF filtration would consist of hollow tube membrane bundles packed in membrane modules and installed on two MF/UF skids. For the purpose of costing and facility sitting, this report assumed two Model AP-4 units by Pall Corporation skids mounted and ready for installation packaged units that are furnished with all accessories required for membrane cleaning. It is assumed that the MF/UF filtrate will have enough residual pressure to transfer the filtrate flow into the CCT.

*CCT and product water pumps* – A lined steel CCT is assumed to be constructed to provide for product water disinfection. The assumed CCT is sized for 45 minute contact time and would also function as a wet well for the pump station. Two (one duty and one stand by) horizontal split case centrifugal pumps each with a pumping capacity of 307 gpm are proposed to pump the product water from the new WTP to the CCSD’s water distribution system.

*Treatment Plant Site* – The location of the proposed WTP is just north of the existing CCSD percolation ponds, and would occupy an approximate area of 1.25 acres (See Figure 3.2.2-5). All process units would be located in a common building with CCT/product water pump station installed outdoors.

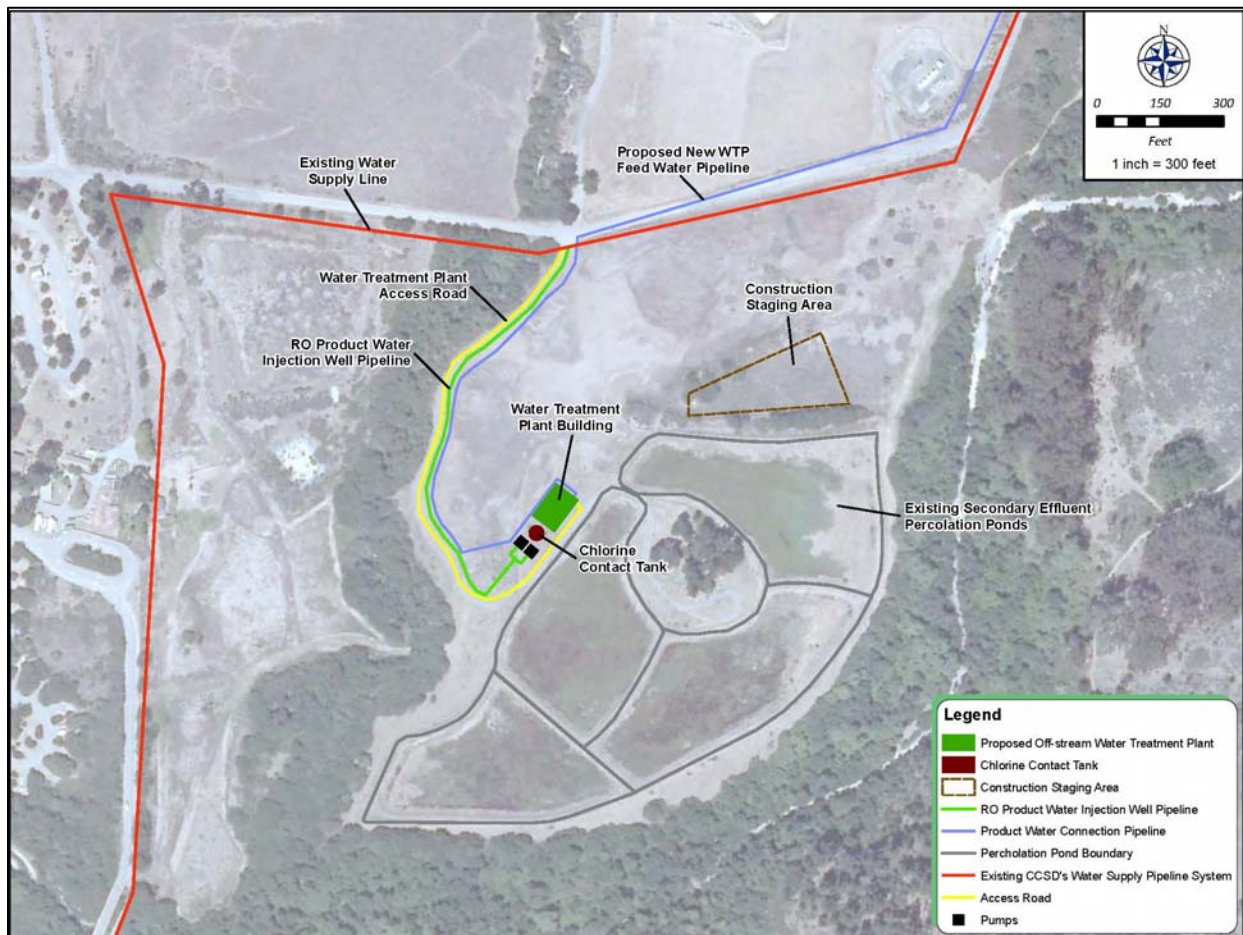

Figure 3.2.2-5 WTP Site Plan

*Access* – Treatment plant access will be from San Simeon Creek Road. The WTP access road alignment is same as for the existing road connecting San Simeon Creek Road with secondary effluent percolation ponds. There will be new on-site parking provided for the operators. The plant will be manned during normal working hours and as needed to operate the plant and perform maintenance and repairs.

*Security* – An eight (8) ft. tall chain-link security fence will be provided at the treatment plant and well sites to protect the facilities. The treatment plant processes will be housed inside a building for added security.

*Buildings* – Almost all of the WTP facilities would be constructed within an engineered prefabricated metal building, reducing noise and visual impacts. The building would be 60 ft. wide, 120 ft. long and 30 ft. tall. The building can be designed and landscaped to blend with the outdoor environment and provide security for facilities.

*Utilities* – Potable water, sanitary sewer and solid waste services will be required. Adequate new power grid and communication lines will need to be available for operation the WTP, water diversion wells and storage reservoirs.

*Waste stream system* – The new WTP plant waste stream will be generated by MF/UF backwashing. It is assumed that the used filter back wash water will be collected and treated by inclined plate settler to separate solids from water. The settled water would be recycled back through the proposed WTP, and solids disposed in two drying lagoons, providing for a zero liquid discharge facility.

*Other miscellaneous wastes* –The other miscellaneous wastes include neutralized clean-in-place solutions, instrumentation analyzer flows, rainwater collected in containment areas, and domestic sanitary sewer from on-site rest room. These flows would be discharged to an on-site septic tank, or the existing wastewater system at State Park.

The treatment plant and pump station would be designed for unmanned operation, However, minimal staffing is assumed for regular working hours from 8:00 am to 5:00 pm.

#### *Product Water Connection to Cambria Distribution System*

The WTP Product Water Connection Pipeline would connect the proposed WTP with the existing CCSD Water Supply Pipeline in San Simeon Creek Road. Alignment of the connecting pipeline would be along the proposed WTP access road. The length of the connecting pipeline would be 1,600 ft. and would be constructed using PVC pipes. Recommended piping system diameters, lengths, pipe materials and other design criteria for the Product Water Connection Pipeline are shown in Table 3.2.2-5, and the piping alignments in Figure 3.2.2-1.

#### 3.2.2.5 Permitting Requirements

Implementation of this alternative would require obtaining approvals or permits from multiple permitting institutions, including but not limited to:

- **SWRCB** - to obtain written approval/permit for water diversion from San Simeon Creek.
- **DWR, Division of Safety of Dams (DSOD)** - to obtain written approval/permit for construction of the three dams and reservoirs.

- **RWQCB** - to address additional pumping requirements from the San Simeon Creek basin during winter wet season.
- **CDPH** - to address source and product water quality requirements and to approve the proposed water treatment process.
- **US Fish and Wildlife Service and California Department of Fish and Game Permits** - Permits may need to be obtained from these two agencies.
- **CCC** – Since a number of the project proposed facilities in Cambria are within the coastal zone, Coastal Commission permitting will be required for consistency with coastal development plan.
- **State Park** – None at this time.
- **Building Permits** - Grading and building permits may be required for the WTP, Cambria Pump Station and water storage reservoir.

### 3.2.2.6 System Construction Requirements

#### *Construction Staging and Traffic Control*

It is anticipated that traffic control plans need to be developed and traffic control measures implemented along San Simeon Creek Road during conveyance pipeline and dam construction activities. Possible traffic control measures may include, but not be limited to, traffic rerouting, construction signs and signals, striping, flagging, detouring, key railing, flagman and others.

Construction staging areas for the WTP and dam construction are shown in Figure 3.2.2-1 and Figure 3.2.2-5. It is estimated that 1.5 acres for WTP and 5 acres for each dam would be required to accommodate construction equipment, material, construction trailers and construction parking lots. Construction staging for pipeline construction will be along San Simeon Creek Road.

#### *Construction Access*

Construction access roads to the three reservoirs and Reservoir Connecting Pipelines would be from San Simeon Creek Road to allow transport of labor, material and construction equipment. Construction access road to the WTP will be from San Simeon Creek Road and will have the same alignment as the existing unpaved access road to the existing secondary effluent percolation ponds. The on-site parking lots will be provided within construction staging areas, as described above.

At the end of the project construction activities, the proposed and above described construction access roads will be converted into permanent access roads. This will be accomplished by paving, striping, and furnishing traffic signs as it is required for the permanent access roads.

#### *Special Material and Equipment*

**WTP** – For the WTP, MF/UF equipment is proprietary equipment and will need to be pre-selected or pre-purchased by CCSD. Other treatment process equipment is readily available and would be part of the general contractor's scope of supply. However, operation of the WTP would require transport and handling of chemicals at the plant site, including sodium hypochlorite, ferric chloride, sodium hydroxide, sulfuric acid and proprietary membrane cleaning solutions.



*Pipeline Construction Equipment* - Pipeline construction will require standard pipeline construction equipment, including backhoes, vibrating compactors, loaders, cranes, utility trucks, and trailer mounted generators.

### *Buildings*

As above described, the WTP buildings would be engineered pre-fabricated metal buildings designed to house all process equipment except CCT and product water transfer pumps.

### *Construction Duration*

The proposed project facilities including water diversion wells, off-storage dams and reservoirs. WTP and all interconnecting pipelines can be bid and constructed as a single project or separate projects due to the differences in the types of facilities and contractors required. The off-stream dams and reservoirs would typically be bid as a separate project from the other facilities due to its unique construction nature. For projects of this complexity, approximately 18 months would be required for the WTP and pipeline construction and up to 36 month for dams and reservoir construction. It is expected that construction hours will be between 7:00 am and 3:00 pm during five (5) week days.

### 3.2.2.7 Engineering Cost Estimates

A planning level engineering cost estimates including capital and operating costs were prepared and are summarized as follows. Detailed cost estimating backup information is provided in Appendix A.

### *Construction Cost*

Summary of the estimate of probable construction cost is shown in Table 3.2.2-7. A construction contingency of 30 percent has been provided. An allowance of 25 percent of the construction cost was added for surveying, geotechnical investigation, engineering design, construction management, permitting, legal fees, and other CCSD administrative and staff expenses. The estimated construction costs are planning level cost estimated to be within -30 percent and +50 percent range.

**Table 3.2.2-7 Conceptual Estimate of Probable Construction Cost**

	<b>Total</b>
Off-Stream Storage Reservoir No.1	\$12,487,000
Off- Stream Storage Reservoir No.2	\$12,571,000
Off-Stream Storage Reservoir No.3	\$8,912,000
Intake Groundwater Wells	\$2,469,000
Water Pipelines	\$2,464,000
Water Treatment Plant	\$2,988,000
Product Water Storage Reservoir	\$575,000
Product Water Pump Station	\$394,000
Subtotal	\$42,860,000
Contingency	\$12,858,000
<b>Total Construction Cost</b>	<b>\$55,718,000</b>
Project implementation cost	\$13,930,000
<b>Total Capital Cost</b>	<b>\$69,647,000</b>

### O&M Cost

The conceptual O&M cost including costs of labor, energy, chemicals and consumables for the Off-Stream Storage alternative have been estimated and are shown in Table 3.2.2-8.

**Table 3.2.2-8 Estimated Annual O&M Costs**

O&M Costing Item	\$/Y (based on 6 Mo Operation)
Labor	\$150,000
Power	\$62,800
Chemicals	\$20,300
Consumables	\$44,700
Total O&M Cost	\$277,900
Contingency (15%)	\$41,700
<b>Total Annual O&amp;M Costs</b>	<b>\$319,600</b>

### Life Cycle Cost Analysis

Life cycle costs for the Off-Stream Storage alternative are shown in Table 3.2.2-9. For the life cycle cost analysis, 3.5 percent discounted rate and 25 years project life time are assumed.

**Table 3.2.2-9 Estimated Life Cycle Costs**

Criteria	Value
Project Design Life, Year	25
Interest Rate	3.5%
Project Implementation Cost	\$69,647,000
Annual O&M Cost	\$319,600
Equivalent Uniform Annual Cost	\$4,545,000
Present Worth Life Cycle Cost	\$113,635,000
Future Cost of the Project	\$177,043,000
Cost of Water, \$/AF	18,181

### 3.2.2.8 Summary of Benefits and Issues

#### Benefits

Major advantages brought by the Off-Stream Storage alternative are as follows:

- High reliability of water sources,
- High quality of water, and
- Use of proven technology and construction methods.

#### Issues

Potential disadvantages facing the Off-Stream Storage Alternative Concept include:

- High construction cost,

- Complex and expensive dam and reservoir monitoring and maintenance. Currently, CCSD does not have expertise and staff for this type of O&M activities,
- Very complex and lengthy permitting process with the State DSOD,
- Substantial and complex land acquisition may slow down and complicate project implementation, and
- Modified SWRCB flow diversion permit will be required.

### 3.2.3 Alternative Concept 3 Morro Bay Shared SWRO

#### 3.2.3.1 Alternative Description

The Morro Bay Shared seawater desalination water supply concept includes the following components:

- Additional seawater intake wells located along the beach in Morro Bay adjacent to the existing City of Morro Bay supply wells,
- A pipeline to convey the seawater from the beach wells to the Morro Bay SWRO facility,
- A shared seawater desalination plant using SWRO as the main treatment process co-located with the City of Morro Bay's existing SWRO facility,
- A concentrate return line from the Morro Bay SWRP facility to the power plant discharge canal that drains to the ocean, and
- A product water pump station and a pipeline that will pump and convey SWRO product water from the treatment plant to Cambria.

The existing Morro Bay SWRO treatment plant is located in Morro Bay, about 18.5 miles south of Cambria. It was originally constructed in 1992 to provide water during a drought emergency. The permit to construct and operate the original plant was expedited to include operation only during a declared emergency but was later amended to include operation to ensure the City of Morro Bay met water quality standards, routine replacement, and drought offset conditions.

The Morro Bay SWRO plant produces water from five seawater wells located along the Morro Bay harbor. In its original configuration, the wells could supply 400 gpm of water to the potable water distribution system.

After its completion in 1992, the plant was only operated for a few months before it was shut down due to excessive operating costs. In 1995, the plant was brought online again to alleviate water shortages during another drought. Currently, the plant is utilized to offset seasonal peaking and for routine supply replacement, such as State Water Project outages, but is planned to be utilized more regularly once ongoing iron fouling issues are resolved. The Morro Bay Shared SWRO water supply alternative facilities are shown in Figure 3.2.3-1. This alternative will share facilities with the existing facility as much as possible, with new or enlarged facilities constructed to allow the increase in capacity for the system as detailed herein.

New beach wells would be required to provide additional seawater to the SWRO plant. They would be constructed along the coast to the west of the plant site. A new pipeline from the beach wells east to the SWRO plant site would be required. The existing SWRO building will not need to be expanded. The CCSD portion of the SWRO facility will include new pumps, energy recovery devices, RO vessels/membranes, piping, electrical, and controls. A new product water pump station in the SWRO building and an off-site pipeline after SWRO treatment would also be required. After leaving the SWRO building the product water pipeline would extend east on Atascadero Road until PCH. At this point, the route of the pipeline would turn north in the PCH ROW and extend 18 miles to Cambria, where it would connect to the existing potable water system. The RO concentrate pipeline would parallel the existing concentrate pipeline to the power plant outfall where a new connection would be made.

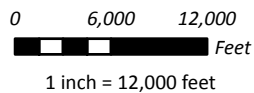
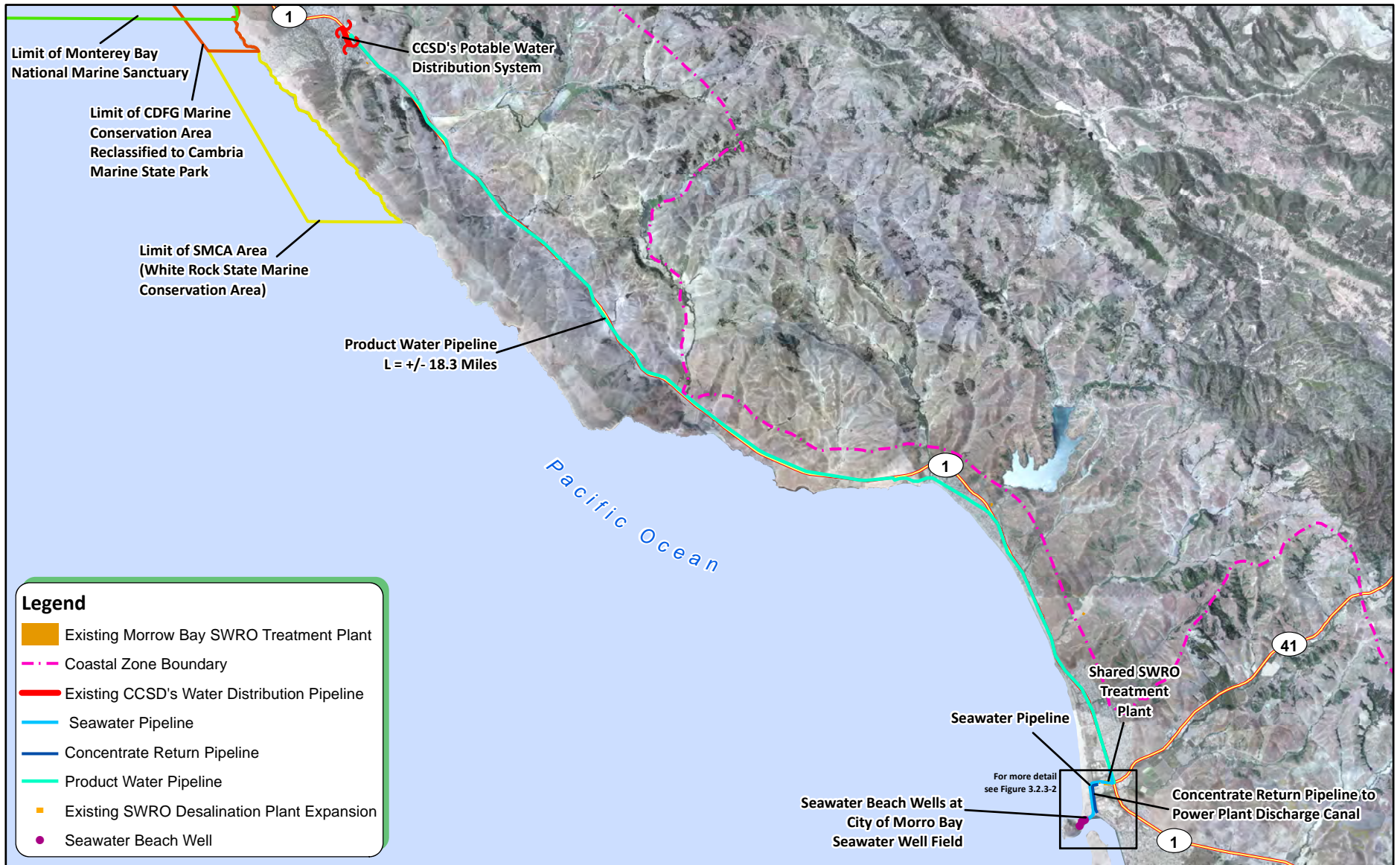

# Cambria Water Supply Technical Memorandum

**Figure 3.2.3-1**  
Alternative Concept 3  
Morro Bay Shared SWRO Overall System Layout



### 3.2.3.2 Flows and Water Mass Balance

This alternative concept would provide a reliable supply of high quality drinking water to the Cambria community during summer dry seasons and during drought year events. Based on the governed SOW, the production capacity of this alternative is 250 AF over a period of 183 days during the dry season. The facility components would be designed to parallel the existing Morro Bay SWRO that would allow operational flexibility to run the system in 62.5 AF increments.

Due to the nature of how RO systems operate, an RO treatment unit typically has a fixed production capacity. Therefore, the production rates of the facility will be primarily determined by the number of RO units included in the design. For the purpose of this TM, it is assumed that the facility would include four equally sized 0.11 MGD RO units and would operate at production capacities of 0.44 MGD.

It is assumed that the RO system would operate at 40 percent recovery. Table 3.2.3-1 summarizes the source water (feed flow from intake), product water flow (RO permeate), and waste stream water flow (RO concentrate for discharge) based on this range of recovery rates and anticipated average and maximum production scenarios.

**Table 3.2.3-1 Flow Rates**

Description	Units	Capacity – 0.44 MGD Production
RO System Recovery	%	40%
Feed Flow From Intake	MGD	1.1
RO Permeate	MGD	0.44
RO Concentrate for Discharge	MGD	0.66

#### *Source Water*

The proposed source water for the Morro Bay Shared SWRO Alternative is seawater from beach wells installed along the coast near the treatment plant. The source water flows extracted from the beach wells would be approximately 621 AF during the dry season at the RO system recovery rates of 40percent.

#### *Product Water Flow*

The product water flow from the Morro Bay Shared SWRO Alternative WTP is 250 AF during six (6) months of dry season.

#### *Concentrate Return Flow*

The volumes and flow rates of the brine generated by RO vary depending on the operation recovery rates. In this TM the concentrate return flow is assumed to be in a range of 375 AF during the dry season at the RO system recovery rate of 40 percent. The concentrate would be returned to the ocean through a new connection to the existing power plant outfall.

### 3.2.3.3 Water Quality

Source water quality determines the selection and design of the pretreatment system, while product water quality goals determine the selection and design of the pretreatment, RO desalination, and post treatment systems. The source water quality assumptions and preliminary product water quality goals for this alternative are provided in the following sections.

### Source Water

The source water of the SWRO plant is from the proposed beach wells installed in the permeable sands along the coast near the treatment plant. Based on the existing Morro Bay SWRO, the assumed water quality data for the source water are summarized in Table 3.2.3-2. The water quality data referenced in the table were obtained from the pilot testing performed in 2002 to resolve the SWRO plant's iron fouling problems (Kartinen & Martin, 2003). Shallow beach wells, typically with a depth of about 50 ft., supply water to the SWRO plant. The static water level is about 10 to 15 below ground surface (bgs).

**Table 3.2.3-2 Water Quality Data for the Source Water**

Description	Units	November 2002
Calcium	mg/L	360
Magnesium	mg/L	840
Sodium	mg/L	6,000
Potassium	mg/L	190
Chloride	mg/L	13,000
Bicarbonate	mg/L	210
Sulfate	mg/L	1,700
Nitrate (as NO <sub>3</sub> )	mg/L	ND
TDS	mg/L	22,000
pH	pH Unit	7.5
Dissolved Iron	mg/L	N.D.
Total Iron	mg/L	2.7
Manganese	mg/L	2.3

As noted in the pilot testing paper, iron fouling has been a problem at the existing SWRO plant and will need to be controlled as part of the shared facility.

### Product Water

Similar to the other SWRO facilities, the preliminary product water quality goals are summarized in Table 3.2.3-3. The parameters that impact selection and design of the RO desalination system are identified in **bold text**. The parameters that impact selection and design of the post-treatment system are identified in *italic text*.

**Table 3.2.3-3 Product Water Quality Goals**

Description	Units	Proposed Goals	Regulatory Limit
TDS	mg/L	<250 from RO; <330 after post-treatment	≤500
Chloride	mg/L	<140 <sup>1</sup>	≤250
Boron	mg/L	<1.0 <sup>1</sup>	≤1.44
Bromide (if applicable for DBP control)	mg/L	<0.5	TTHM: <0.080 HAA5: <0.060
Hardness	mg/L as CaCO <sub>3</sub>	40-50	n/a
Alkalinity	mg/L as CaCO <sub>3</sub>	40-60	n/a
pH	pH Unit	Match pH in distribution system (assumed to be approximately 8.0; confirm with CCSD)	6.5-8.5
Free Chlorine Residual	mg/L	Match residual in distribution system (assumed to be approximately 1.0)	<4.0
Langlier Saturation Index	LSI Unit	> - 0.5 or add corrosion inhibitor	Non-corrosive

Notes:

<sup>1</sup>These values are the recommended limits for water used to irrigate the majority of ornamental and garden plants in California.

### 3.2.3.4 Description of System Facilities

The Morro Bay Shared SWRO alternative consists of five key new facilities including beach wells, source water pipeline, treatment plant, concentrate pipeline, product water pump station and pipeline to Cambria.

#### System Design Criteria

The design criteria for each of the major new facilities, including intake, treatment plant, and product water conveyance, as well as concentrate return, are provided in the following Table 3.2.3-4.

Description of each of the system components is provided in the subsequent sections.

**Table 3.2.3-4 Design Criteria**

Facility	Units	Criteria
<b>Seawater Intake Facilities</b>		
Seawater Intake	Type	Beach Wells
Number of Wells	#	3
Well Diameter	in	12
Well Depth	ft	60
Well Spacing	ft	250-300
Well Production	gpm	250
Well Pump TDH	ft	141
Pump Horsepower	Hp	15
<b>Seawater Source Pipeline</b>		
Pipe Flow Rate	gpm	769
Velocity	fps	3.1
Diameter	in	10
Length	ft	4,900
Pipe Material	Type	PVC/HDPE
<b>Seawater Treatment Plant</b>		
Days of Operation	days	184



**Table 3.2.3-4 Design Criteria**

Facility	Units	Criteria
Annual Plant Source Water	AFY	625
Annual Plant Product Water	AFY	250
Plant Product Water Capacity	MGD	0.44
Plant Product Water Capacity	gpd	442,080
Plant Product Water Capacity	gpm	307
<b>Seawater Pretreatment – Iron Removal</b>		
Process	type	oxidation/filtration
Capacity	gpm	769
Oxidation	type	chlorine
Dechlorination	type	sodium bisulfite (NaHSO <sub>3</sub> )
Filtration		Filtronix Media Filter
<b>SWRO Treatment Plant</b>		
<b>Pretreatment – Particulate Removal</b>		
Type		1 micron Cartridge Filter
Number of Cartridge Filters	ea	2
Capacity per Cartridge Filter	gpm	576
<b>Pretreatment – Chemical Pretreatment</b>		
pH Adjustment	type	Sodium hydroxide (NaOH) Sulfuric acid (H <sub>2</sub> SO <sub>4</sub> )
Antiscalant	type	Proprietary threshold inhibitor
<b>SWRO</b>		
Skid Number	#	4
Skid Capacity (each)	gpm	192
Configuration		Single pass/two stage
Membrane Elements	size/type	8-inch SWRO membrane
RO Design Recovery	%	40
Flux	gfd	8
Capacity/permeate flow per skid	gpm	77
<b>RO Feed Pumps</b>		
RO Feed Pump Capacity	gpm	77
Number of RO Feed Pumps	ea	4
TDH	psi	1000
Drive	type	VFD
Pump Horsepower	Hp	75
Number of Pumps	ea	4
<b>Energy Recovery</b>		
Energy Recovery Device	type	Pressure exchange (PX) or Work exchanger
Efficiency	%	95
RO Booster Pump Capacity	gpm	115
RO Booster Pump Horsepower	hp	5
<b>Product Water Post Treatment/Stabilization</b>		

**Table 3.2.3-4 Design Criteria**

Facility	Units	Criteria
pH and Alkalinity Adjustment		CO <sub>2</sub>
Remineralization		CaCO <sub>3</sub> Contactor
<b>Disinfection</b>		
Primary Disinfectant	type	UV light
Virus Inactivation and Residual	type	Sodium hypochlorite (NaOCl)
<b>Concentrate Return</b>		
Concentrate Flow Rate	gpm	462
Concentrate Flow Rate	gpd	664,050
Driving Pressure	psi	(RO concentrate residual pressure)
Pipe Flow Velocity	fps	3.0
Pipe Diameter	in	8
Pipe Length	ft	3,600
Pipe Material	type	PVC
<b>Product Water Pump Station</b>		
Pump Capacity	gpm	307
TDH	ft	507
Drive	type	constant speed
Horsepower	Hp	150
Number of Pumps	ea	2
Pump	type	horizontal split case
<b>Product Water Pipeline</b>		
Pipe Flow Rate	gpm	307
Velocity	fps	3.5
Diameter	in	6
Length	ft/miles	97,680/18.5
Pipe Material	type	steel/HDPE

**Source Water Intake**

The source water intake would be provided by the construction of three new beach wells similar to the existing beach wells. The additional new wells would be spaced approximately 250-300 ft. apart to reduce potential drawdown impacts between wells and would be constructed along the Morro Bay coast in Coleman Drive further southwest of the existing beach wells as shown in Figure 3.2.3-2. The wells would be similar construction and depths to the existing beach wells.

**Source Water Transmission**

The source water is conveyed through an approximately one mile long, ten (10) inch diameter pipeline from the beach wells to the existing Morro Bay SWRO treatment plant site. The pipeline would be laid out in Coleman Drive and Atascadero Road (Figure 3.2.3-2).



**Figure 3.2.3-2 Alternative Concept 3 Seawater Intake SWRO Plant and Pipeline Connection Detail**

### Water Treatment

Similar to the other SWRO projects described in this document, pretreatment refers to the treatment process upstream of the desalination system, which filters and conditions the water to prevent rapid clogging and fouling of the RO membranes in the desalination process. In addition to complying with regulatory and RO membrane warranty requirements, the following typical pretreatment water quality goals should be reached by the pretreatment facilities:

- Turbidity of 0.1 NTU or less,
- TOC concentration of 2.0 mg/L or less,
- SDI goal of 4.0 SDI15 units or less, and
- Iron concentrations 0.05 mg/L or less.

In general, Pacific Ocean water has good quality and is easy to pre-treat and desalinate. The source water quality of the beach wells is usually low in turbidity, SDI, and TOC compared with open ocean intake. The most remaining foulants (e.g., sand and suspended scaling minerals) are expected to be removed by the wells screens and cartridge filters or sequestered by the antiscalant chemical before RO desalination. The minimal pretreatment process is assumed for the new SWRO plant with optional chemical injections and cartridge filters. Iron pretreatment will be provided since it was required for the existing Morro Bay SWRO plant. Process schematic of the pretreatment process and the subsequent RO desalination and post treatment process is similar to the schematic shown in Figure 3.2.1-2 from Shamel Park Seawater Concept.

Positive displacement pumps typically provide high operating efficiencies and are limited to membrane unit capacities of approximately 1.0 MGD or less for high-pressure seawater applications. Positive displacement pumps are recommended for the SWRO plant for their LE usage and stable operation during potential seasonal variations in source water salinity. Four high efficiency pumps and motors with capacity of 77 gpm are assumed for this project. The remainder of the feed water would be pumped with the ERD's and associated booster pumps.

The new SWRO treatment plant is sized for a product water capacity of 307 gpm and would run for six months during the dry summer season. The desalination process utilizes a single-stage single-pass configuration for the SWRO membranes that typically has the lowest equipment cost and energy use. A single-stage system is limited to a maximum operating recovery of 40 to 50 percent recovery to maintain efficient operation when treating seawater with a TDS of approximately 30,000 to 35,000 mg/l.

This TM assumes four (4) RO membrane units each with a capacity of 0.11 MGD (77 gpm) to be similar to the existing Morro Bay SWRO RO units. The RO projection included in the design was based on seven LE membrane elements (e.g., SWC5) in each vessel to optimize the balance between boron removal and power consumption. The design basis reflects the use of standard conventional eight (8) inch diameter by 40-inch long seawater RO elements. Each membrane unit will have 24 pressure vessels installed and will be configured to accommodate the installation of a total of 28 vessels. Each pressure vessel will contain seven membrane elements, for a total of 168 elements per unit. Each membrane unit will include all pressure vessels, membrane elements, supporting frame, sample panels, on-board instrumentation and associated panels, piping, valves and actuators, and all necessary appurtenances.

ERD's are machines designed to recover and reuse the stored hydraulic energy in the RO concentrate stream. Without an ERD, the high pressure pumps provide 100 percent of the flow and 100 percent of the feed pressure. An isobaric ERD, such as an ERI PX or DWEER Work Exchanger is assumed for the RO processes. The ERD recovers 95 to 98 percent of the energy from the concentrate, using it as the primary boost for 60 percent of the feed water flow. An additional boost must be provided downstream of the ERD's to account for minor inefficiencies in the devices as well as hydraulic losses in the membranes and membrane piping.

Due to the relatively small size of this facility, it is recommended that the RO units be configured as independent membrane units with a dedicated HP RO pump and energy recovery system for each membrane unit.

RO permeate is corrosive and requires stabilization and re-mineralization before it is pumped into the distribution system. Post-treatment process includes a CO<sub>2</sub> injection system, calcite contactors, and caustic soda to adjust pH and create bicarbonate alkalinity as well as calcium hardness. CO<sub>2</sub> is usually delivered as a compressed, liquefied gas and stored on-site in a pressurized vessel. The CO<sub>2</sub> calculated uses rate is 180 lbs/day. The RO permeate passes through the calcite bed in the calcite reactors and forms [Ca(HCO<sub>3</sub>)<sub>2</sub>]. The empty bed contact time will be designed for 10 to 15 minutes. The advantage of calcite contactors is that no over dosage of the chemical can occur and the facilities require very low maintenance compared with lime feed systems.

The proposed disinfection system includes UV disinfection to provide additional disinfection of Cryptosporidium and Giardia, and NaOCl disinfection to provide additional virus disinfection as well as a disinfectant residual in the distribution system.

### *Waste Stream System*

In a typical SWRO system, 40 to 50 percent of the seawater that is fed to the reverse osmosis (RO) system passes through the membranes and becomes high purity drinking water. Because approximately half of the water is removed from the remaining seawater stream while majority of the dissolved salts are retained, this stream becomes more concentrated and is called the RO concentrate (a.k.a., brine) stream. The RO concentrate flow will be returned to the ocean through a new conveyance pipeline to the existing power plant outfall.

### *Product Water Transmission and Connection to CCSD Distribution System*

The product water would be pumped from the clear well during dry seasons to the CCSD's existing potable water distribution system. The length of the product water transmission pipeline is approximately 18.5 miles and pipe diameter 6 inch (Figure 3.2.3-1). The pipeline is proposed to be constructed along PCH between Morro Bay and Cambria. The product water pipeline would connect to the southern end of the CCSD's distribution system.

#### 3.2.3.5 Permitting Requirements

Implementation of this alternative would require obtaining permits from multiple permitting institutions including but not limited to:

- **CCC** - permitting would be required for consistency with coastal development plan since the entire project is within the Coastal Zone boundary.
- **RWQCB** - to address the potential impact of the new beach wells.
- **CDPH** - to address source water and product water quality requirements and to approve the proposed water treatment processes.
- **Building Permits** – Grading and building permits may be required for the SWRO treatment plant.
- **City of Morro Bay/Morro Bay-Cayucos Wastewater District** – construction permits may be required for beach wells and treatment plant.

#### 3.2.3.6 System Construction Requirements

Due to the relatively small size of the SWRO system, the four membrane units can be installed as a single skid to conserve space, but be separated with valves and piping to operate as independent units to provide operational flexibility.

The construction of beach wells will utilize “open hole” technology, which means that the drilling fluid is required to hold the borehole open during drilling and construction. Drill pipe and down-hole tools are used to advance the borehole, while the drilling fluid is used to cool and lubricate the bit, stabilize the borehole, and carry cuttings (formation material) to the surface. Drilling of the borehole is generally achieved in two stages: drilling the small diameter pilot borehole, followed by enlarging the pilot borehole in one or more reaming passes to the diameter required to contain the casing, screen, and filter pack. Once the total lineal length and depth is reached, the pilot borehole is reamed by pushing and rotating the drill bit as it follows the pilot bore to its completion depth.

### *Staging Location and Area*

All staging areas of the proposed SWRO plant would be on the Morro Bay-Cayucos SD owned land on their WWTP. Since the new SWRO system will be constructed within the existing SWRO building, there shouldn't be any major facilities outside of the building. The staging locations for equipment, materials and construction worker parking would be on flat areas around the WWTP and SWRO process building.

For the beach wells, the staging locations will also be on the Morro Bay-Cayucos WWTP land. An approximately 50 ft. x 100 ft. site will be needed to drill the beach wells.

### *Construction Accessibility*

Construction access for the SWRO treatment plant would be from Atascadero Road off PCH. Access to the proposed SWRO treatment plant site would be through the existing entrance to the Morro Bay Cayucos WWTP for water trucks, cranes, equipment transportation trucks, and construction laborers. Adequate on-site parking during construction would be provided.

Construction access for the drilling location in the beach wells would be from adjacent paved roadways (i.e., Atascadero Road, Coleman Drive and PCH). The drilling work area and the equipment staging area would be surrounded by a temporary six ft. high chain link fence. The public would be affected from accessing beach areas reserved for drilling equipment. The portion of the beach used for drilling activities would be closed to the public during the construction process. Use of nearby beach areas would not be restricted during the work, and will not be impacted.

### *Special Material and Equipment Requirements*

For the treatment plant, the UV equipment is proprietary and would need to be pre-selected or pre-purchased. Other equipment is readily available and will be part of the general contractor's scope of supply. Operation of the SWRO treatment plant would require transport and handling of chemicals at the plant site, including sodium hypochlorite, sodium hydroxide, antiscalant, carbon dioxide, and various cleaning solutions.

The beach well screens would use 5/16-inch thick super duplex 2507 stainless steel materials with horizontal louvered openings. This stainless steel alloy will provide excellent corrosion resistance and prevent failure over the 25-year life of the project.

The treatment plant construction equipment would consist of standard commercial construction equipment, including, scrapers, graders, dozers, back hoes, vibrating compactors, loaders, cranes, forklifts, utility trucks, concrete trucks, and trailer mounted generators.

The beach well construction equipment would consist of drilling equipment, gyroscopic steering device, temporary tanks, pumps, cranes, utility trucks, trailers and mounted generator.

Pipeline construction equipment would consist of standard pipeline construction equipment, including backhoes, vibrating compactors, loaders, cranes, utility trucks, and trailer mounted generators.

### *Construction Duration*

The proposed SWRO treatment plant, seawater beach wells, concentrate return, and source water and product water pipelines can be bid and constructed as a single project or separate projects due to the differences in the types of contractors required. For a project of this size and magnitude,

approximately a 16 to 18 month construction period is required assuming a five day per week schedule. Daily hours for construction activities would be limited by the County of SLO or City of Morro Bay construction permits. However, it is expected to be between 7:00 am and 4:00 pm. Construction of the different facilities can be ongoing at the same time. Construction must be completed of all facilities by the start of treatment plant testing.

### 3.2.3.7 Engineering Cost Estimates

Planning level engineering cost estimates including capital and operating costs are prepared and summarized as follows. Detailed cost estimating backup information is provided in the Appendix A.

#### Construction Cost

Summary of the estimate probable construction costs is shown in Table 3.2.3-5. A construction contingency of 30 percent has been provided. An allowance of 25 percent of the construction cost is added for surveying, geotechnical investigation, engineering design, construction management, permitting and legal fees, and CCSD administrative and staff expenses.

**Table 3.2.3-5 Conceptual Estimate of Probable Construction Costs**

Facility	Total	
Seawater Intake (beach wells)	\$1,200,000	
Seawater Pipeline	\$735,000	
Morro Bay SWRO Treatment Plant	\$4,002,000	
SWRO Pretreatment - Iron Removal	\$884,000	
Concentrate Return	\$432,000	
Product Water Pump Station	\$1,265,000	
Product Water Pipeline	\$8,791,000	
Subtotal	\$17,309,000	
	Contingency (30%)	\$5,193,000
<b>Total Construction Cost</b>		<b>\$22,502,000</b>
	Project Implementation Cost (25%)	\$5,625,000
<b>Total Capital Cost</b>		<b>\$28,127,000</b>

#### O&M Cost

The conceptual O&M costs for the Morro Bay Shared SWRO alternative is shown in Table 3.2.3-6.

**Table 3.2.3-6 Annual O&M Costs**

Facility	\$/Y (based on 6 Mo Operation)	
Labor	\$75,000	
Power	\$189,000	
Chemicals	\$20,300	
Consumables	\$44,700	
Total O&M Cost	\$329,000	
	Contingency (15%)	\$50,000
<b>Total Annual O&amp;M Cost</b>		<b>\$378,500</b>

### Life Cycle Cost Analysis

The analysis of life cycle costs for the Morro Bay Shared SWRO recycled water alternative is shown in Table 3.2.3-7. The Cost Analysis uses a cost of money of 3.5 percent for a period of 25 years.

**Table 3.2.3-7 Life Cycle Costs**

Facility	Total
Project Design Life, Year	25
Interest Rate	3.5%
Project Implementation Cost	\$28,127,000
Annual O&M Cost	\$378,500
EUAC	\$2,085,000
Present Worth Life Cycle Cost	\$52,127,000
Future Cost of the Project	\$81,214,000
Cost of water, \$/AF	8,340.00

### 3.2.3.8 Summary of Benefits and Issues

The benefits and issues with implementing this alternative are provided as follows.

#### Benefits

- High reliability of water sources,
- High quality of water,
- Use of proven technology and easy construction,
- Minimal disturbance on marine life by beach wells, and
- Efficiency in using existing SWRO infrastructure and co-locating new facility with existing SWRO plant.

#### Issues

The major potential issues facing this alternative include the following:

- Relatively higher construction costs and O&M costs,
- Agreement with other agencies required to co-locate facilities,
- Long pipeline in Caltrans ROW,
- Permitting for source water beach wells and concentrate return, and
- Change of the Power Plant's one-through cooling system may require alternative concentrate return method.

This alternative was not favored by the CCSD board, however, due to NEPA requirements it is being evaluated in the EIS/EIR.



## 3.2.4 Alternative Concept 4 Estero Bay Marine Terminal

### 3.2.4.1 Alternative Description

The Estero Bay Marine Terminal Concept would use seawater as the source of water supply and the project facilities would consist of a subterranean HDD well seawater intake, a seawater pipeline, a SWRO desalination plant, a product water pump station and pipeline, and concentrate return pump and pipeline. A layout of these project components are shown in Figure 3.2.4-1 and Figure 3.2.4-2.

The Estero Bay Marine Terminal is located within the City of Morro Bay, approximately 16.5 miles southeast of Cambria and was owned and operated by Chevron Oil Corporation. The marine terminal was constructed in 1920 and decommissioned in 1999. There were two oil tanker loading pipes extending several thousand ft. offshore, and one ocean outfall used to discharge wastewater from the on-shore crude oil processing facility into ocean. An initial search for construction documents and an attempt to field identify locations of the Estero Bay Marine Terminal pipes was not successful. Since Chevron Corp is also under a court order to clean up the entire terminal area including demolition of the offshore piping, the idea to use the old terminal pipe for seawater intake and concentrate return has been dropped from further considerations.

The HDD seawater intake well would be installed offshore below the ocean floor in permeable sediments of a Paleochannel extending off shore from the Toro Creek mouth. Entry pits for the HDD well would be located east of PCH and would cross underneath the existing dog beach area without beach disturbance (see Figure 3.2.4-2).

The seawater pipeline would be aligned along Toro Creek Road easterly from the HDD well entry pit. The SWRO plant would be located off Toro Creek Road and inland from the Coastal Zone boundary. The SWRO concentrate would be returned back to the ocean via the existing Morro Bay power plant cooling water return canal. The concentrate pipeline would be laid westerly from the SWRO plant along Toro Creek Road and southerly along PCH, and then through the streets of Morro Bay to the connection with the power plant cooling water return canal.

The product water conveyance pipeline would begin from the SWRO desalination plant and be laid westerly approximately one mile along Toro Creek Road. The product water pipeline would then run northerly along PCH to join the existing CCSD's potable water distribution system.

#### *Technical Feasibility Assessment*

A geotechnical report would be needed to specifically confirm the existence and underground characteristics of the Toro Creek paleochannel and whether it is suitable for a water supply source. Such information would be critical in further defining and determining the feasibility of this water supply concept. Other project facilities including the SWRO plant, concentrate return and associated pipeline are technically feasible and could be constructed within acceptable costs.

This alternative concept would reliably provide a supply of high quality drinking water to the Cambria community during summer dry seasons and during drought years. The production capacity of SWRO would be 250 AF over a period of six (6) months or 442,000 gpd (307 gpm). Assuming an RO recovery rate of about 40 percent, the sea water intake would have capacity of 1.1 MGD. The facility components would also be designed to allow operation at a reduced capacity to supplement existing supplies during other times of the year.



0 4,500 9,000



Feet

1 inch = 9,000 feet

**CDM  
Smith**

## Cambria Water Supply Technical Memorandum

**Figure 3.2.4-1**  
Alternative Concept 4  
Estero Bay Marine Terminal  
Overall System Layout



**Figure 3.2.4-2 Estero Bay Marine Terminal Seawater Intake and SWRO Plant site**

As a result, it is assumed that the facility would include two equally sized RO units, which would operate daily during six (6) dry season months.

The SWRO feed water would be extracted from the permeable sediments in Toro Creek Paleochannel through the HDD well that would be drilled from the access pit located at an open lot just east of PCH. The SWRO concentrate would be returned back in the ocean via the existing cooling water return canal at the Morro Bay power plant.

### 3.2.4.2 Flows and Water Mass Balance

The production capacity of this alternative is 250 AF over a period of six months during the dry season, equivalent to 0.44 MGD. The facility components will be designed to allow operation at a reduced capacity as needed to supplement existing supplies during other times of the year.

An SWRO treatment unit typically has a fixed production capacity. Therefore, the production rates of the facility will be primarily determined by the number of RO units included in the design. For the purpose of this report, it is assumed that the facility would include two equally sized 0.22 MGD RO units and operate at production capacities of either 0.22 or 0.44 MGD.

Table 3.2.4-1 summarizes the source water (SWRP plant influent flow rate), product water flow (SWRO permeate), and waste stream water flow (RO membrane concentrate for discharge) based on this recovery rate and anticipated average and maximum production scenarios.

**Table 3.2.4-1 Flow Rates**

Description	Units	Peak Capacity – 0.44 MGD Production
RO System Recovery	%	40%
Feed Flow Rate From Intake	MGD	1.1
RO Permeate	MGD	0.44
RO Concentrate for Discharge	MGD	0.66

### *Source Water*

The source water for the Estero Bay Marine Terminal Alternative would be seawater extracted from the subterranean HDD drilled well intake installed offshore below the ocean floor in permeable sediments of a Paleochannel extending off shore from the Toro Creek mouth. The source water influent flows to the SWRO would be 625 AF during the dry season at the RO system recovery rates of 40 percent.

### *Product Water Flow*

The product water flow from the Estero Bay Marine Terminal SWRO WTP is 250 AF during six (6) months of dry season for potable water supply to Cambria’s water distribution system.

### *Waste Stream Water Flow*

The volume and flow rate of the concentrate generated by the RO treatment plant would be 373 AF or 0.66 MGD, during the dry season at the RO system recovery rate of 40 percent. The concentrate return flow would be returned to the ocean via the existing Morro Bay power plant cooling water return canal.

### 3.2.4.3 Water Quality

Selection and design of the pretreatment system would depend upon the water quality of the source water, while selection and design of the RO desalination and post treatment systems would depend on the quality of the product water. The assumed source water quality and the preliminary product water quality goals for this alternative are provided in the following sections.

### *Source Water*

The source water of the SWRO plant would be from the proposed subterranean intake installed in the permeable sediments on the ocean floor. Based on similar projects with source water extracted from the subterranean seawater intakes in the Pacific Coast area, the assumed water quality data for the source water are summarized in Table 3.2.4-2.

It is currently unknown if iron and/or manganese would be present at concentrations greater than 0.05 mg/L from a subterranean HDD well.

### *Product Water*

The preliminary product water quality goals are summarized in Table 3.2.4-3. The parameters that impact selection and design of the RO desalination system are identified in bold text. The parameters that impact selection and design of the post-treatment system are identified in italic text.

**Table 3.2.4-2 Assumed Source Water Quality**

Description	Units	Source Water Quality Average (Range)
TDS	mg/L	35,000 (34,000 to 36,000)
Temperature	Degree C	14 (12 ~ 16)
pH	pH Unit	8.0 (7.9 to 8.1)
Turbidity	NTU	<0.2 (0.1 to 1)
TOC	mg/L	<1.0 (0.5 to 1.0)
Hardness	mg/L as CaCO <sub>3</sub>	>120
Silt Density Index (SDI)	SDI15 Unit	<3
Chloride	mg/L	19,000 (18,000 to 20,000)
Bromide	mg/L	Average: 65
Boron	mg/L	4.5 (4.0 to 5.0)
Iron	mg/L	Unknown
Manganese	mg/L	Unknown

**Table 3.2.4-3 Product Water Quality Goals**

Description	Units	Proposed Goals	Regulatory Limit
TDS	mg/L	<250 from RO; <330 after post-treatment	≤500
Chloride	mg/L	<140 <sup>1</sup>	≤250
Boron	mg/L	<1.0 <sup>1</sup>	≤1.44
Bromide (if applicable for DBP control)	mg/L	<0.5	TTHM: <0.080 HAA5: <0.060
Hardness	mg/L as CaCO <sub>3</sub>	40-50	n/a
Alkalinity	mg/L as CaCO <sub>3</sub>	40-60	n/a
pH	pH Unit	Match pH in distribution system (assumed to be approximately 8.0; confirm with CCSD)	6.5-8.5
Free Chlorine Residual	mg/L	Match residual in distribution system (assumed to be approximately 1.0)	<4.0
Langlier Saturation Index	LSI Unit	> - 0.5 or add corrosion inhibitor	Non-corrosive

Notes:

These values are the recommended limits for water used to irrigate the majority of ornamental and garden plants in California.

#### 3.2.4.4 Description of System Facilities

The Estero Bay Marine Terminal Concept consists of five key new facilities including subterranean seawater intake HDD well and well pumping system, seawater water pipeline, SWRO treatment plant, concentrate return pipeline, product water pump station, and pipeline to Cambria.

#### System Design Criteria

The design criteria for each of the facilities, including intake, treatment plant and product water conveyance, as well as concentrate return, are provided in the following Table 3.2.4-4. Description of each of the system components is provided in the subsequent sections.

**Table 3.2.4-4 Design Criteria**

Facility		Unit	Criteria
<b>Seawater Intake</b>			
	Seawater intake	Type	HDD
	Number of HDD wells	#	1
	Well diameter	inch	12
	HDD well length	ft	1,300 -1,400
	Well screen length	ft	±200
	Well Production	gpm	768
	Well Production	MGD	1.105
	Well pump TDH	ft	181
	Pump horsepower	HP	49
<b>Seawater Pipeline</b>			
	Pipe flow rate	gpm	768
	Velocity	fps	4
	Pipe diameter	inch	9
	Pipe length	ft	4,000 - 4,500
	Pipe material		PVC/HDPE
<b>Seawater Treatment Plant</b>			
	Plant product water capacity	gpm	307
	Plant product water capacity	gpd	442,080
<b>SWRO Treatment Plant</b>			
<b>Pretreatment - particulate removal</b>			
	Type		1 micron cartridge filter
	Number of cartage filters		3 (2+1)
	Capacity per cartridge filter	gpm	230
<b>Pretreatment - chemical pretreatment</b>			
	PH adjustment		Na(OH)/H2SO4
	Antiscalant		TI
<b>SWRO</b>			
	Number of SWRO Skids	#	2
	RO skid feed water flow rate per skid	gpm/skid	384
	SWRO skid configuration	-	Single pass/two stage
	Membrane elements	Size/type	8 inch/SWRO membrane
	Recovery	%	40
	Flux	gfd	8
	Capacity per skid	gpm	154
<b>Primary RO feed pumps</b>			
	Pump capacity	gpm	154
	TDH	psi	1000
	Drive	Type	VFD
	Horse power	HP	120
<b>Energy recovery</b>			
	ER Device	Type	Pressure exchange (PX) or work

**Table 3.2.4-4 Design Criteria**

Facility		Unit	Criteria
			exchange
	Efficiency	%	95
	RO Booster pump capacity	gpm	230
	RO Booster pump horsepower	hp	10
<b>Product water post treatment/stabilization</b>			
	PH and alkalinity adjustment		CO <sub>2</sub>
	Remineralization		CaCO <sub>3</sub> Contactor
<b>Disinfection</b>			
	Primary disinfectant		UV Light
	Virus inactivation and residual		NaOCl
<b>Concentrate Return</b>			
	Concentrate flow rate	gpm	461
		gpd	663,120
<b>Concentrate return pump station</b>			
	Pump TDH	ft	31
	Number of pumps	#	2
	Pump horsepower	HP	5
<b>Concentrate return pipeline</b>			
	Pipe flow velocity	fps	4
	Pipe diameter	inch	8
	Pipe length	ft	20,900
	Pipe material		PVC
<b>Product Water Pump Station</b>			
	Capacity	gpm	307
	TDH	ft	494
	Drive	Type	Constant speed
	Horse power		60
	Number of pump	#	2
	Pump	Type	Horizontal split case
<b>Product Water Pipeline</b>			
	Pipe flow rate	gpm	307
	Velocity	fps	3,48
	Pipe diameter	inch	6
	Pipe length, 16.5 miles	ft	87,120
	Pipe material		Steel/HDPE

### Source Water Intake

The subterranean seawater intake would be provided by construction of an HDD well. Specific technical data for the proposed intake structure are detailed in Table 3.2.4-4, above. As shown in Figure 3.2.4-2, the HDD well structure would be drilled below Dog Beach with an entrance pit east of PCH. The screened 200 ft. of the HDD well would be installed in deposits of the Toro Creek Paleochannel offshore and below the ocean floor.

### *Source Water Transmission*

The source water would be conveyed through an approximately one mile long ten inch diameter pipeline from the seawater intake to the new SWRO treatment plant. The pipeline would be laid out along Toro Creek Road (Figure 3.2.4-2)

### *Water Treatment*

Similar to the other SWRO projects described in this document, the SWRO treatment plant for this water supply concept would consist of: pretreatment to provide particulate removal and to prevent RO membrane scaling; seawater RO membrane skids with dedicated RO booster pumps and energy recovery devices, product water post treatment and stabilization and disinfection. Specific technical data for the proposed SWRO treatment are detailed in Table 3.2.4-4, above. For more detailed description of the SWRO treatment, read Water Treatment in previous Section 3.2.3.4 of this document.

### *Waste Stream System*

The water treatment waste stream (RO concentrate) is recommended to be returned into the ocean via existing cooling water return canal at Morro Bay power plant. The concentrate return pipeline would start from the new proposed SWRO plant, and would be laid out westerly along Toro Creek Road, southerly along PCH, and then it would turn westerly on Atascadero road to the point of connection with cooling water return canal at Morro Bay power plant.

### *Product Water Transmission and Connection to CCSD Distribution System*

The product water would be pumped from the product water pump station clear well at the SWRO treatment plant to the point of connection with CCSD's potable water distribution system. The length of the product water transmission pipeline is approximately 16.5 miles and pipe diameter is six (6) inches (Figure 3.2.4-1). The pipeline is proposed to be constructed along Toro Creek Road and PCH between the new SWRO treatment plant and Cambria. The product water pipeline would connect to the southern end of the CCSD's distribution system.

#### 3.2.4.5 Permitting Requirements

Implementation of this alternative would require obtaining permits from multiple permitting institutions including but not limited to:

- **CCC** - permitting would be required for consistency with coastal development plan since the entire project is within the Coastal Zone boundary.
- **RWQCB** - to address the potential impact of the new HDD subterranean seawater intake well.
- **CDPH** - to address source water and product water quality requirements and to approve the proposed water treatment processes.
- **Building Permits** – Grading and building permits may be required for the SWRO treatment plant.
- **City of Morro Bay/ Cayucos** – construction permits may be required for HDD well, treatment plant, and concentrate return.
- **Caltrans** – construction permits for construction along PCH in their ROW.



### 3.2.4.6 System Construction Requirements

Due to the small it's size, all SWRO treatment plant facilities can be installed in one single building.

The construction of HDD well utilizes “open hole” technology, which means that drilling fluid is required to hold the borehole open during drilling and construction. Drill pipe and downhole tools are used to advance the borehole, while drilling fluid is used to cool and lubricate the bit, stabilize the borehole, and carry cuttings (formation material) to the surface. Drilling of the borehole is generally achieved in two stages: drilling the small diameter pilot borehole, followed by enlarging the pilot borehole in one or more reaming passes to the diameter required to contain the casing, screen, and filter pack. Once the total lineal length and depth is reached, the pilot borehole is reamed by pushing and rotating the drill bit as it follows the pilot bore to its completion depth.

#### *Staging Location and Area*

Staging areas for the proposed SWRO treatment plant and HDD well drilling pit would be from surrounding open land as shown in Figure 3.2.4-2.

#### *Construction Accessibility*

Permanent and construction access for the SWRO treatment plant would be from Toro Creek Road off PCH. Access to the proposed SWRO treatment plant site would be provided for water trucks, cranes, equipment transportation trucks, and construction laborers. Adequate on-site parking during construction would be provided.

Construction access for the HDD well drilling pit would be from Toro Creek Road off PCH. The drilling work area and the equipment staging area would be surrounded by a temporary six ft. high chain link fence. Public access to the Dog Beach would not be affected during construction.

#### *Special Material and Equipment Requirements*

For the treatment plant, the UV equipment is proprietary and would need to be pre-selected or pre-purchased. Other equipment is readily available and will be part of the general contractor's scope of supply. Operation of the SWRO treatment plant would require transport and handling of chemicals at the plant site, including sodium hypochlorite, sulfuric acid, sodium hydroxide, antiscalant, carbon dioxide, and various cleaning solutions.

The HDD well screens would use 5/16-inch thick super duplex 2507 stainless steel materials with horizontal louvered openings. This stainless steel alloy will provide excellent corrosion resistance and prevent failure over the 25-year life of the project.

The treatment plant construction equipment would consists of standard commercial construction equipment, including, scrapers, graders, dozers, back hoes, vibrating compactors, loaders, cranes, forklifts, utility trucks, concrete trucks, and trailer mounted generators .

The HDD well construction equipment would consist of drilling equipment, gyroscopic steering device, temporary tanks, pumps, cranes, utility trucks, trailers and mounted generator.

Pipeline construction equipment would consist of standard pipeline construction equipment, including backhoes, vibrating compactors, loaders, cranes, utility trucks, and trailer mounted generators.

### Construction Duration

The proposed SWRO treatment plant, HDD seawater intake well, concentrate return piping, and source water and product water pipelines can be bid and constructed as a single project or as separate projects due to the differences in the types of contractors required. For a project of this size and magnitude, approximately a 16-18 month construction period is required assuming a typically five day per week schedule. Daily hours for construction activities would be limited by the County of SLO or City of Morro Bay construction permits, However, it is expected to be between 7:00 am and 4:00 pm. Construction of the different facilities can be ongoing at the same time. Construction must be completed of all facilities by the start of treatment plant testing.

#### 3.2.4.7 Engineering Cost Estimates

A planning level probable engineering cost estimates including capital and O&M costs have been prepared and summarized as follows. Detailed cost estimating backup information is provided in Appendix A.

### Construction Cost

Summary of the estimate probable construction costs is shown in Table 3.2.4-5. A construction contingency of 30 percent has been provided. An allowance of 25 percent of the construction cost was added for surveying, geotechnical investigation, engineering design, construction management, permitting and legal fees, and other CCSD administrative and staff expenses.

**Table 3.2.4-5 Conceptual Estimate of Probable Construction Costs**

Facility	Total
Subterranean Seawater Intake, HDD Well	\$2,952,000
Seawater Pipeline	\$600,000
SWRO Treatment Plant	\$4,708,000
Concentrate Return	\$2,628,000
Product Water Pump Station	\$1,250,000
Product Water Pipeline	\$7,841,000
Subtotal	\$19,979,000
Contingency (30%)	\$5,994,000
<b>Total Construction Cost</b>	<b>\$25,972,000</b>
Project Implementation Cost (25%)	\$6,493,000
<b>Total Capital Cost</b>	<b>\$32,465,000</b>

### O&M Cost

The cost of O&M would primarily occur at the SWRO plant for the Estero Bay Marine Terminal alternative. The conceptual O&M cost estimates are summarized in Table 3.2.4-6, assuming a six (6) month operation.

### Life Cycle Cost Analysis

The life cycle cost for the Estero Bay Marine Terminal HDD well alternative was analyzed and results are summarized in Table 3.2.4-7. The cost analysis used a cost of money of 3.5 percent for a period of 25 years.

**Table 3.2.4-6 Annual O&M Cost**

Costing Item	\$/Y (based on 6 Mo Operation)
Labor	\$75,000
Energy	\$194,000
Chemicals	\$25,000
Consumables	24,000
Total O&M Cost	\$318,000
Contingency (15%)	\$48,000
<b>Total Annual O&amp;M Cost</b>	<b>\$366,000</b>

**Table 3.2.4-7 Life Cycle Costs**

Facility	Total
Project Design Life, Year	25
Interest Rate	3.5%
Project Implementation Cost	\$32,465,000
Annual O&M Cost	\$366,000
Equivalent Uniform Annual Cost (EUAC)	\$2,336,000
Present Worth Life Cycle Cost	\$58,391,000
Future Cost of the Project	\$90,973,000
Cost of water, \$/AF	9,342

### 3.2.4.8 Summary of Benefits and Issues

The benefits and issues with implementing this alternative are provided as follows.

#### *Benefits*

- High reliability of water source,
- High quality of water,
- Use of proven technology and easy construction, and
- Minimal disturbance on marine life by HDD well.

#### *Issues*

The major potential issues facing this alternative include the following:

- Relatively high construction costs and O&M costs,
- Long pipelines in Caltrans ROW, and
- Permitting for HDD well and concentrate return.

### 3.2.5 Alternative Concept 5 - San Simeon Creek Road Brackish Water

Due to the complexity and not commonly used terminology in this section, a glossary of the terms used and an abstract are provided for this alternative concept. Both glossary and abstract are typed in italics.

#### ***Glossary of terms commonly used in this section and their definitions:***

***Aquifer*** – Portion of the San Simeon Creek basin from where ground water is extracted for the Cambria community water supply.

***AWTP waste stream*** – Stream of flows as side products of the AWTP process units including RO concentrate, used membrane filtration (MF) backwash water, neutralized RO and MF cleaning solutions, and instrument analyzer flow.

***Basin*** – The subsurface ground filled with alluvial deposits in the San Simeon Creek valley spreading inland from the ocean, and consisting mainly of gravels and sands.

***Brine*** – While the term BRINE may be more appropriate for the brackish water RO, and CONCENTRATE for seawater RO, BRINE and CONCENTRATE terms are used intermittently in this section.

***CDPH Log Credits*** – Logarithmic pathogen reduction credits granted by the CDPH for each unit process along the AWTP's treatment train that are counted towards the total number of logarithmic reduction credits required for indirect potable reuse.

***Seawater intrusion barrier*** – Hydraulic barrier created by water mound(s) that prevents seawater from entering the San Simeon Creek fresh water basin.

***Water Mound*** – Elevated ground water table caused by ground water recharge due to secondary effluent percolation, AWTP product water and brine injection.

#### ***Summary/Abstract of Alternative Concept 5 - San Simeon Creek Road Brackish Water***

*Under current conditions and without Warren property extraction, flows in excess of 286 AF of the San Simeon Creek water including percolated secondary effluent from CCSD's WWTP is lost in the ocean while maintaining fresh water mounds and preventing seawater intrusion. The San Simeon Creek Road Brackish Water alternative concept would extract from the basin, treat, and use a blend of the native basin fresh water, percolated secondary effluent, and as it may be necessary a deep aquifer brackish water to provide a new water supply to the Cambria community during six dry season months, to maintain fresh water in the creek downstream lagoons, and to improve the existing seawater intrusion barrier. The proposed San Simeon Creek Road Brackish Water alternative consists of existing percolation ponds, new brackish water extraction wells, new AWTP, two sets of new AWTP product water injection wells—one at the CCSD's potable water well field and the other at the San Simeon Creek lagoons, new AWTP generated brine disposal wells and piping system that would interconnect the proposed new and existing project facilities into a fully integrated water supply system. All the system proposed facilities, including extraction wells, AWTP, injection recharge wells and associated pipelines are located within the land area owned by CCSD.*

*The overall water flow mass balance for this alternative concept is presented in Table 3.2.5-A1 and the system schematic is presented in Figure 3.2.5-A1.*

**Table 3.2.5-A1 Dry Weather Season Flow Balance (AF/6 Dry Season Month)**

Basin Extraction and Recharge Activities		Current conditions w/o Warren Extraction	Current w/Warren extraction and 3,820 service connections	Proposed w/Warren extraction and 4,650 service connections (Scenario 1)	Proposed w/Warren extraction and 4,650 service connections (Scenario 2)
Ground water extraction out of San Simeon Creek basin	Cambria water supply <sup>(1)</sup>	370	370	370	370
	Warren Agreement - Warren property water use for irrigation during 6 dry month	0	184	118 <sup>(2)</sup>	184 <sup>(3)</sup>
	AWTP for new potable water supply and lagoons at plant 80% recovery	0	0	412	412
	New potable water supply - additional pumping from CCSD's San Simeon potable water well field	0	0	250	250
	<b>Total Extraction</b>	<b>370</b>	<b>554</b>	<b>1150</b>	<b>1,216</b>
Water recharge in San Simeon Creek basin	Water from basin storage available for extraction during 6 dry months <sup>(4)</sup>	>370	>370	>370	>370
	Water seepage in basin from deep irrigation at the Warren property	0	30 <sup>(5)</sup>	30 <sup>(5)</sup>	92 <sup>(6)</sup>
	Secondary effluent from CCSD's WWTP	286 <sup>(7)</sup>	286 <sup>(7)</sup>	348 <sup>(8)</sup>	282 <sup>(9)</sup>
	AWTP water recharge in potable water aquifer	0	0	250	250
	AWTP water lagoon recharge	0	0	80	80
	AWTP concentrate return in deep salty aquifer	0	0	80	80
	Brackish water extraction form deep aquifer	0	0	0	62
	<b>Total Recharge</b>	<b>656</b>	<b>686</b>	<b>1158</b>	<b>1158</b>
<b>Water Flow Balance</b>	<b>&gt;286<sup>(10)</sup></b>	<b>&gt;132<sup>(10)</sup></b>	<b>&gt;8<sup>(10)</sup></b>	<b>&gt;0<sup>(11)</sup></b>	

(1) Based on 1988 CCSD augmented diversion permit, 370 AF is the limit for CCSD pumping during 6 dry months from May 1 through October 31.

(2) It is assumed that 118 AF out of 184 AFY will be used by Warren avocado irrigation during 6 dry months from May 1 through October 31. This assumption is based on calculation that assumes 3 times avocado watering per month from March through October and once per month from November through February. (Irrigation: Avocados are tropical forest trees; they require frequent deep irrigation to produce quality fruit. They also grow year round, thus requiring a relatively consistent yearlong watering schedule. Avocado trees have evolved shallow roots that absorb nutrients & water quickly & efficiently. In most of Orange County, established avocado trees need watering two to three times a month (March through October). In the winter, water once a month only if rains fail. Avocados are sensitive to salts in the water (causes leaf tip burn) to remedy this irrigate deeply so that salts do not build up in the soil; compost mulch also works well to absorb these salts.)

(3) It is assumed that all 183.5 AF will be used by Warren property during 6 dry month period from May 1 through October 31.

(4) Assumed that the reoccurring basin water recharge will always be equal to, or larger than 370 AF extraction approved by the 1988 augmented diversion permit. This assumption is based on the 1998 USGS report, which reported that in 1988-1989, the basin inflow was 1,150 AF consisting of 50 AFY deep percolation from rainfall, 950 AFY seepage from San Simon and Gordon Creek channels during runoff, and 150 AFY basin inflows from adjacent areas. The 1988 and 1989 years were substantially dryer years with rainfalls 30 to 50% lower than long-term average.

(5) It is assumed that 20% to 30% of water used for irrigation at the Warren property will percolated back in the basin.

(6) Based on the 1998 USGS report (Table 6), it was assumed that 50% of the irrigated water will be returned in the basin.

(7) Based on daily average secondary effluent of 0.5048 MGD reported by CCSD's Quarterly Report for the Month of July 2013 and for the current 3,820 service connections.

(8) Prorated based on future 4,650 service connections.

(9) Secondary effluent flow from WWTP for percolation in the San Simeon Creek percolation ponds reduced by 66 AF that is planned by the 2004 Recycled Water Distribution System Master Plan to generate California Title 22 tertiary effluent for irrigation in Cambria.

(10) The flow balance is positive for both current conditions and proposed project. These excess flows will be discharged (drained) into the ocean, either as a creek open flows or subsurface basin discharge.

(11) San Simeon Creek flows in excess of 370 AF of native basin inflow will be discharged (lost) in the ocean.

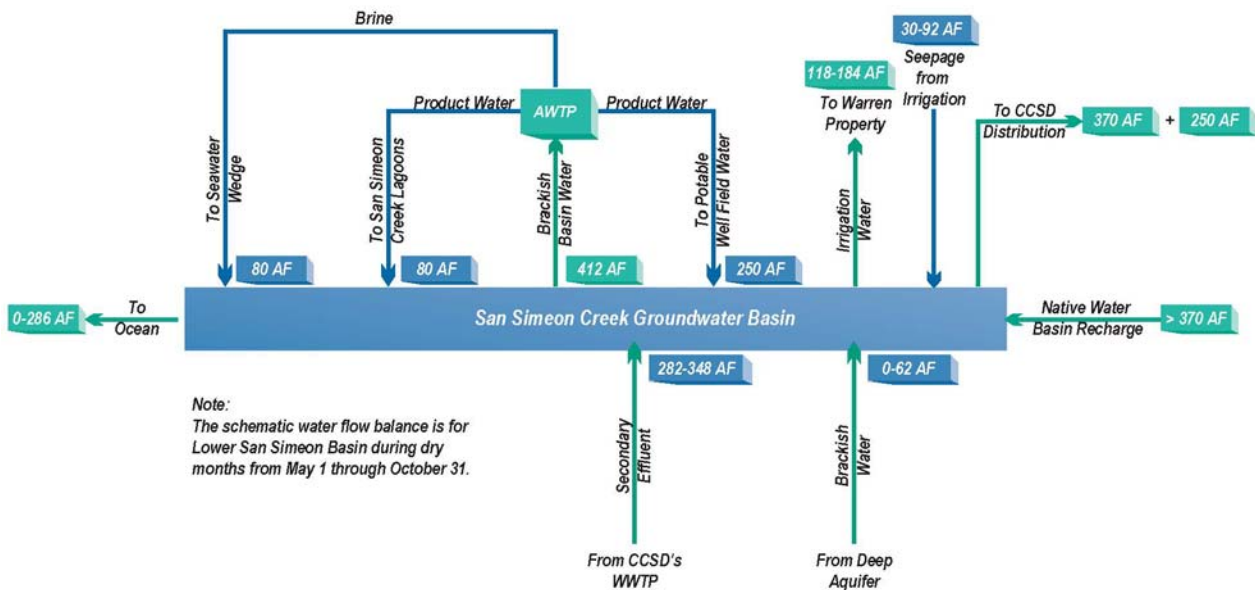

**Figure 3.2.5-A1 Alternative Concept 5 San Simeon Creek Road Brackish Water Dry Weather Season Water Flow Balance**

As it is shown in the Table 3.2.5-A1, under current condition and with 184 AF of water extraction for the Warren property, a flow in excess of 132 AF of basin water is lost as an ocean runoff flow during six dry month season. The proposed San Simeon Creek Road Brackish Water alternative would reduce the ocean runoff flow, and would generate a new 250 AF water supply for the Cambria community while providing San Simeon Creek downstream lagoons with 80 AF of high quality fresh water and improving efficiency of the seawater intrusion barrier.

### 3.2.5.1 Alternative Description

The San Simeon Creek Road Brackish Water alternative concept would provide additional potable water supply to Cambria community from the San Simeon Creek Basin, protect the San Simeon Creek fresh water lagoons and improve the current seawater intrusion barrier. The project would operate six months of the year during the dry weather season and manage the water level in the basin by controlling both the extraction from and recharge into the groundwater basin. Key project components are source of the project water, source water extraction, AWTP, potable water aquifer recharge, fresh water lagoon protection, AWTP generated brine disposal and seawater intrusion barrier. The project concept is graphically shown in Figures 3.2.5-1. More detailed description of the project and the project associated facilities is provided hereinafter in Section 3.2.5.4.

*Project Source Water* - The extracted groundwater that would feed to the AWTP (the project source water) would be a blend of the percolated secondary effluent from the CCSD's WWTP, fresh native basin groundwater and deep aquifer brackish water. This source water blend is referred herein to as brackish groundwater. Brackish groundwater would be extracted from the San Simeon Creek Basin, treated, and then injected back into the basin upstream and downstream of the existing CCSD potable well field, providing additional potable water supply to the Cambria community. The water elevation of the secondary effluent mound is higher than that of seawater, preventing it from moving inland when the inland basin water level is lower.

- Q1 - Secondary Effluent
- Q2 - Brackish Water Extraction to AWTF
- Q3 - Warren Property Water Allocation
- Q4 - Freshwater Lagoon Recharge
- Q5 - Concentrate Injection
- Q6 - Potable Water Aquifer Recharge
- Q7E - Potable Water Extraction - Existing
- Q7N - Potable Water Extraction - New
- QiR - Seepage Return Flow from Warren Property Irrigation
- Qp - Native Basin Water Recharge
- Qs - Water Flow / Loss to Ocean

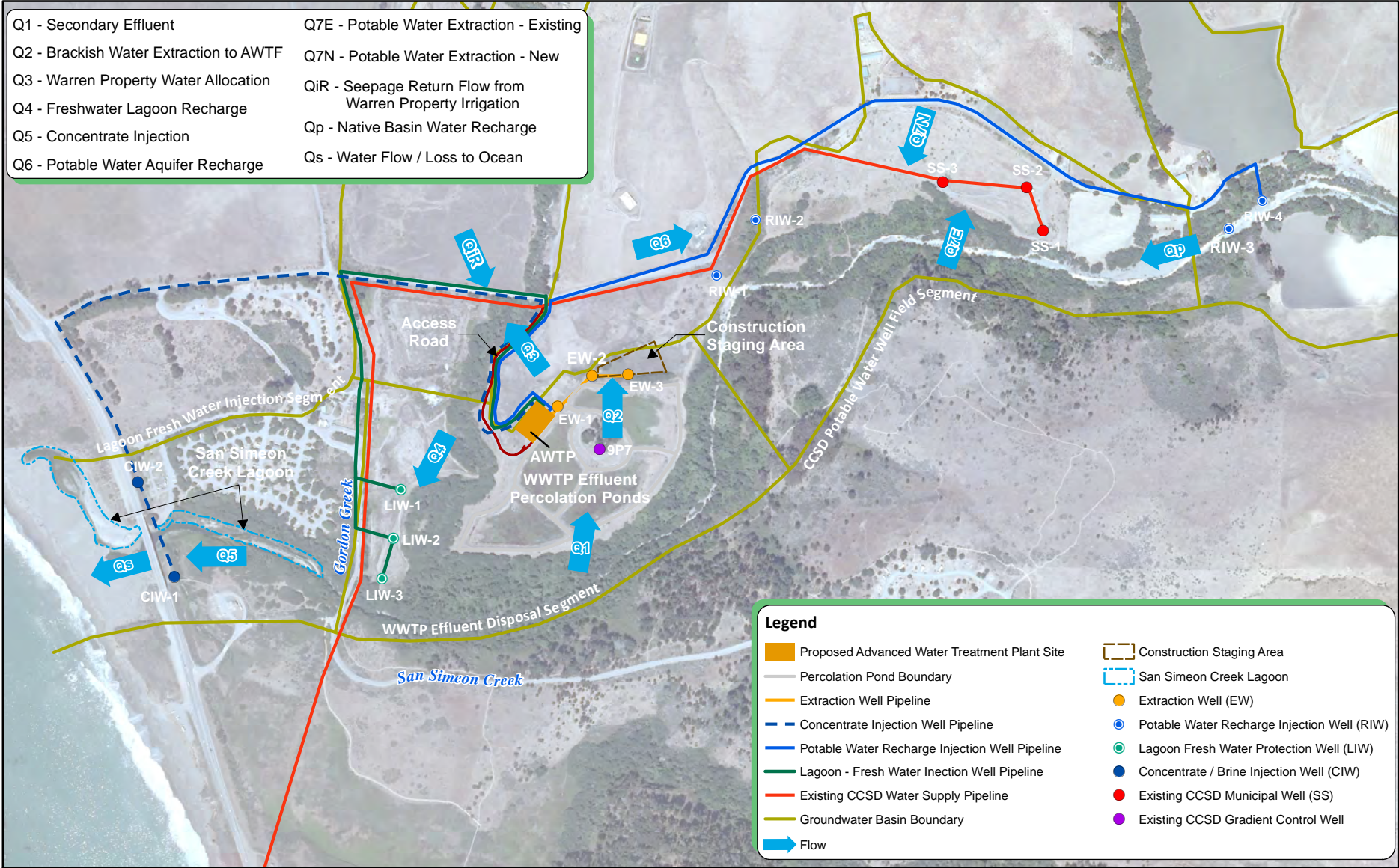

**Legend**

Proposed Advanced Water Treatment Plant Site	Construction Staging Area
Percolation Pond Boundary	San Simeon Creek Lagoon
Extraction Well Pipeline	Extraction Well (EW)
Concentrate Injection Well Pipeline	Potable Water Recharge Injection Well (RIW)
Potable Water Recharge Injection Well Pipeline	Lagoon Fresh Water Protection Well (LIW)
Lagoon - Fresh Water Injection Well Pipeline	Concentrate / Brine Injection Well (CIW)
Existing CCSD Water Supply Pipeline	Existing CCSD Municipal Well (SS)
Groundwater Basin Boundary	Existing CCSD Gradient Control Well
Flow	

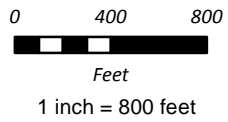

## Cambria Water Supply Technical Memorandum

**Figure 3.2.5-1**  
Alternative Concept 5  
San Simeon Creek Road Brackish Water  
Overall System Layout

*Source Water Extraction* - There would be three new brackish water extraction wells. The new proposed extraction wells would be located northwest of the percolation ponds and on their opposite side of the creek. This location of the extraction wells is selected with an objective to not intercept flow from percolation ponds into the creek at the times when the water table at the ponds is above the water level in the creek. The extraction well pumps would pump the brackish groundwater to the new AWTP for treatment.

*AWTP* - The new AWTP would be located just north of the existing secondary effluent percolation ponds and would consist of membrane filtration pretreatment, reverse osmosis, UV producing a hydrogen peroxide advance oxidation, and ancillary facilities. The product water capacity of the AWTP would be 330 AF produced during six dry season months. Assuming all process associated losses, the AWTP feed water flow rate would be 412 AF over the six months.

*Potable Water Aquifer Recharge* - There will be four potable water aquifer recharge wells – two located between the current secondary effluent percolation ponds and the current potable water wellfield, and two upstream of the potable water well-field. The proposed potable water recharge injection wells would recharge the potable water aquifer with 250 AF of the AWTP product water, which also would create a water mound between the existing secondary effluent percolation ponds and the potable water extraction wells. The AWTP product water mound would protect the well-field from percolated secondary effluent and allow for potable water extraction in addition to the native basin water recharge from San Simeon Creek.

*Potable Water Extraction Wells* - There are three existing water supply wells SS1, SS2 and SS3 that are extracting ground water from the San Simeon Creek potable water aquifer, each having capacity of 400 gpm. Since the combined flows of the new potable water of 307 gpm and existing CCSD's potable ground water pumping projections at built out conditions of 503 gpm (total to 810 gpm) is less than the capacity of the three existing wells (1,200 gpm), it is assumed that there would not be requirements for additional potable water supply wells at the San Simeon aquifer.

*Water for Lagoon Protection* - There would be three shallow injection wells that will inject 80 AF of the AWTP product water in the basin with an objective to provide the downstream San Simeon Creek lagoons with additional fresh water during dry season from May 1 through October 31. The new wells would be located just east of Gordon Creek and north of the San Simeon Creek in the land parcel owned by CCSD. The wells would be sized and designed so that all 80AF of the injected water will drain in the creeks and ultimately recharge in the downstream San Simeon Creek fresh water lagoons.

*AWTP Generated Concentrate* - There would be two wells for AWTP concentrate discharge into the seawater wedge, each about 150 ft. deep. The brine discharge wells would be located as close to the ocean as practical, which was determined to be east of PCH within the Caltrans ROW. Since the estimated brine salt concentration is approximately half an order of magnitude less than the salt concentration of the ocean water, the disposed brine alone will act as a seawater intrusion barrier that will slow down the seawater wedge inland advancement.

*Seawater Intrusion Barrier* - The current seawater intrusion barrier is formed by percolating secondary effluent at the existing secondary effluent percolation ponds. The San Simeon Creek Road Brackish Water alternative concept would further improve the current seawater intrusion barrier that keeps the seawater from moving inland and reduces the fresh water being lost to the ocean during the low flow periods in San Simeon Creek.



The proposed concept would form multiple water mounds starting from the seawater wedge at the ocean shore and going inland along San Simeon Creek all the way to upstream of the current secondary effluent percolation ponds (see Figure 3.2.5-2). The two brine injection wells and the lagoon freshwater injection wells will form two new water mounds that would supplement the existing seawater intrusion barrier formed by the percolated secondary effluent.

The mound formed by plant product water, between the percolation ponds and the potable water well field, will improve protection of the potable water aquifer against both seawater intrusion and secondary effluent from the percolation ponds.

### 3.2.5.2 Flows and Water Mass Balance

Flows into and out of the San Simeon Creek Source Water system are shown in Table 3.2.5-1, which lists the proposed facilities for each of the three groundwater basin segments shown in Figure 3.2.5-1 (Well Field Segment, Effluent Disposal Segment, and Lagoon Fresh Water Injection Segment). The number of operating days and AWTP on-line factor during those operating days is also shown in the table. The AWTP on-line factor is the percentage of the time that the plant operates over a period of time. For this analysis, an on-line factor of 90 percent for the project facilities is assumed, meaning that the project would operate 90 percent of the time during 184 dry season days each year. The project facilities are sized to meet the Table 3.2.5-1 flow rates on the basis of the above defined assumptions.

#### *Source Water*

The source water for the San Simeon Creek Road Source Water alternative concept is the brackish groundwater from the San Simeon Creek Basin. The water extraction out of the basin for the AWTP is labeled as flow Q2, shown in the reference Table 3.2.5-1 and Figure 3.2.5-1. Water flow into the San Simeon Creek basin includes basin recharge with more than 370 AF from San Simeon Creek (Qp), 348 AF of the secondary effluent (Q1) percolated into the aquifer through existing secondary effluent percolation ponds, and 30 AF deep basin water seepage from irrigation at the Warren property.

The Warren Extraction Allocation was defined by the agreement granting the Warren property the right to pump 182 AFY of untreated groundwater from the San Simeon Creek Basin (Q3) via well 9P7. This amount of water must be reserved for use by the Warren property and cannot be used by CCSD, even if the Warren property does not use their allocation. However, the Warren property allocation is included in Table 3.2.5-1 System Flows and Allocations as a part of the source water analysis to show that there will be sufficient flows of the percolated secondary effluent to meet the project requirements, while simultaneously providing the Warren property with 118 AF during dry season and an additional 64 AF during winter season from November 1 through April 30.

#### *Product Water Flow*

The product water flow from the AWTP is 330 AFY (406 gpm), which is the sum of flows Q4 - 80 AF for Lagoon Fresh Water Recharge, and Q6 - 250 AF for potable water supply - the flow that would be recharged in the San Simeon Creek potable water aquifer.

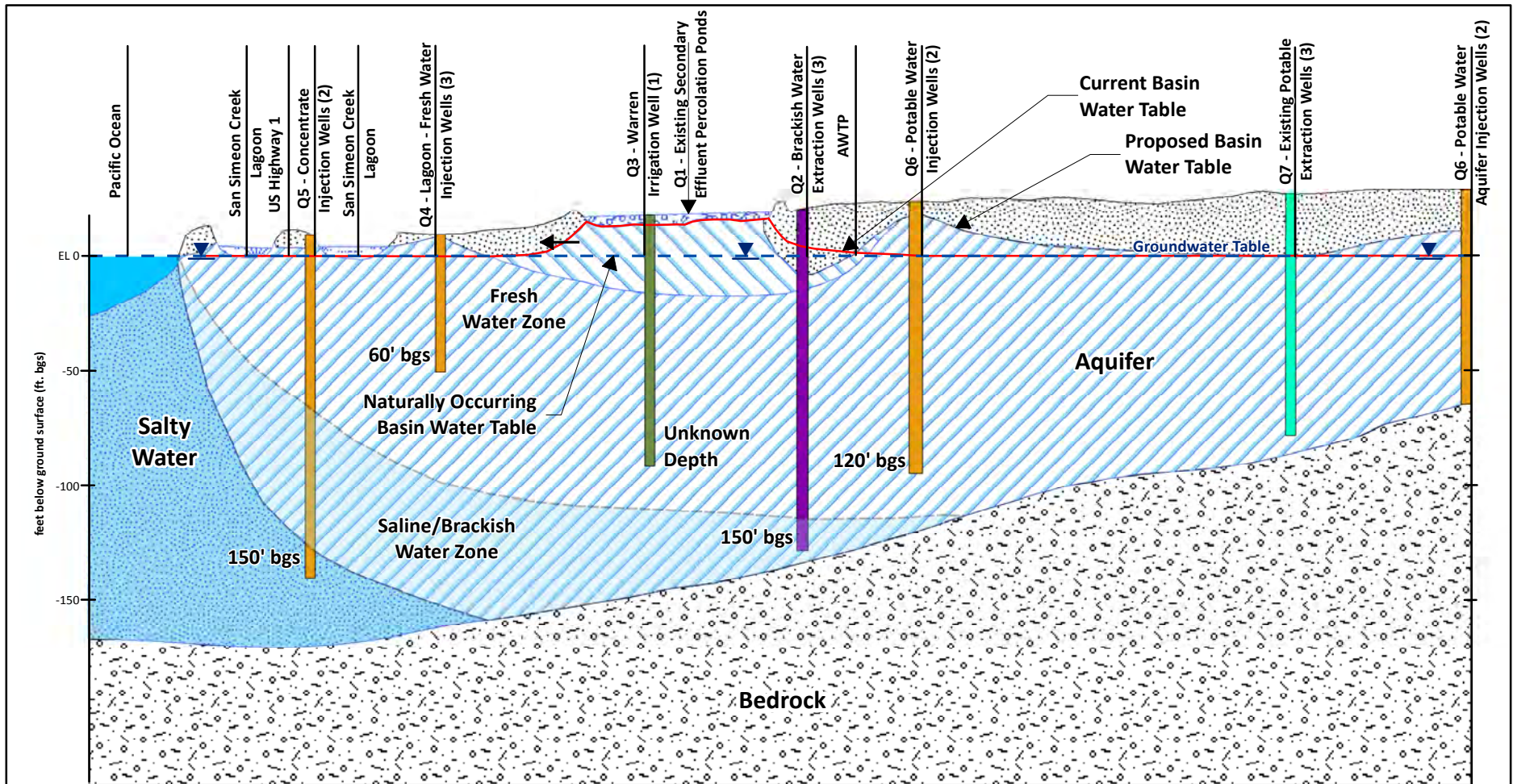

- Q1 - Secondary Effluent
- Q2 - Brackish Water Extraction to AWTF
- Q3 - Warren Property Water Allocation
- Q4 - Freshwater Lagoon Recharge
- Q5 - Brine Injection
- Q6 - Potable Water Aquifer Recharge
- Q7 - Potable Water Extraction
- Qp - Native Basin Water Recharge
- Qs - Water Flow / Loss to Ocean

**Legend**

- Groundwater Table
  - Current Water Basin Table
  - Injection Wells
  - Existing Potable Extraction Wells
  - Brackish Water Extraction Wells
- Warren Property Irrigation Wells
  - Ocean Water
  - Seawater Wedge
  - San Simeon Creek Lagoon
  - Bedrock
  - Ground Surface
- Saline / Brackish Water Zone
  - Percolation Pond Water Mound
  - Secondary Effluent Percolation Ponds
  - Bedrock
  - Ground Surface

Note:  
bgs: below ground surface

## Cambria Water Supply Technical Memorandum

**Figure 3.2.5-2**  
Alternative Concept 5  
San Simeon Creek Road  
Brackish Water Basin Cross Section

**Table 3.2.5-1 System Flows and Allocations (Built Out Conditions With 4,650 Service Connections)**

Flows and Allocations		Basin Flows*		
		Direction	gpm	AFY/6 Mo
<b>Lagoon Fresh Water Injection Segment (west)</b>				
Q4	Lagoon Fresh Water Recharge, AWTP Product Water	Into basin	98	80
Q5	Brine Injection from AWTP	Into basin	98	80
Qs	Basin Water Runoff into Ocean **	out of basin	>-0	>-0
	<b>Subtotal</b>		<b>&gt;196</b>	<b>&gt;160</b>
<b>WWTP Secondary Effluent Disposal Segment (center)</b>				
Q1	WWTP Secondary Effluent Recharge	Into basin	346	282
Q2	Extraction Allocation	out of basin	-505	-412
Q3	Warren Extraction Allocation	out of basin	-226	-184
Qir	Seepage in Basin from Warren property irrigation	Into basin	113	92
	Brackish Water from Deep Aquifer		76	62
	<b>Subtotal</b>		<b>-196</b>	<b>-160</b>
<b>CCSD's Potable Water Well Field Segment (east)</b>				
Qp	Native Aquifer Recharge*** (natural/summer)	Into basin	>454	>370
Q6	AWTP Potable Water Aquifer Recharge	Into basin	307	250
Q7-E	Existing Potable Water Extraction projection at built out condition**	out of basin	-454	-370
Q7-N	Potable Water Extraction (new)	out of basin	-307	-250
	<b>Subtotal</b>		<b>&gt;0</b>	<b>&gt;0</b>
<b>Total Basin Flow Balance</b>			<b>&gt;0</b>	<b>&gt;0</b>
	Online factor	90%	-	-
	Assumed AWTP yearly operating days	184	-	-
	Assumed Warren yearly operating days	184	-	-
Total AWTP Product Water Capacity			460	330

\* Flows are for the Warren Extraction and 4,650 Service Connections – Scenario 2, Table 3.2.5-A1

\*\* The flow balance assumes that the ocean run-off is always above “zero” during six month dry season

\*\*\* It is assumed that the native water aquifer recharge will be always equal to or larger than the existing potable water extraction allocation for dry season from May 1 through October 31.

### Waste Stream Water Flow

RO concentrate, used MF backwash water, and miscellaneous wastes consisting of neutralized RO and MF cleaning solutions and domestic sanitary wastewater are generated by AWTP. While the miscellaneous sanitary wastes would be discharged to an on-site septic tank or into the existing wastewater system at the State Park, three different options were considered for disposal of the AWTP treatment process generated brine stream including:

1. Subterranean ocean disposal using a HDD borehole from CCSD owned Flag Lot, which was constructed by Charington Corporation in 1994.
2. Open ocean disposal using the existing San Simeon WWTP outfall currently owned and operated by San Simenon CSD.

3. Subterranean disposal by recharging of the plant generated waste stream in the seawater wedge via deep injection brine injection wells.

Although Options 1 and 2 are technically feasible, Option 3 was selected for this project due to lower cost and beneficial use of the brine for basin protection against seawater intrusion.

The volume and flow rate of brine, the waste stream generated by AWTP as combined flows of the RO concentrate and used MF backwash water, is 80 AF or 98 gpm (see Section 3.2.5.4. for description of the project facilities and a detailed discussion of the waste streams). Since expected salt concentration in the waste stream is half an order of magnitude lower than salt concentration in the ocean water, the entire waste stream would be injected in the seawater wedge via brine injection wells to help in keeping the seawater wedge from progressing inland during the dry weather months. In Table 3.2.5-1, the major waste stream flows including used MF backwash and RO concentrate are annotated as Q5 flow.

#### *Other Water Flows*

Other water flows associated with this project are Qs (groundwater flows that leave the basin and drains into the ocean), and Qp (the San Simeon Creek native water that recharges the basin). The San Simeon Creek native water flow that recharges the groundwater basin is assumed to be always equal to or larger than 370 AF – the flow that was approved by the 1988 CCSD’s augmented diversion permit.

In the years of a prolonged drought when the basin native fresh water budget from the creek is low and Warren property pumps at maximum allowable rate of 184 AF over six dry months, the proposed alternative would pump up to 62 AF of deep aquifer brackish water to balance the projected water demands.

#### 3.2.5.3 Water Quality and Reliability

Water quality is provided in Table 3.5.2-2 for both the source water and the AWTP product water.

#### *Source Water Quality*

Groundwater would be pumped from the San Simeon Creek Basin from the proposed new extraction wells located near the existing secondary effluent percolation ponds currently operated by CCSD. The proposed extraction wells draw groundwater from the lower depths of the aquifer. Based on the information from the 1998 USGS study report, the expected source water quality would be a blend of the fresh basin groundwater, percolated secondary effluent, and deep aquifer brackish water. Ranges of the assumed source water quality data for the key water quality constituents, as well as the AWTP product water quality are shown in Table 3.2.5-2. If this alternative concept is selected for implementation, additional water quality sampling and hydro-geological modeling will be needed to complete its design.

**Table 3.2.5-2 Water Quality**

Water Quality Constituent	Source Water		AWTP Finished Product Water
	Average	Maximum	
Calcium, mg/L	77.5	120	10
Alkalinity, mg/L	328	500	20
Sulfate, mg/L	81.8	140	0.75
Chloride, mg/L	266	580	20
Total Nitrogen <sup>1</sup> (as N), mg/L	0.01	0.02	0.01
pH, units	7.8	8.3	8.5
Total Dissolved Solids, mg/L	862	1,380	50
Sodium (mg/L)	146	340	11
Iron (mg/L)	0.22	0.87	ND

### *Product Water*

The AWTP finished product water quality is also shown in Table 3.2.5-2. The AWTP product water that would be mixed with the natural groundwater after injection into the basin is soft and low in TDS concentration. The new AWTP would produce water that meets or exceeds the water quality of the current potable water supply.

Ultimately, the recharged AWTP product water would be extracted by the existing potable water wells. Changes to the existing basin water quality would need to be quantified through future hydro-geochemical modeling if this alternative concept is selected for implementation. It is expected that the new potable water from the basin would improve quality due to the influence of the injected water with lower hardness.

### *Water Supply Reliability*

The AWTP would be designed with redundant facilities (i.e. additional injection wells, pumps, etc.) that would allow the plant to operate at capacity for no less than 90 percent of the time, during the six months of planned operation. Because the AWTP product water is recharged into the groundwater basin, short periods when the plant is not operating due to power outage and regular maintenance would not impact the seawater intrusion barrier or aquifer ground water levels. A small amount of plant backup power would be required for emergency lighting and RO flush pumps to protect the membranes when the system is turned off. Also, the AWTP would be designed for an average daily capacity of 406 gpm which would be sufficient to provide 250 AF for water supply and 80 AF for the fresh water lagoons over 184 days during the dry weather season.

Because the source water for this alternative concept is a blend of fresh basin groundwater, percolated secondary effluent, and deep aquifer brackish water, it is assumed that the source water would be available during the dry months of the year 95 percent of the time. With the implementation of this alternative concept, along with the creation of an improved seawater barrier by injecting AWTP brine in the seawater wedge, the reliability of the San Simeon basin for the Cambria water supply would be increased.

### 3.2.5.4 Description of System Facilities

The San Simeon Creek Brackish Water alternative consists of extraction wells, a treatment plant, and recharge injection wells as shown in Figure 3.2.5-1, above. In this section, each of the alternative concept facilities is discussed in more details. The overall process flow diagram of the San Simeon Creek Road Brackish Water alternative concept is shown in Figure 3.2.5-3 and described in the following sections.

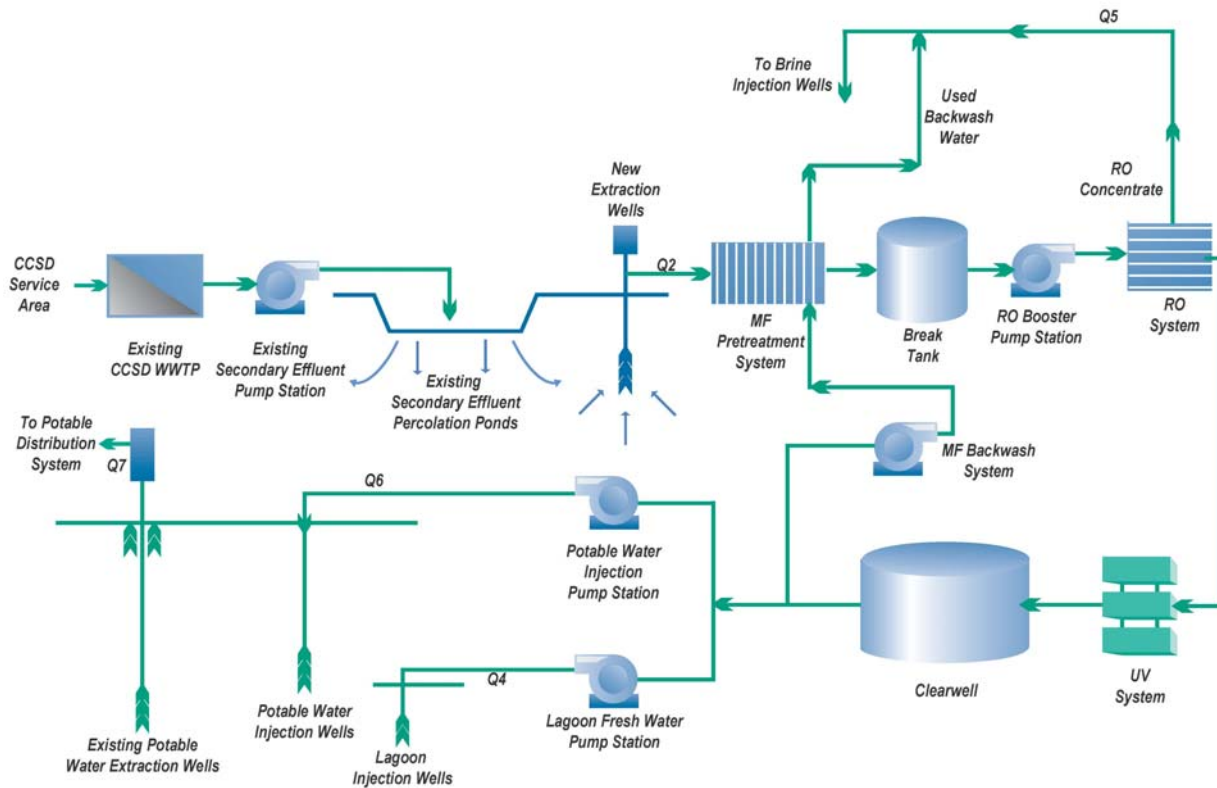

**Figure 3.2.5-3 San Simeon Creek Road Brackish Water Alternative Concept Process Flow Diagram**

#### System Design Criteria

Design criteria for each of the project’s major facilities, including the new extraction and injection recharge wells, and AWTP consisting of microfiltration, reverse osmosis, and UV advanced oxidation (AOX) systems, are provided in Table 3.2.5-3. There would be no modifications to the existing CCSD facilities, including the potable water wells or secondary effluent percolation ponds, anticipated at this time.

**Table 3.2.5-3 Design Criteria - Recharge Capacity 250 AFY**

Facility	Unit	Criteria
<b>AWTP Influent Facilities</b>		
<b>AWTP Extraction Well Facilities</b>		
AWTP Extraction Wells	Type	Vertical Wells
Total Well Extraction Capacity	gpm	510

**Table 3.2.5-3 Design Criteria - Recharge Capacity 250 AFY**

Facility		Unit	Criteria
	Number of wells (total)	#	3
	Redundancy	#	1
	Well diameter	inch	12
	Well depth	ft	120-140
	Well spacing	ft	200
	Well Production (ea)	gpm	255
<b>AWTP Extraction Wellhead Facilities</b>			
	Well pump TDH	ft	120
	Pump Efficiency	%	75
	Pump horsepower (ea) – average	HP	11
<b>AWTP Influent Pipeline</b>			
	Pipe flow rate	gpm	520
	Velocity	fps	2.1
	Pipe diameter	Inch	10
	Pipe length	Ft	650
	Pipe material		HDPE
<b>AWTP</b>			
	Influent to Plant	gpm	510
	MF Recovery	%	95
	RO Recovery	%	85
	Online Factor	%	90
	Plant product water capacity for Cambria water supply	gpm	307
	Plant product water capacity for fresh water lagoons	gpm	100
	Plant capacity for Warren property	gpm	0
	Total plant capacity	gpm	407
	Total plant capacity (Cambria)	MGD	0.60
	Total plant capacity (Warren)	MGD	0.00
	Total plant capacity	MGD	0.60
<b>MF Pretreatment - particulate removal</b>			
	Type		2 mm Automatic Backwashing Strainer
	Number of strainers	#	2
	Redundancy	#	1
	Capacity per strainer	gpm	420
<b>MF Pretreatment - chemical addition</b>			
	Chloramine Residual		NaOCl
	Chloramine Residual		Ammonia
<b>MF System</b>			
	MF/UF System Capacity	gpm	490
	Number of MF/UF Skids	#	2

**Table 3.2.5-3 Design Criteria - Recharge Capacity 250 AFY**

Facility		Unit	Criteria
	Redundancy	#	0
	Capacity per skid/feed flow rate	gpm	245
	MF/UF Skid configuration		pressure/outside in
	Membrane elements	gpm/module	14
	Membrane modules	Size/type	35
	Recovery	%	95
	Flux	gfd	35
<b>MF Break tank</b>			
	Number of tanks	#	2
	Storage	Minutes	30
	Volume (total)	Gal	15,000
	side height	Ft	16
	Diameter	Ft	13
	Type		Steel
<b>RO Transfer booster pumps</b>		<b>Type</b>	<b>Vertical turbine</b>
	Number of pumps	#	2
	Redundancy	#	1
	Pump capacity (ea)	Gpm	490
	TDH	Ft	50
	Drive	Type	VFD
	Efficiency	%	75
	Pump horsepower	HP	8
<b>RO Pretreatment - chemical addition</b>			
	PH adjustment		sulfuric acid
	Antiscalant		threshold inhibitor
<b>RO Pretreatment - particulate removal</b>			
	Type		1 micron cartridge filter
	Number of cartage filters		2
	Redundancy		0
	Capacity per cartridge filter	gpm	0
<b>RO System</b>			
	RO System Capacity (total)	gpm	420
	Number of RO Skids	#	2
	Redundancy	#	0
	Capacity per skid/feed flow rate	gpm	210
	RO Skid configuration		Two Stage
	Membrane elements	Size/type	8 inch RO membrane
	Recovery	%	85
	Flux	gfd	12



**Table 3.2.5-3 Design Criteria - Recharge Capacity 250 AFY**

Facility		Unit	Criteria
<b>RO Feed pumps</b>		<b>Type</b>	<b>Vertical turbine</b>
Number of RO Feed Pumps		#	2
Redundancy		#	0
Pump capacity		gpm	210
TDH		Ft	575
Efficiency		%	75
Drive		Type	VFD
Horse power		HP	40
<b>UV Advanced Oxidation System</b>			
UV System Capacity		gpm	420
Type			UV Light
Oxidation chemical			Hydrogen Peroxide
Number of UV Skids		#	2
Redundancy		#	0
Capacity per skid/feed flow rate		gpm	210
UV lights		Type	LPHO
Power		KW	74
<b>Product water post treatment/stabilization</b>			
PH			Sodium Hydroxide
Alkalinity adjustment			Calcium Chloride
<b>AWTP Lagoon Fresh Water Pump Station</b>			
Barrier PS capacity		gpm	100
Number of RO Booster Pumps		#	2
Redundancy		#	1
Drive		Type	VFD
PS TDH		Ft	70
Pump Efficiency		%	75
Pump horsepower		HP	2
<b>Recharge Pump Station</b>			
Barrier PS capacity		gpm	320
Number of RO Booster Pumps		#	2
Redundancy		#	1
Drive		Type	VFD
PS TDH		Ft	70
Pump Efficiency		%	75
Pump horsepower		HP	8
<b>Brine Pump Station</b>			
Brine PS capacity		gpm	100
Number of RO Booster Pumps		#	2

**Table 3.2.5-3 Design Criteria - Recharge Capacity 250 AFY**

Facility		Unit	Criteria
	Redundancy	#	1
	Drive	Type	VFD
	PS TDH	Ft	70
	Pump Efficiency	%	75
	Pump horsepower	HP	2
<b>Lagoon Fresh Water Barrier Facilities</b>			
<b>Lagoon Fresh Water Injection Wells</b>			
	Seawater Barrier Injection Wells	Type	Vertical Wells
	Number of wells	#	3
	Redundancy	#	1
	Well diameter	Inch	6
	Well depth	Ft	60
	Well spacing	Ft	200
	Well Injection (total)	gpm	100
	Well Injection (each well)	gpm	50
<b>Lagoon Fresh Water Wellhead Facilities</b>			
	Number of wells	#	3
	Pipe flow rate	gpm	100
	Velocity	Fps	2.6
	Pipe diameter	Inch	4
	Pipe material		steel pipe
<b>Lagoon Fresh Water Pipeline</b>			
	Pipe flow rate	gpm	100
	Velocity	Fps	2.6
	Pipe diameter	Inch	4
	Pipe length	Ft	3,900
	Pipe material		HDPE
<b>Recharge Facilities</b>			
<b>Potable Water Injection Wells</b>			
	Recharge Injection Wells	Type	Vertical Wells
	Number of wells	#	4
	Redundancy	#	1
	Well diameter	Inch	12
	Well depth	Ft	140
	Well spacing	Ft	400
	Well Injection (Cambria)	gpm	320
	Well Injection (Warren)	gpm	0
	Well Injection (total)	gpm	320
	Well Injection (each well)	gpm	320

**Table 3.2.5-3 Design Criteria - Recharge Capacity 250 AFY**

Facility		Unit	Criteria
<b>Wellhead Facilities</b>			
	Number of wells	#	4
	Pipe flow rate	gpm	320
	Velocity	fps	2.0
	Pipe diameter	Inch	8
	Pipe material		steel pipe
<b>Recharge Well Pipeline</b>			
	Pipe flow rate	gpm	320
	Velocity	fps	2.0
	Pipe diameter	Inch	8
	Pipe length	Ft	4,800
	Pipe material		HDPE
<b>Brine Disposal Facilities</b>			
<b>Injection Wells</b>			
	Brine Injection Wells	Type	Vertical Wells
	Number of wells	#	2
	Redundancy	#	1
	Well diameter	Inch	10
	Well depth	Ft	150
	Well spacing	Ft	500
	Well Injection (total)	gpm	100
	Well Injection (each well)	gpm	100
<b>Wellhead Facilities</b>			
	Number of wells	#	2
	Pipe flow rate	gpm	100
	Velocity	fps	1.1
	Pipe diameter	Inch	6
	Pipe material		steel pipe
<b>Injection Well Pipelines</b>			
	Pipe flow rate	gpm	100
	Velocity	fps	1.1
	Pipe diameter	Inch	6
	Pipe length	Ft	5,500
	Number of Pipes	#	2
	Pipe length	Ft	11,000
	Pipe material		HDPE

### *Source Water Intake*

Extraction wells are required to pump the source water out of the ground to the treatment plant. The location of the extraction wells is shown in Figure 3.2.5-1. Figure 3.2.5-2 shows a cross section of the San Simeon Creek Basin along with the approximate locations of each of the proposed facilities. If this alternative concept is selected for implementation, a detailed analysis of the interrelationship between the secondary effluent percolation, the brackish water extraction, the downstream San Simeon Creek lagoons, and the potable water recharge injection and extraction must be performed. Additional hydro-geological modeling is needed to confirm the estimated water balance, more precisely define number and locations of extraction and injection wells including well depth and diameter, identify possible basin hydro-geological improvements as it may be practical to increase basin storage volume, define system basin management requirements, and better define groundwater table and hydraulic grade lines.

The projected relative water levels in the aquifer are shown in Figure 3.2.5-2, with higher levels expected near the existing secondary effluent percolation ponds and at each of the injection well fields. Because of the secondary effluent percolation at the existing ponds, the groundwater level in that area is essentially the surface water level in the ponds themselves. The groundwater levels at the injection wells will be higher than in the adjacent areas because water is being added to the groundwater. In the same way, the groundwater level at the extraction wells will be lower because water is being removed from the basin.

Three brackish water extraction wells are located upstream of the existing secondary effluent percolation ponds as shown in Figure 3.2.5-1. The extraction wells would be designed to pull water out of various portions of the basin water, including the percolated secondary effluent, native basin water and the deeper brackish water. Based on the 1998 USGS report, there is no a distinct separation in salinity levels between fresh water and brackish water in the basin. However, salinity of the basin groundwater is higher at the deeper levels of the basin.

Materials of ground water well construction that resist corrosion of the brackish water would be needed to provide long term corrosion protection for the well facilities. The extraction wells would be sized to provide low yields as shown in Table 3.2.5-3. The above ground wellhead facilities include well pump motors, piping, flow meters, valves, and control panels (see Figure 3.2.5-4 for typical section and Figure 3.2.5-5 for wellhead of typical extraction well). The wellhead facilities could be housed in a building to mitigate noise or visual impacts, if required.

### *Source Water Transmission*

The water extracted by the wells adjacent to the existing secondary effluent basins would be pumped through proposed buried pipes to the proposed AWTP. The design criteria for the pipelines are provided in Table 3.2.5-3.

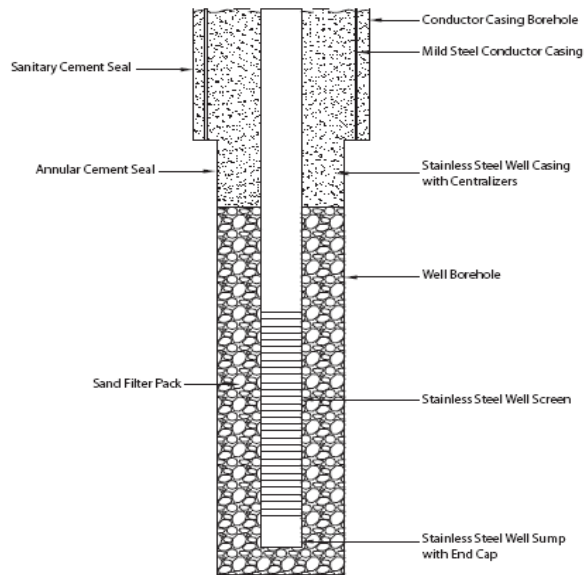

Figure 3.2.5-4 Typical Extraction Well Section



Figure 3.2.5-5 Wellhead of Typical Extraction Well

### Advance Water Treatment Plant Facilities

As shown in Figure 3.2.5-3, the main treatment processes include membrane filtration, RO and UV AOX process. Each of the processes is discussed below along with of the ancillary facilities.

*MF/UF* - In general, compared to other filtration technologies, including conventional granular media filtration, membrane filters (ultra-filtration or micro-filtration) with sub micron size pores produce the most consistent and reliable water quality with the lowest fouling potential when used in pretreatment for RO membranes. Membrane filtration will remove inert particulate material, suspended organic particulates, colloidal particulate materials, pathogenic organisms, bacteria and other particles to a level that will reduce the fouling rate of the RO system. Removal of dissolved salts, dissolved organics, constituents of emerging concern (CECs), TDS, silica, and viruses is accomplished by the proposed downstream processes including RO and UV AOX.

The proposed MF membranes for this alternative concept are polymer-based hollow fiber microfiltration or ultra-filtration membrane systems. These systems physically remove the particles from water based on size exclusion through pores on the surface of each membrane fiber. The water is driven through the pores by the pressure of the influent water, and it is collected on the other side of the membranes. The membranes have pore sizes in the range of 0.01 to 0.1 micron. Membrane fibers are contained in modules, typically mounted vertically in a skid arrangement.

Secondary treated wastewater is conveyed to the existing San Simeon Creek percolation ponds and percolated into the ground. The proposed extraction wells would pump the groundwater into the MF system to remove any particulates that are pulled out of the aquifer. Properly designed wells would minimize the solids. While membrane filters can come in submerged or pressurized configurations, pressure systems are the most commonly used and allow for the highest level of competition between multiple suppliers. The MF design criteria as assumed for the San Simeon Creek Road Source Water alternative concept are included in Table 3.2.5-3.

*RO* – RO is a physical separation process that uses a membrane to separate the solvent portion of a solution from the solute portion by applying pressure. It is effective at removing dissolved constituents that are not removed by MF pretreatment. The RO is the primary treatment system for

this alternative concept. RO systems remove dissolved organic constituents, minerals, bacteria, and viruses. It will remove over 90 percent of most nitrogen compounds, and greater than 98 percent of the TOC, TDS, metals, and most CECs. The RO used in this alternative would be similar to what is used in the seawater alternatives, except that the membranes allow for a slightly higher passage of salts and operate at significantly lower pressures. While groundwater would be the source water for this alternative, RO is considered the Best Available Technology for this type of treatment and has been used to treat groundwater for potable uses at numerous sites in California. It has also been used to treat secondary effluent for recharge purposes, including at the Orange County Water District, Water Replenishment District of Southern California, and other facilities in California. RO design criteria are included in Table 3.2.5-3.

*UV Disinfections and AOX* – The RO permeate would be fed directly to the UV unit process. This process uses UV light to disinfect the water by destroying the DNA of bacteria and viruses so they are not able to replicate. If hydrogen peroxide is added in combination with the UV light, hydroxyl radicals are generated (a process known as Advanced Oxidation) which are powerful oxidants that react rapidly with the constituents of emerging concerns, including trace organic compounds, pharmaceutical compounds, endocrine disruptors, and other CEC's, if any are present. While sometimes found in secondary wastewater, the above identified contaminants have not been identified in the San Simeon Creek aquifer. UV systems include pressurized stainless steel contactors with the UV lamps installed inside using low pressure/high output or medium pressure lamps. The proposed UV system design criteria are included in Table 3.2.5-3.

*Ancillary Facilities* - On-site ancillary facilities to support the major treatment processes are automatic backwashing strainers ahead of the MF, a break tank between the MF and RO systems to allow them to operate separately, cartridge filters to protect the RO membranes from suspended impurities, clean-in-place systems for the MF and RO, various chemical systems (sodium hypochlorite, sulfuric acid, antiscalant, sodium hydroxide, citric acid, calcium chloride). Hydrogen peroxide and sodium bi-sulfite will be required for UV AOX to enhance system water quality reliability.

*AWTP Site* – The location of the proposed AWTP is shown in Figure 3.2.5-1 and an enlarged schematic of the treatment plant layout is shown in Figure 3.2.5-6. Access is available from PCH via San Simeon Creek Road, which is currently used to access the existing secondary effluent percolation ponds. The treatment plant would be located south of San Simeon Creek Road and north of the percolation ponds. There would be one new process building onsite, with some of the ancillary facilities, like product water storage tanks, located outside. The MF, RO, and UV treatment process units will be enclosed in a building, along with the chemical systems, clean-in-place systems, and pump stations. Other facilities included in the building are a control room, an electrical room, a restroom and a storage room.

*Permanent Access* – The treatment plant would be constructed on CCSD owned property. Access would be from PCH via San Simeon Creek Road. A new paved access road approximately 2,000 ft. long and 20 ft. wide would connect the treatment plant site to San Simeon Creek Road. There would be five on-site parking spots provided for the operators and visitors. The plant would be manned during normal working hours and as needed to operate the plant and perform maintenance and repairs. New property or easements would be required to locate and operate the injection wells outside the CCSD owned property.



#### 4. Recycling and reuse of the used MF backwash water.

The used MF backwash water would be blended and discharged with the RO concentrate into the basin at the deep brackish water zone. If this flow cannot be permitted or sufficient sewer capacity is not available, the used MF backwash water can be recycled by returning it either to the head of the plant, or in the percolation ponds. Treating the used MF backwash water requires an inclined plate settler or dissolved air floatation (DAF) system to remove any solids, which should be minimal since the source of influent water for the treatment plant is naturally filtered groundwater. The effluent from the DAF or inclined plate settler could be routed to the head of the plant where it could be combined with source water fed to the treatment plant. The small amount of solids produced by the DAF or inclined plate settler can be discharged to the sewer or trucked off-site to the CCSD WWTP.

*RO Concentrate* - Brine produced by the RO system cannot be reused in the treatment process and must be discharged. Discharge options include:

1. Conveying the RO concentrate northward to the San Simeon CSD's WWTP and discharging to the ocean through the existing outfall. About 15 percent of the plant influent extracted from the aquifer would be lost from the basin with this option.
2. Rebuilding and use of the 1992 constructed bore hole originating at the CCSD owned Flag Lot that would provide for a subterranean brine disposal into the ocean. This option would require refurbishing and retesting of the existing borehole for brine disposal that would rely on discharge pressure generated by the RO brine pumps. About 15 percent of the plant influent extracted from the aquifer would be lost from the basin.
3. Injecting the RO Concentrate into the groundwater aquifer adjacent to the ocean where the water is already impacted by the seawater. Because the RO concentrate is injected in the basin, it is not lost and helps maintain the seawater barrier, keeping the seawater from infiltrating into the basin.

Injecting the AWTP brine (a blend of RO concentrate and used MF backwash water) into the groundwater basin is preferred option for this alternative concept. The RO concentrate injected into the seawater wedge near the coast would help support the lagoon fresh water barrier and eliminate water being diverted from the basin. If this alternative concept is selected, the effectiveness of the brine injection as a seawater wedge barrier should be more extensively defined in the follow up project implementation phases.

*Miscellaneous Wastes* – Miscellaneous wastes include neutralized clean-in-place solutions, instrumentation analyzer flows, rainwater collected in containment areas, domestic sewer flows from on-site rest room facilities, and other typical treatment waste flows. These flows would be discharged to an on-site septic tank, or the existing waste system at the State Park.

#### *Product Water Transmission and Connection to CCSD Distribution*

Pipelines would connect all of the off-site facilities with the AWTP, including the lagoon's fresh water injection wells that create a hydraulic mound to protect the lagoon, and the potable water recharge injection wells that provide water for the existing potable water extraction wells (see Figure 3.2.5-7 for wellhead of a typical injection well).





**Figure 3.2.5-7 Wellhead of Typical Injection Well**

### *Water Injection Wells*

This alternative concept includes two brine injection wells, three San Simeon Creek lagoon fresh water injection wells, and four potable water injection wells, each described as follows. A typical injection well design would be similar to the extraction well, but without well pumps because the water is injected into the ground by the force of the water pumps located at the AWTP site, see Figure 3.2.5-7.

*Brine Injection Wells* - The two (2) new brine injection wells would be located on east side of PCH, and are proposed to inject the AWTP generated brine in the basin as close to the ocean as possible. Due to lower TDS concentration of this brine (assumed to be in a range from 5,000 to 7,000 mg/L) compared to the seawater (approximately 35,000 mg/L), these injection wells could provide an advantage in slowing the inland advancement of the seawater wedge during the dry season when the AWTP is operational.

*San Simeon Creek Lagoon Fresh Water Injection Wells* - The three (3) new injection wells located west of the existing secondary effluent percolation ponds are proposed to provide the San Simeon Creek lagoons with fresh water year round, even when San Simeon Creek dries up during dry summer months. In addition, the lagoon's fresh water injection would suppress seawater intrusion as groundwater is pulled out of the basin to be purified at the AWTP. Since the San Simeon Creek Road Brackish Water system would only operate during the dry season months, a combination of the natural sand berm and injected water should reduce the amount of water flowing to the ocean, allowing more water to be captured and used.

*Potable Water Injection Wells* - There would be a total of four (4) potable water injection wells including two that would be located in between the existing potable water well field and the existing secondary effluent percolation ponds, and the other two located upstream of the existing potable water well field. This well arrangement is made with intent to provide two month in-ground retention of the injected AWTP product water, and to provide a water mound between the secondary effluent percolation ponds and the potable water well field.

### *Product Water Transmission and Connection to CCSD Distribution*

There is no need for modification to the existing potable water system facilities, including the San Simeon potable water well field extraction wells, identified at this time.

### 3.2.5.5 Permitting Requirements

This alternative concept includes multiple measures to protect the public health, including wastewater treatment, natural filtration of the percolated secondary effluent, membrane filtration, reverse osmosis, UV AOX and disinfection, and additional soil aquifer treatment of the recharged water prior to extraction by the potable water wells. The proposed AWTP uses proven treatment processes that are widely accepted as best available technology for water treatment. Similar water treatment processes are permitted elsewhere in California (Orange County Water District, Water Replenishment District of Southern California, West Basin Municipal Water District, Los Angeles County, California) for influent water with less prior treatment than is projected for the San Simeon Creek Road alternative concept. Anticipated permit requirements are provide below.

**RWQCB** – An operating permit for the San Simeon Creek Road system would be required from the Central Coast RWQCB. The RWQCB will have an interest in the impacts to the groundwater basin, and may require groundwater computer modeling to prove conformance with their requirements.

**CDPH** – The RWQCB permit will include significant input from the CDPH on safeguarding the public health. As noted above, the treatment plant utilizes multiple barriers to purify the groundwater. These multiple barriers are required because the source water for the treatment plant may be considered by regulators as being “under the influence of surface water” or of being of “wastewater origin” due to the proximity of the extraction wells to the existing secondary effluent percolation ponds. This alternative concept may or may not fall under the new CDPH draft Groundwater Recharge regulations. The concept has been developed to meet the new regulations, whether or not they are ultimately applied.

Since the groundwater will receive some natural filtration after percolation, the amount of credits required for the treatment plant will need to be negotiated with CDPH. While the MF system is a pre-treatment system for the RO, there are no specific regulatory requirements that are applicable to the MF, the RO, and the UV. However, the assumed process train, and the subsequent injection into the groundwater should provide adequate treatment credits to gain regulatory approval from CDPH. The plant would be designed to operate remotely, with operators on-site only during normal working hours, but CDPH will determine the ultimate staffing requirements for the plant.

**CCC** – All of the major project facilities are inside the coastal boundary and therefore would require a permit from the Coastal Commission.

**State Park** –Locations for the brine injection wells and lagoon fresh water injection wells would be within Caltrans ROW and CCSD property, respectively and as such outside of the California State Park property lines.

**Caltrans** – PCH is operated by Caltrans. The San Simeon Creek Road Source Water alternative concept has no pipelines or other facilities in the highway ROW. The only exception may be the concentrate injection wells, which need to be located close to the coast and could be located inside or adjacent to the Caltrans ROW. Obtaining a permit from Caltrans should be considered in the final siting of the concentrate injection wells.

**Building Permits** – Grading and building permits may be required for the treatment plant and well sites.

**Other** - Pilot testing is not required, but could be implemented to refine design criteria or to provide proof of operation for public outreach to the community.

### 3.2.5.6 System Construction Requirements

Construction of the San Simeon Creek Road water supply alternative would require multiple construction methods and would last between 14 to 18 months.

#### *Staging Locations and Areas*

All staging areas would be on CCSD owned land at the percolation pond area next to the assumed treatment plant site. The site plan for the treatment plant is shown in Figure 3.2.5-1 above. The staging locations for equipment, materials and construction worker parking would be on flat areas around the treatment plant process building. If needed a secondary construction staging area for potable waste injection wells may be on CCSD owned land at the existing potable water well field.

#### *Construction Access*

Construction access would follow the same alignment as the treatment plant's permanent access but would not be paved until treatment plant construction is complete. Access to the proposed treatment plant site would be required for grading equipment, water trucks, cranes, concrete trucks, equipment transportation trucks, and construction laborers. Adequate on-site parking during construction would be provided with construction trailer at the construction staging area, shown in Figure 3.2.5-1.

The open-trench construction approach for pipeline construction consists of site preparation, excavation and shoring, pipe installation and backfilling and restoration. Pipeline construction is expected to generally progress along the pipeline routes with the maximum length of open-trench at one time of approximately 80 to 100 linear ft. in length with a width of four ft. All trenches would be plated or filled in at the end of the day for safety. A temporary construction zone would have a width of approximately 25 ft. including space for trenching.

#### *Special Material and Equipment Requirements*

MF and UV are proprietary and would need to be pre-selected or pre-purchased. Other equipment is readily available and would be part of the general contractor's scope of supply. This project would require transport of chemicals to the site, including sulfuric acid, sodium hypochlorite, hydrogen peroxide, calcium chloride, sodium hydroxide, antiscalant, various cleaning solutions, and sodium bisulfite. The chemicals will be transported in permitted chemical trucks designed for safe chemical delivery.

*Treatment Plant Construction Equipment* - Construction equipment would consist of standard commercial construction equipment, including earth moving equipment, scrapers, graders, dozers, back hoes, vibrating compactors, loaders, cranes, forklifts, utility trucks, concrete trucks, and trailer mounted generators.

*Well Drilling Equipment* - The well drilling equipment would consist of standard well drilling equipment, including drilling equipment, temporary tanks, pumps, small cranes, utility trucks, and trailer mounted generators.

*Pipeline Construction Equipment* - Pipeline construction would consist of standard pipeline construction equipment, including backhoes, vibrating compactors, loaders, cranes, utility trucks, and trailer mounted generators.

### Construction Duration

The wells, pipelines, and treatment plant can be bid and constructed as a single project or separate projects due to the differences in the types of contractors required. For a project of this size and magnitude, approximately a 14 to 18 month construction period is required assuming a five day per week schedule. The treatment plant and pipelines can be constructed during normal working hours (7am - 4pm). Overall, assuming four weeks per well with well construction overlapping between wells, the total well drilling time would require approximately 6 to 8 months to complete. Well construction typically requires 24 hours per day construction for two weeks of the four week well construction period for each individual well. Construction of the different facilities (treatment plant, pipelines, and wells) can be concurrent. Construction of all facilities must be completed by the start of treatment plant testing.

### 3.2.5.7 Engineering Cost Estimates

A planning level engineering cost estimates including capital and operating costs were prepared and are summarized as follows. Detailed cost estimating backup information is provided in Appendix A.

### Construction Cost

Summary of the estimated probable construction cost is shown in Table 3.2.5-4. A construction contingency of 30 percent has been provided. An allowance of 25 percent of the construction cost titled "Project Implementation Cost" is also added for surveying, geotechnical investigation, engineering design, construction management, permitting, legal fees, and other administrative and staff construction expenses.

**Table 3.2.5-4 Conceptual Estimate of Probable Construction Cost**

Facility	Total
AWTP Water Extraction Facilities	\$955,500
Advanced Water Treatment Plant (AWTP)	\$4,519,620
Lagoon Fresh Water Barrier Facilities	\$708,000
Potable Water Supply Recharge Facilities	\$1,616,000
Concentrate Disposal Facilities	\$1,630,000
SUBTOTAL	\$9,429,000
Contingency (30%)	\$2,829,000
<b>Total Construction Cost</b>	<b>\$12,258,000</b>
Project implementation cost (25%)	\$3,064,000
<b>Total Capital Cost</b>	<b>\$15,322,000</b>

### O&M Cost

The AWTP can be designed to operate unmanned or with staffing on-site during regular working hours. Additional staffing may be required when the wells need routine maintenance and flushing. The AWTP will require operators with membrane experience. The conceptual O&M cost for the San Simeon Creek Road Source Water alternative concept is shown in Table 3.2.5-5.

**Table 3.2.5-5 Annual O&M Costs**

O&M Costing Item	\$/Y (based on 6 Mo Operation)
Labor	\$150,000
Power	\$113,753
Chemicals	\$20,684
Consumables	\$27,216
Maintenance*	\$21,773
Total O&M Cost	\$333,426
Contingency (15%)	\$50,014
<b>Total Annual O&amp;M Cost</b>	<b>\$383,440</b>

\* Includes cost to maintain facility when not in operation.

### *Life Cycle Cost Analysis*

Life cycle costs for the San Simeon Brackish Water Alternative Concept are shown in Table 3.2.5-6. For the life cycle cost analysis, 3.5 percent discounted interest rate and 25 years of project life cycle have been assumed.

**Table 3.2.5-6 Life Cycle Costs**

Criteria	Value
Project Design Life, Years	25
Interest Rate	3.5%
Project Implementation Cost	\$15,322,000
Annual O&M Cost	\$383,440
Equivalent Uniform Annual Cost EUAC	\$1,313,100
Present Worth Life Cycle Cost	\$32,828,000
Future Cost of the Project	\$51,145,000
Cost of water, \$/AF	5,252

### 3.2.5.8 Summary of Benefits and Issues

The benefits and issues associated with implementation of this alternative are provided as follows.

#### *Benefits*

For relevant criteria used for comparison with the other water supply alternative concepts, the benefits of the San Simeon Creek Brackish Water Treatment Alternative are summarized as follows.

- Low construction and O&M cost,
- Good quality product water,
- Reliable source of water supply,
- Proven technology,
- Existing potable water wells are used,
- Plant would be constructed on CCSD owned property, and
- The RWQCB, with CDPH approval, has permitted similar facilities.

*Issues*

- The AWTP product water will have different quality than is provided by the current water supply, which can be an issue due to lower hardness and salinity if proper mixing or conditioning is not carried out. Because the treated water is injected into the ground prior to extraction, there should be minimal impacts to the water quality delivered to the Cambria community, and an overall improvement in water quality is anticipated,
- This alternative concept would require computer modeling of the aquifer to show that the combination of extraction and injection wells would accomplish the goals and objectives laid out above,
- The waste disposal for the used MF backwash water and the RO concentrate must be investigated further to confirm that there are minimal or positive impacts to the aquifer and that the project can be permitted, and
- Public acceptance is critical for implementation of this alternative concept. Other recycled water projects in southern California 15 to 20 years ago had some issues with public acceptance. However, in the last 5 to 10 years, there have been numerous recycled water projects that have been accepted by the public with little, if any opposition. These facilities were constructed to treat secondary or tertiary water directly before injection into the ground, while this project would treat brackish groundwater under influence of secondary effluent, which is expected to be higher quality source water.

### 3.2.6 Alternative Concept 6 Hard Rock Water Storage and Recovery Alternative

#### 3.2.6.1 Alternative Description

The Hard Rock ASR concept would store ground water extracted during winter months from the Santa Rosa Creek basin into a confined Hard Rock Aquifer at Fiscalini Ranch located north of Highway 46, east of PCH and south of Santa Rosa Creek. The stored water would be recovered (extracted) from the Aquifer to provide an additional water supply of 250 AF to the Cambria community during the six month dry season.

Facilities proposed by this concept would involve the existing Santa Rosa Creek Well SR4 with wellhead iron and manganese treatment facilities and a new pipeline for water conveyance to the Hard Rock site for aquifer storage. The project would also need new injection and extraction wells as well as a new RO WTP to treat the stored water before its distribution. A product water pump station, and brine pump and disposal pipeline would be required for connection with the Cambria water distribution system and brine disposal site at Cambria WWTP (see Figure 3.2.6-1). All facilities in this concept would be located within the Coastal Zone Boundary, and on the land of Fiscalini Ranch Preserve.

During the wet weather season, water from Santa Rosa Creek Basin in excess to the water demand would be pumped, treated for iron and manganese removal, conveyed to and stored in the Hard Rock aquifer. During summer months, the stored water would be recovered from the aquifer, treated for ground water TDS removal using RO, disinfected and pumped back to the Cambria distribution system for potable use.

#### 3.2.6.2 Flows and Water Mass Balance

The design criteria for the Hard Rock ASR concept facilities, as well as descriptions of the system components, are provided in the subsequent sections. A summary of source water and product water flows is presented in Table 3.2.6-1.

**Table 3.2.6-1 Flows and Water Volumes**

Description	Units	Flows (Water Volume)
Product water	gpm (AF/6 Mo)	307 (250)
RO recovery	%	80
Well SR4 water and aquifer storage	gpm (AF/4 Mo)	589 (313)
Extraction from Aquifer	gpm (AF/6 Mo)	384 (313)
RO Permeate, product water	gpm (AF/6 Mo)	307 (250)
RO brine – water loss	gpm (AF/6 Mo)	77 (62.5)

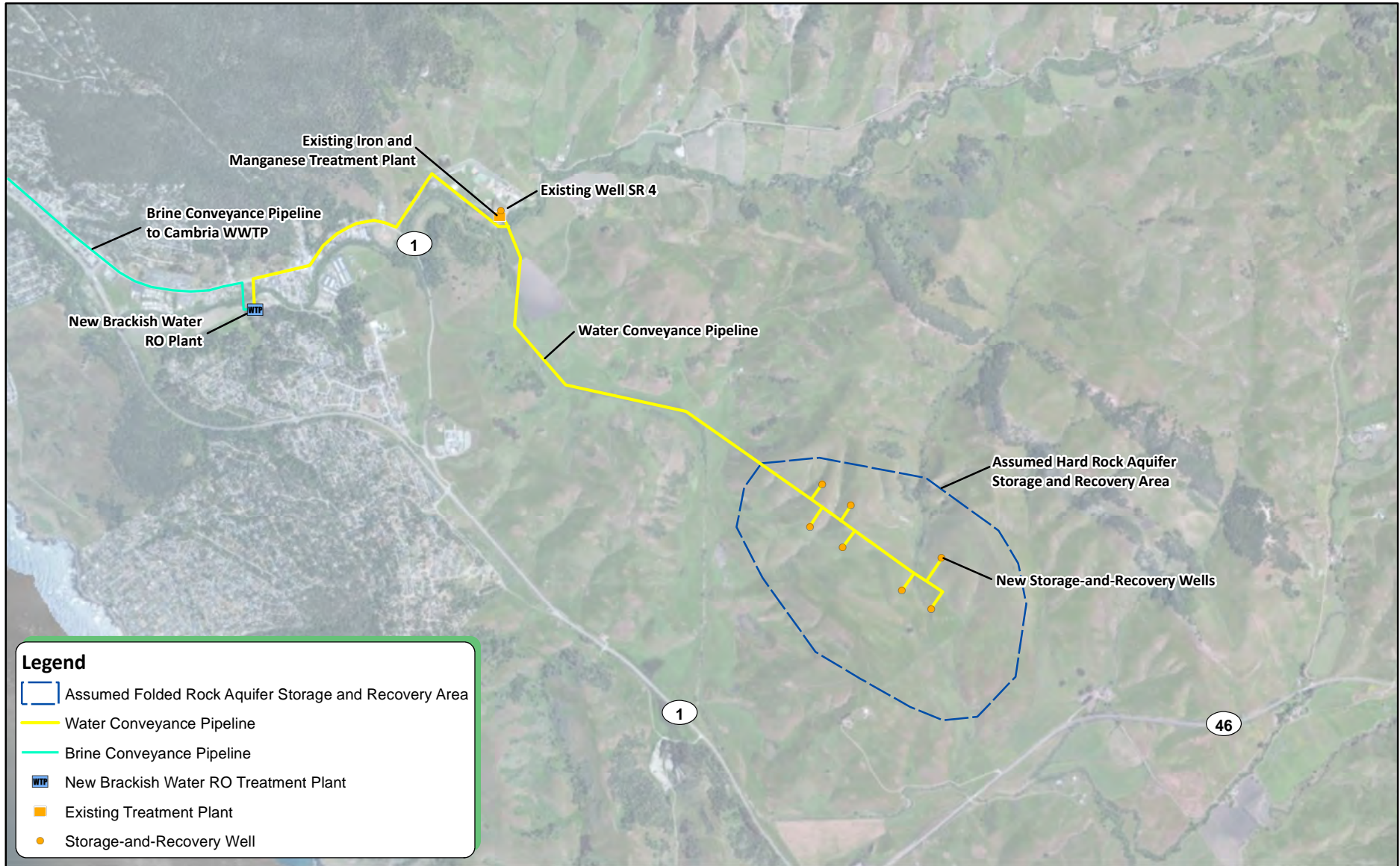

## Cambria Water Supply Technical Memorandum

**Figure 3.2.6-1**  
Alternative Concept 6  
Hard Rock Aquifer Storage and Recovery  
Overall System Layout



**CDM  
Smith**

0 1,500 3,000  
Feet  
1 inch = 3,000 feet



### Source Water

To provide the targeted 250 AF for dry season water supply for the Cambria community, and to account for losses, 313 AF of the water from the Santa Rosa basin would be required. The source water would be pumped from the basin at the rate of 589 gpm, which is the maximum pumping rate of the existing Well SR4 pump. To extract the targeted water volume, the Well SR4 would run at this rate for about 96 days during the wet season. The pumping rate and volume of the pumped water are within the limits set by the SWRCB appropriations permit, which limits extraction of water from the Santa Rosa basin to 518 AF annually and pumping rates to maximum of 1,120 gpm. The water would be pumped from the basin during the wet weather season when the water is available and pumped to the ASR injection wells for storage until the summer months when it would be extracted and used to supplement peak demands.

### Product Water Flow and Losses

It is assumed that about 20 percent of the water pumped from the basin would be lost before its delivery to the Cambria community. Some losses, up to 5 percent, are assumed to occur in the aquifer during storage, but the majority of the water losses would occur during treatment by the RO membranes proposed to remove salinity from the stored water. Depending on the levels of salinity and sparingly soluble salts in the recovered ground water, water losses at the treatment plant may vary, but for this project, it is assumed to be in range of 15 percent of the plant influent.

### 3.2.6.3 Water Quality

#### Source Water

The source water for the Santa Rosa Creek basin is characterized by moderate salinity, with the TDS within acceptable ranges for secondary water quality parameters. In addition, the Well SR4 water has elevated iron and manganese concentrations, which have been addressed by the recently installed greensand filters, manufactured by the PureFlow Company.

The new Hard Rock aquifer water storage-and-recovery wells would be deep wells. Since the low points in the aquifer are below ocean level, it is assumed that the water stored in the aquifer is extracted, it could potentially be degraded with an elevated salinity, which would require RO membranes for treatment to remove TDS down to the secondary water quality limits.

#### Product Water

The product water must meet all current potable water primary and secondary drinking water quality standards. Water quality goals and the regulatory limits for constituents of concern for this water supply concept are summarized in Table 3.2.6-2, below.

**Table 3.2.6-2 Product Water Quality Goals and Regulatory Limits**

Description	Units	Proposed Goals	Regulatory Limit
TDS	mg/L	<350	≤500
Turbidity	NTU	< 0.2	< 1
Hardness	mg/L as CaCO <sub>3</sub>	40-50	NA
pH	pH Unit	7-8	6.5 - 8.5
Free Chlorine Residual	mg/L	<1	<4

### 3.2.6.4 Description of the System Facilities

The Hard Rock ASR concept would consist of five major components including: (1) existing Well SR4 with the newly installed wellhead installed treatment system for iron and manganese removal, (2) pipeline for water conveyance to the Hard Rock aquifer site and back to the RO treatment site, (3) new injection-extraction wells, (4) new RO WTP and finished water pump station, and (5) brine pump and disposal pipeline.

#### Design Criteria

The design criteria for the proposed facilities are provided in Table 3.2.6-3. Descriptions of each of the system components are provided in the subsequent sections.

**Table 3.2.6-3 Design Criteria**

Facility	Unit	Criteria
<b>Water Supply</b>		
Water supply required over six dry months	AF	250
Water supply required over six dry months	gpm	307
Source of water		Santa Rosa Creek basin - Well SR4
Well SR4 pump capacity	gpm	589
Well extraction time at pump capacity of 589 gpm	day	96
Well pump horse power	HP	85
Well pump TDH	ft	373
Water treatment		Fe and Mg removal facility
SR 4 Year of construction		2001
<b>Water Conveyance Pipelines from SR4 to Hard Rock and from SR4 to RO Treatment Plant Site</b>		
Pipe flow rate	gpm	589
Velocity	fps	4
Pipe diameter	inch	8
Pipe length	ft	20,000
Pipe material		PVC/HDPE
<b>Aquifer Storage and Recovery Wells</b>		
<b>Storage/Recovery Wells</b>		
Water storage and recovery rates per well	gpm	14
Number of wells	#	42
Well diameter	inch	10
Well depth	ft	1000
Well spacing	ft	200 - 300
<b>Recovered Water Well Pump</b>		
Flow capacity per well	gpm	9
TDH	ft	1071
Pump horsepower	HP	8
<b>Water Treatment Plant</b>		
Plant capacity	gpm	307
Plant capacity	gpd	442,080
Plant feed water flow rate	gpm	384
<b>Process Train</b>		

**Table 3.2.6-3 Design Criteria**

Facility		Unit	Criteria
	Pretreatment		Cartage filters
	Chemical pretreatment		pH adjustment and-anti scalant
	Main treatment process		Brackish water RO
	Post treatment		Decarbonation, pH adjustment, stabilization
	Disinfection		UV and NaOCl for residual
<b>Product Water Pump Station</b>			
	Capacity	gpm	307
	Pump TDH	ft	228
	Pump horse power	HP	57
	Number of pumps	#	2
<b>Existing Well SR4 Pipe Connection to Distribution</b>			
<b>Brine Disposal</b>			
	Brine disposal flow rate	gpm	77
	Brine disposal approach		Cambria WWTP
<b>Brine Pipeline</b>			
	Size	inch	6
	Length	ft	5,000
<b>Brine Pump Station</b>			
	Capacity	gpm	77
	TDH	ft	10
	Brine pump horsepower	HP	1

### *Well SR4 and Wellhead Treatment Facility*

Well SR4 was constructed in 2001 and is furnished with a wellhead treatment facility for iron and manganese removal. Both well and wellhead treatment facilities would be rehabilitated for long term operations as the key components of this Hard Rock ASR project. The rehabilitated well pump would have enough head to pump the well water through the wellhead treatment equipment without breaking pressure to the storage-and-recovery wells at the Hard Rock Aquifer site.

### *Pipeline for Water Conveyance to the Hard Rock Aquifer Site*

Conveying the water between the SR4 and the Hard Rock aquifer water storage-and-recovery well would require an eight (8) inch diameter pipeline about 15,000 ft. long. As shown in Figure 3.2.6-1, the new water conveyance pipeline would be constructed along the local Ferrasci Road and in open space of the Hard Rock Aquifer area. The new pipeline would be constructed of high density polyethylene (HDPE) pipe material. The same conveyance pipeline used to transfer water from Well SR4 to the aquifer for storage during the wet season would be used to convey recovered water from the new WTP back to SR4 site. Additional recovered water pipeline would be constructed along Main Street between SR8 and the new proposed RO treatment plant site on the CCSD owned land property at Rodeo ground within the urban developed area of the Cambria community.

### *Water Storage-and-Recovery Wells*

A preliminary geotechnical surveillance conducted by DYA in June 2012 indicated a low conductivity of the aquifer deposits, and assessed that the capacity of storage-and-recovery wells at the Hard Rock Aquifer would be 14 gpm each. With this low yield, a large number of wells, estimated at 42, would be

required to inject and store 250 AF of water over 96 days during wet season. The new wells would be constructed to serve as injection (storage) wells at capacities of 14 gpm and as extraction (recovery) wells at capacities of only 9 gpm. Materials of construction for the new wells would be corrosion resistant stainless steel with a material grade that would resist corrosion to the potentially elevated brackish water salinity and chloride concentrations. The above ground wellhead facilities include recovery pump motors, piping, flow meters, valves, and controls. The wellhead facilities would be constructed in a building to mitigate noise and weather impacts.

#### *RO water treatment plant*

Based on a conservative assumption that the recovered water from the aquifer will be contaminated with elevated salinity concentration, desalination with brackish water RO membranes is recommended. Without a known recovered water quality, an 85 percent RO recovery is assumed for facility sizing and cost estimating purposes.

The new RO membrane treatment processes would include feed water pre-treatment, RO desalination, post treatment and stabilization, and disinfection. The pretreatment would consist of two (2) 5 micron cartridge filters to remove particulates, and chemical systems to adjust pH of RO feed water and to prevent membrane scaling. The chemicals that would be used include an inorganic (sulfuric or hydrochloric) acid to adjust pH and an antiscalant.

The RO membranes proposed to remove salinity from the recovered water would be brackish water low pressure RO membranes, similar to Dow Chemical's FILMTEC BW30-4040 membrane. Considering the treatment capacity of 307 gpm, two (2) RO skids are proposed, each with a 153.5 gpm capacity. Each of the two skids would be piped to operate as an independent process unit, and furnished with a dedicated RO booster pump, energy recovery device and control panel. The RO permeate would have a low TDS concentration and therefore would have a high corrosion potential. To stabilize the RO permeate and to get the desired final product water quality, post treatment consisting of decarbonation, pH adjustment, and addition of phosphates for water stabilization would be proposed.

UV light is assumed as the primary disinfectant, and NaOCl would be used to provide a chlorine residual in the distributed water. The proposed UV system includes two, on duty and one standby, in-line pressurized stainless steel UV contactors with the low pressure/high output UV lamps.

#### *Brine pump and disposal pipeline*

The proposed RO treatment will produce a high salt concentrated brine that will be pumped and conveyed for disposal at Cambria WWTP by a brine pipeline. Two (2) brine pumps, one duty and one standby, would be installed at the RO treatment plant. The proposed brine pipeline between the RO WTP and Cambria WWTP would be constructed along Main Street and Windsor Boulevard, and would end at the Cambria WWTP. At the WWTP, the brine would be blended and pumped with secondary effluent for disposal in the San Simeon Percolation Ponds.

#### *Ancillary Facilities*

On-site ancillary facilities to support the major treatment processes are clean-in-place systems for the RO membranes, various chemical storage and feed systems, power supply, and plant control system.

### *Treatment Plant Site and Access Road*

The proposed RO WTP would be located on a CCSD owned parcel at the Rodeo ground (see Figure 3.2.6-1). Access to the treatment plant would be off Main Street and along Burton Drive. Considering the small size of the treatment plant, it is assumed that all WTP facilities will be housed in one single building. The building would be constructed with architectural treatment that would blend the new structure with the surrounding houses.

### *Product Water Connection to CCSD Distribution*

Location of the new RO treatment plant within Cambria distribution network would allow low cost and easy to construct pipe connections in Main Street.

### 3.2.6.5 Permitting Requirements

Implementation of this alternative would require obtaining permits from multiple permitting institutions including but not limited to:

- **Land purchase/lease agreement** - with Fiscalini Ranch owner for land to install aquifer storage-recovery wells with associate pipelines and access roads.
- **CCC** - permitting would be required for consistency with costal development plan since the entire project is within the Coastal Zone boundary.
- **RWQCB** - would issue a permit to use Hard Rock aquifer for the ASR project and any changes in water quality to the percolation ponds.
- **CDPH** - would be required to address source water control and product water quality requirements and approve the proposed water treatment processes.
- **Building Permits** – Grading and building permits may be required for construction of new pipelines in the Cambria streets and roads.

### 3.2.6.6 System Construction Requirements

The conveyance pipeline between Well SR4 site and Hard Rock aquifer as well as the water storage-and-recovery wells would be constructed along local Ferassci Road and on the land currently belonging to Fiscalini Ranch. A portion of the water conveyance pipeline between Well SR4 site and new RO treatment plant site at Rodeo Ground as well as brine disposal pipeline would be constructed along Main Street. Preliminary field surveillance indicated that there are no geotechnical constraints for construction of the proposed facilities.

### *Staging Location and Area*

Staging areas for the proposed pipeline and RO WTP facilities would be within the CCSD owned land parcels at Well SR4 site and Rodeo Ground sites. Staging area for the aquifer water storage-and-recovery wells would be in an open space at the Fiscalini Ranch.

### *Construction Accessibility*

Access to the proposed construction sites would be required for grading equipment, water trucks, cranes, equipment transportation trucks, and construction laborers. Construction access for the new RO WTP would be from the Main Street and Burton Road in Cambria. Access to the aquifer water storage-and-recovery wells would be from local Ferassci Road on the Fiscalini Ranch land that would be further extended for this project. Adequate on-site parking during construction would be provided.

### *Special Material and Equipment Requirements*

For the proposed treatment plant, the required equipment is readily available and would be part of the general contractor's scope of supply. Operation of the existing Well SR4 facilities, new RO treatment plant, and new aquifer storage-and-recovery wells would require transport and handling of chemicals at the plant site including sulfuric or hydrochloric acid, antiscalant, sodium hydroxide and sodium hypo-chloride.

The treatment plant construction equipment would consist of standard commercial construction equipment, including earth moving equipment, scrapers, graders, dozers, back hoes, vibrating compactors, loaders, cranes, forklifts, utility trucks, concrete trucks, and trailer mounted generators.

Pipeline construction equipment would consist of standard pipeline construction equipment, including backhoes, vibrating compactors, loaders, cranes, utility trucks, and trailer mounted generators.

### *Construction Duration*

It is estimated that construction of the Hard Rock ASR water supply concept facilities would require 24 to 30 months. The longer construction time compared to some of the other alternatives is due to large number of the aquifer water storage-and-recovery wells and associated infrastructure including access roads and power supply lines that need to be constructed on a large undeveloped area.

### **3.2.6.7 Engineering Cost Estimates**

Construction cost estimates for The Hard Rock ASR concept include rehabilitation of the existing Well SR4 and the wellhead treatment facility, a water conveyance pipe, new injection-extraction wells, brackish water RO treatment plant, and brine pump and disposal pipeline. A planning level probable engineering cost estimates including capital and O&M costs have been prepared and summarized in the following sections. Detailed cost estimating backup information is provided in Appendix A.

### *Construction Cost*

The summary of estimated probable construction costs is shown in Table 3.2.6-4. A construction contingency of 30 percent has been provided. An allowance of 25 percent of the construction cost was added for surveying, geotechnical investigation, engineering design, construction management, permitting and legal fees, and other CCSD administrative and staff expenses.

### *O&M Cost*

The cost of O&M would primarily occur at the RO WTP for water recovered from the Hard Rock Aquifer. The conceptual estimates are summarized in Table 3.2.6-5, assuming a six month operation.

**Table 3.2.6-4 Conceptual Estimate of Probable Construction Costs**

Facility		Total
Well SR4 Refurbishment		\$112,000
Water Conveyance Pipeline SR4, Hard Rock, and RO Plant Site		\$2,327,000
Aquifer Storage and Recovery Wells		\$37,864,000
Recovered Water Well Pumping		\$2,671,000
Pump Station for Product Water Conveyance		\$454,000
Water Treatment Plant		\$2,210,000
Product Water Pump Station		\$454,000
Brine Pump Station		\$40,000
Brine Pipeline		\$600,000
Subtotal		\$46,279,000
	Contingency (30%)	\$13,884,000
<b>Total Construction Cost</b>		<b>\$60,163,000</b>
	Project Implementation Cost (25%)	\$15,040,000
<b>Total Capital Cost</b>		<b>\$75,204,000</b>

**Table 3.2.6-5 Annual O&M Cost**

Costing Item	\$/Y (based on 6 Mo Operation)
Labor	\$75,000
Energy	\$372,600
Chemicals	\$8,210
Consumables	\$16,100
Total O&M Cost	\$471,940
Contingency (15%)	\$70,790
<b>Total Annual O&amp;M Cost</b>	<b>\$542,730</b>

### Life Cycle Cost Analysis

The life cycle cost for the Hard Rock Aquifer Storage Recovery alternative was analyzed, and results are summarized in Table 3.2.6-6. The cost analysis used a cost of money of 3.5 percent for a period of 25 years.

**Table 3.2.6-6 Life Cycle Costs**

Facility	Total
Project Design Life, Year	25
Interest Rate	3.5%
Project Implementation Cost	\$75,204,000
Annual O&M Cost	\$542,730
Equivalent Uniform Annual Cost (EUAC)	\$5,105,700
Present Worth Life Cycle Cost	\$127,641,000
Future Cost of the Project	\$198,865,000
Cost of water, \$/AF	20,422

### 3.2.6.8 Summary of Benefits and Issues

#### *Benefits*

Major benefits of the Hard Rock ASR Alternative are as follows:

- Use of already appropriated water rights for source water from the Santa Rosa Creek basin,
- Use of existing or otherwise CCSD owned land and facilities,
- Proven technology and routine O&M practices, and
- All project facilities are in close vicinity to CCSD O&M staff.

#### *Issues*

Potential issues facing the Hard Rock Storage and Recovery alternative include:

- Land acquisition at privately owned Fiscalini Ranch,
- Large number of storage-and-recovery wells spread over a large, remote geographical area increases project construction cost and adds to complexity for O&M, and
- Limited data (including existing groundwater quality data), and possibly very low yield of the storage-and-recovery wells at Hard Rock Aquifer.



### 3.2.7 Alternative Concept 7 Whale Rock Reservoir

#### ***Glossary of terms commonly used in this section and their definitions:***

Due to the complexity and not commonly use terminology in this section, an abstract and a glossary of the terms used are provided for this alternative concept.

***Aquifer*** – Intermittently used with term basin – intended to have meaning of the portion of the San Simeon Creek basin or Santa Rosa Creek basin from which ground water is extracted for the Cambria community water supply.

***Basin*** – The subsurface ground filled with alluvial deposits in the San Simeon Creek or Santa Rosa Creek valley spreading inland from the ocean, and consisting mainly of gravels and sands.

***WTP waste stream*** – Stream of flows as side products of the WTP process units including used MF/UF and Granular Activated Carbon (GAC) backwash water, neutralized MF cleaning solutions, and instrument analyzed flow.

#### ***Summary/Abstract of Alternative Concept 7 - Whale Rock Reservoir***

*To increase water supply reliability for the Cambria community, groundwater from Santa Rosa and San Simeon Creek aquifers would be pumped for storage into the Whale Rock Reservoir during the wet season. The Whale Rock Reservoir would store raw water during wet seasons for its use as potable water supply to the Cambria community during the dry season. During the dry seasons, the stored water would be extracted from the Reservoir, treated, and conveyed back to Cambria as potable water supply.*

#### 3.2.7.1 Alternative Description

The Whale Rock Reservoir alternative concept would use the existing Reservoir near Cayucos for seasonal storage to provide an additional dry-season water supply of 250 AF to the Cambria community. The water stored in the Whale Rock Reservoir would come from the CCSD's annual diversion permit limit of 1,230 AF per year. Of this amount, approximately 313 AF (250 AF net flow for water supply plus 63 AF for losses) would be pumped during the winter season from the Santa Rosa Creek and San Simeon Creek aquifers into the Whale Rock Reservoir. To extract and convey groundwater to the Whale Rock Reservoir, the Whale Rock Reservoir alternative concept would require the existing Santa Rosa well SR 4, two (2) new wells at Santa Rosa basin and three (3) existing San Simeon Creek wells to operate at their full capacities for about 73 days during wet season. The water stored in the Whale Rock Reservoir would then be extracted, treated, and conveyed back to Cambria during the six dry –season months each year. This alternative concept would require a new pump station and a conveyance pipeline between Cambria and the Whale Rock Reservoir. A new WTP would also be built to treat the raw water from the Whale Rock Reservoir before delivering it to Cambria community water distribution system.

Most of the facilities of this concept would be located within the Coastal Zone Boundary, but outside of the limits of state parks and natural conservation areas. The key Whale Rock Reservoir concept facilities include all existing ground water wells, two new wells in Santa Rosa Basin, current water distribution system, new Cambria Pump Station, new water conveyance pipeline from Cambria to Whale Rock Reservoir, new surface WTP and new Whale Rock Pump Station. An overall layout of the Whale Rock Reservoir Alternative Concept is shown in Figure 3.2.7-1. Note that this figure does not show the existing well fields and Cambria Distribution System Network.



**Legend**

- Cambria - Whale Rock Reservoir Pump Station
- Existing Water Treatment Plant
- Proposed Water Treatment Plant
- Coastal Zone Boundary
- Water Transmission Pipeline
- Existing Raw Water Pipeline
- CCSD Water Discharge Pipeline
- Existing Reservoir Tank and Product Water Pump Station
- Proposed Reservoir Tank and Product Water Pump Station
- Water Transmission Pumps

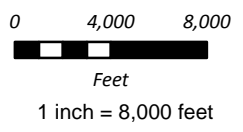

## Cambria Water Supply Technical Memorandum

**Figure 3.2.7-1**  
Alternative Concept 7  
Whale Rock Reservoir Overall System Layout



During the wet weather season, water from San Simeon Creek and Santa Rosa Creek Basins in excess to the CCSD water demand would be pumped and transferred from the existing Cambria water distribution piping system into a new Cambria Pump Station wet well located at the southeast tip of the Cambria community, see Figure 3.2.7-2. Extraction capacity of the existing three potable water wells SS-1, SS-2 and SS-3 is sufficient to extract and pump the groundwater from the San Simeon Creek basin to the Cambria Pump Station. In addition to the existing SR4, two additional extraction wells at the Santa Rosa Creek Basin would be required to capture the targeted excess flow. At the same time, it is assumed that the capacity of the Cambria water distribution system is sufficient to allow transfer of the targeted excess water simultaneously with regular water supply during wet weather seasons – an assumption subject to further investigation. Should the existing distribution system not be capable of conveying adequate flows to the new Cambria pump station proposed to be located west of PCH and southeast of Gleason Street, a new pipeline would be placed along Main Street from PCH to the intersection of Santa Rosa Creek Road and Main Street. A portion of the CCSD owned parcel west of this intersection would then serve as an alternate location of the pump station (See Figure 3.2.7-3).



Figure 3.2.7-2 Cambria Water Storage Reservoir and Pump Station



**Figure 3.2.7-3 Alternative Site Location for Cambria Pump Station and WTP**

The new Cambria Water Pump Station would consist of a 30,000 gallon wet well and two (one duty and one stand-by) pumps, each capable of pumping flow of 969 gpm. The new water conveyance pipeline would be installed along PCH in the Caltrans ROW. The ten inch diameter and approximately 16.5 mile long pipeline would be required to transfer the targeted water volume from Cambria to the Whale Rock Reservoir (see Figure 3.2.7-1) within 73 days. The new pipeline would be constructed of steel, HDPE, or a combination of both. Steel piping was assumed for cost estimating purposes.

The same transmission pipeline used to transfer water from Cambria to the Whale Rock Reservoir during the wet season for storage would be used to convey potable water from the new WTP to Cambria during the dry season.

The new WTP would be similar to the existing Cayucos WTP and consist of pre-chlorination, coagulation, filtration, filtered water polishing with GAC to address possible concerns regarding TOC, and taste and odor issues. Disinfected finished product water would be pumped to the Cambria distribution via a new product water pump station, pipeline and a new water storage reservoir. Used backwash and other treatment process produced wastewater will be recycled through a process consisting of a new inclined plate settler and sludge drying lagoons, which would eliminate offsite disposal of any plant generated liquid waste stream.

As shown in Figure 3.2.7-4, it is proposed that the new WTP to be located in Cayucos just northwest of the existing Cayucos WTP, which was driven by the initial idea to share the capacity of the existing plant. However, since additional capacity analysis showed that the Cayucos WTP may not have sufficient capacity to be shared with CCSD, a new WTP would be required for this alternative concept. Two alternative WTP site locations have also been identified in Cambria: alternative location 1 next to the proposed Cambria Pump Station and product water storage reservoir, which is shown in Figure 3.2.7-2, and alternative location 2 at the CCSD owned land parcel at the intersection of Santa Rosa Creek Road and Main Street, which is shown in Figure 3.2.7-3.



**Figure 3.2.7-4 Cambria Water Treatment Plant at Proposed Location in Cayucos**

### 3.2.7.2 Flows and Water Mass Balance

The water to be stored in the Whale Rock Reservoir would come from Santa Rosa Creek and San Simeon Creek aquifers. However, CCSD's permitted rights to pump water from the two creeks, storage capacity of the Whale Rock Reservoir and the frequency and duration of the available excess flows during the wet weather conditions were important factors when developing the Whale Rock Reservoir alternative concept.

#### *Permitted Water Pumping Rights and Reliable Supply Estimates*

Table 3.2.7-1 summarizes dry and wet season supply estimates for seasonal pumping of the CCSD San Simeon Creek and Santa Rosa Creek aquifers to and from the Whale Rock Reservoir. Reliability of the existing groundwater supply coupled with conditions within diversion permits issued by the SWRCB as well as a 1981 Coastal Commission-issued Coastal Development Permit, limit the CCSD's

pumping capabilities. The SWRCB permit limits the CCSD's dry season pumping out of the San Simeon Creek aquifer to no more than 370 AF between the time flow ceases at the Palmer Flats gauging station (which varies each year) and October 31. Permit conditions on dry season pumping from the Santa Rosa aquifer include limiting pumping to 260 AF from May 1st to October 31st. The CDP limits total annual pumping from both aquifers to no more than 1,230 AF.

**Table 3.2.7-1 Sources of Raw Water for CCSD's Whale Rock Reservoir Project**

	Unit	Annual	Dry season	Wet Season
San Simeon Creek Diversion Permit	AFY	1230	260	970
Santa Rosa Creek Diversion Permit	AFY	518	170	348
Total	AFY	1230*	430	1318*
Demand at built out conditions	AFY	910	534	376
Available for pumping in Whale Rock Reservoir	AFY	320*	(-104)	942*

\* The maximum annual aquifer production is limited to 1,230 AF by a 1981-issued Coastal Development permit, which is why 320 AF is shown as being available as opposed to 942 AF.

An earlier estimate of the CCSD's baseline supply included data showing the flow at the Palmer Flats gauging station had ceased with dates ranging as late as January 18, 1977, to as early as August 8, 1978, thus indicating that there could be considerable variability during which the permitted 370 AF pumping limit could apply. This same baseline study projected supply from the San Simeon aquifer under various modeling scenarios, including a partial recharge of the aquifer. The statistical analyses within this report indicated that approximately 260 AF would be available from the San Simeon aquifer more than 93 percent of the time. Therefore, for purposes of estimating the pumping needs and related costs for this alternative, a reduced value of 260 AF was assumed from the San Simeon aquifer as opposed to the permitted 370 AF dry season capacity. Dry season capacity for the Santa Rosa aquifer diversion was further reduced from its permitted capacity of 260 AF to 170 AF, which is further explained within the CCSD's 2010 Urban Water Management Plan Update as an estimated maximum to avoid potential subsidence. Therefore, for purposes of estimating pumping needs and facility costs, the dry season capacity shown for the Santa Rosa aquifer dry season production was assumed to be 170 AF as opposed to the permitted value of 260 AF. In addition to the aforementioned seasonal capacity limitations, the CCSD's diversion permits also limit the maximum pumping rate to no greater than 2.5 cfs from the San Simeon Creek aquifer and 2.67 cfs from the Santa Rosa Creek aquifer.

Based on the aforementioned estimates for production from each aquifer and the estimated demands at build out provided in the CCSD's 2010 Urban Water Management Plan, Table 3.2.7-1 shows the supply needed from the Whale Rock Reservoir to be approximately 104 AF during the summer dry season. The amount of water that could be supplied into the Whale Rock Reservoir during the wet season is estimated at 942 AF. However, this amount would be further limited by the 1981-issued CDP annual diversion limitation of 1,230 AF, thus lowering the amount estimated for pumping into the Whale Rock Reservoir to 320 AF. These amounts are annual supply estimates, and do not take into account a multiple year drought scenario, nor a widely varying seasonal rainfall and dry season durations, which can occur. Therefore, future Whale Rock Reservoir storage agreements should allow for an additional buffering supply beyond the 104 AF estimated in Table 3.2.7-1.

### *Rainfalls and Runoffs in San Simeon and Santa Rosa Creeks*

Stream flow in San Simeon and Santa Rosa Creeks is highly variable with rainfall as the predominant controlling factor. Yates and Konyenberg (1998) identified a close correlation between annual stream flow and annual rainfall depth ( $r = 0.96$  and  $0.91$  for San Simeon and Santa Rosa Creeks, respectively). Highly permeable surficial soils and limited groundwater storage capacity in the underlying basins minimize potential for increased basin storage that would be used to offset negative impacts of long-term trends in hydrologic conditions characterized by extended dry weather conditions. Consequently, flow in these creeks is largely a function of rainfall. Table 3.2.7-2 summarizes annual rainfall for Cambria and annual runoff based on data from recently monitored downstream SLO County stations (Stations 22 and 16).

**Table 3.2.7-2 Summary of Rainfall and Runoff Data from 1987 through 2004**

Variable	Minimum 1989-90 Water Year	Maximum 1994-95 Water Year
Rainfall (in/yr)*	9.98	44.31
San Simeon Creek Runoff (AFY)	595	22,879
Santa Rosa Creek Runoff (AFY)	515	50,142

\* Rainfall data was obtained from Cambria CFD Station, except for WY 1994-95 when this station was inoperable. Data from the Cal Poly SLO station was used for rainfall depth in WY 1994-95

### *Whale Rock Reservoir Storage Capacity*

For this report, the Whale Rock Reservoir storage capacity was estimated based upon the August 15, 2012 survey data provided by the City of SLO Utilities Department. A summary of this estimate as presented in Table 3.2.7-3 indicates that the Whale Rock Reservoir currently has enough capacity to store the additional 250 AF of water for Cambria water supply during dry weather season.

**Table 3.2.7-3 Whale Rock Reservoir's Current Capacity**

	Unit	Capacity
CCSD's Whale Rock Reservoir Project Water Capacity	AF	250
Total Reservoir Storage Volume	AF	40,662
Currently Stored Water Volume	AF	30,127
Currently Available Reservoir Volume	AF	10,535

### *Water Volume and Flows for Conveyance and Storage in Whale Rock Reservoir*

To establish water volume for conveyance and storage in the Whale Rock Reservoir, the projected additional water demand of 250 AF was increased to compensate for water losses during conveyance, treatment and evaporation. Table 3.2.7-4 summarizes required storage volume as well as storage and dry weather supply pumping rates.

The storage volume pumping rate of 969 gpm is established based on the data from TM "Support for In-Stream Flow Study on San Simeon and Santa Rosa Creeks (Appendix B) which estimated that there are 73 days each year when there will be sufficient inflow in the Santa Rosa and San Simeon Creek Basins to provide Cambria with regular wet weather water supply and needed excess water volume for conveyance and storage into the Whale Rock Reservoir.

**Table 3.2.7-4 Water Volume and Flows for Conveyance in Whale Rock Reservoir**

	Storage Volume AFY	Wet Season Storage Pumping Rate*, gpm	Dry Weather Supply Pumping Rate, gpm
Project Additional Water Demand	250	775	307
Conveyance and WTP Losses	12.5	39	NA
Reservoir Evaporation and Seepage	50	155	NA
Total Conveyance Volume	313	969	NA

\*Storage pumping rate is based on 73 pumping days

Assuming a 250 gpm capacity per each of the existing water supply wells, two(2) new additional well would be required in the Santa Rosa Creek Basin in order to provide the wet season storage pumping requirements.

#### *Well Production Capacity*

It is estimated that the combined capacity of the existing well SR4, two new wells in Santa Rosa Basin and existing wells at the San Simeon Basin would be sufficient to convey 313 AF during approximately 73 days of the wet season. The following Table 3.2.7-5 summarizes well capacities and pumping flow rates.

**Table 3.2.7-5 Required Pumping Capacity for Transfer to Whale Rock Reservoir**

Wet Season Pumping Duration	day	73
Required Pumping Flow Rate to Whale Rock Reservoir	gpm	969
Required Water Supply for Cambria During Wet Weather Season	gpm	460
Total required pumping for water supply and transfer into Whale Rock Reservoir	gpm	1,429
Capacity of 4 Existing and 2 New Wells in Santa Rosa Basin at 250 gpm/well	gpm	1,500

#### 3.2.7.3 Water Quality

Although the surface water from the Santa Rosa Creek and San Simeon Creek recharge the two creek groundwater basins, it is assumed that the quality of the water conveyed for storage into the Whale Rock Reservoir will be typical ground water extracted from these two basins. Therefore, the water from the San Simeon Creek basin would be disinfected potable water quality. The water from the Santa Rosa Creek basin would be also potable water. However it is assumed that the water from the Santa Rosa Creek basin will be treated for iron and manganese removal by the existing SR 4 Green Sand Filters.

The amount of San Simeon and Santa Rosa Creek water added to the Whale Rock Reservoir is expected to be a very small portion of the total volume currently stored. As result, the expected quality of the stored water that would be extracted and treated for water supply would be typical of the Whale Rock Reservoir water.

The following water quality Table 3.2.7-6 summarizes water quality of the water pumped from the basin, typical water quality of the Whale Rock Reservoir and MCL, or the targeted final product water quality.



**Table 3.2.7-6 Basin Water, Whale Rock Reservoir and Final Product Water Quality**

Water Quality Constituent	Unit	Basin Water for Reservoir storage <sup>1</sup>	Whale Rock Res. Water <sup>2</sup>	Product Water MCL
Hardness, as CaCO <sub>3</sub>	mg/L	452	272	<150
Sodium	mg/L	145	32	
Chloride	mg/L	266	24	150
Total Alkalinity as CaCO <sub>3</sub>	mg/L	-	233	10
TOC	mg/L	-	3.25	-
pH	Unit	7.8	8.14	9
Turbidity	NTU	1	6.1	0.2
Total Dissolved Solids	mg/L	862	367	700

1) 1998 USGS Report

2) San Luis Obispo CSA10-Cayucos, system No.4010025, 210 Watershed Sanitary Survey Update, County of San Luis Obispo

### 3.2.7.4 Description of System Facilities

The Whale Rock Reservoir system would consist of three key new facilities, including the Cambria storage reservoir and pump station, water conveyance pipeline, and new Cambria WTP. The existing potable water well SR 4, two new wells at Santa Rosa Basin, the three existing wells in the San Simeon Basin as well as the CCSD water distribution system will be integrated in the overall Whale Rock Reservoir system. The overall system diagram is shown in Figure 3.2.7-5.

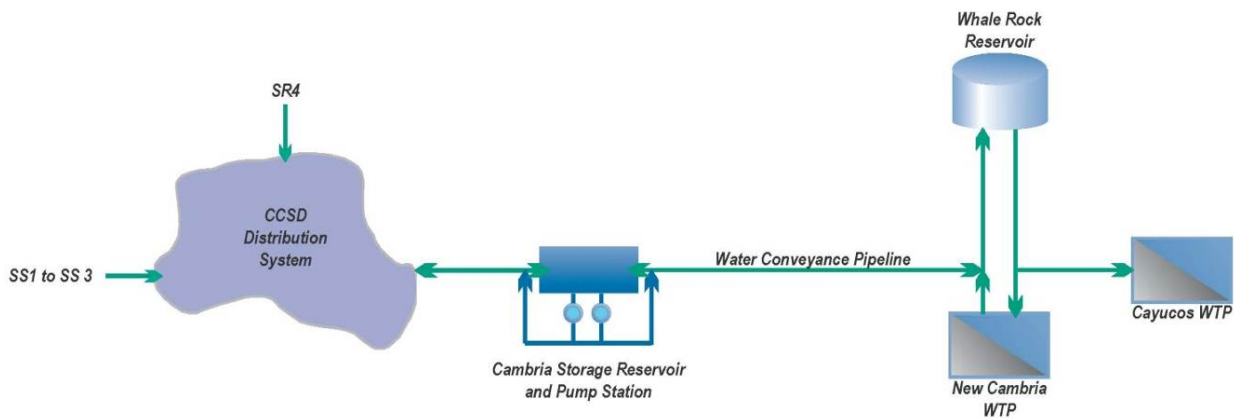
**Figure 3.2.7-5 Whale Rock Reservoir System Process Flow Diagram**

### System Design Criteria

Design criteria for each of the major new facilities, including Cambria source water pump station, source/product water conveyance pipeline, WTP and product water pump station are provided in the following Table 3.2.7-7. Description of each of the system components is provided in the subsequent sections.

**Table 3.2.7-7 Whale Rock Reservoir Alternative - Design Criteria**

Facility	Unit	Criteria
<b>Cambria Pump Station</b>		
Water pumping flow rate	gpm	969
Wet well volume	gallon	30,000
Pumping days	day	73
Pumping hours per day	h/day	24
TDH	ft	307
Pump horse power	HP	106
<b>Whale Rock-Cambria water conveyance pipeline</b>		
Pipe flow rate	gpm	314
Velocity	fps	0.8
Pipe diameter	inch	10
Pipe length	ft	87,120
Pipe material		Steel/HDPE
<b>Raw water pipeline along 13th Street - Diversion to Whale Rock Reservoir</b>		
Water pumping volume	AF	313
Water pumping flow rate	gpm	387
73 day water pumping flow rate	gpm	969
Velocity	fps	4
Pipe diameter	inch	10
Pipe length	ft	3,300
Pipe material		Steel/HDPE
<b>Surface Water Treatment Plant at Whale Rock Reservoir</b>		
Plant capacity	gpm	307
Plant capacity	gpd	442,000
Treatment process		Membrane UF/MF filtration
<b>Pretreatment</b>		
In-line pre-chlorination	mg/L	2
In-line coagulation, ferric chloride	mg/L	50
<b>Filtration</b>		
Filter type		MF/UF, pressured flow
Product		Skid Mounted
Capacity	gpm	157
Number of skids		2
Flux	gpdf	65
Transmembrane pressure	psi	25
Backwash frequency	h	24
Clean-in-place		Citric/sodium hypochlorite
<b>GAC Water Polishing Filters</b>		
Filter type		Pressure
Filtration rate	gpm/sf	10-15
Number of filters		2

**Table 3.2.7-7 Whale Rock Reservoir Alternative - Design Criteria**

Facility	Unit	Criteria
<b>Chlorine Contact Tank (CCT) and product water wet well</b>		
CCT resident time	min	45
Tank volume	gallon	14,130
Break tank type		bolted steel glass lined
<b>Disinfection</b>		
Disinfectant		12% sodium hypochlorite
Avg. dose	mg/l	2
Residual	mg/L	1
<b>Product water transfer pump station at Whale Rock WTP</b>		
Capacity	gpm	307
TDH	ft	257
Drive	Type	Constant speed
Horse power	HP	29
Number of pump	#	2(1+1)
Wet well	cf	5,000
<b>Product water storage reservoir (in Cambria)</b>		
Storage time	h	12
Storage volume	gallon	226,080
Storage tank type		Bolted steel glass lined

### *Source Water Intake System*

The source water, as referred in this document, is San Simeon Basin and Santa Rosa Basin ground water that would be extracted during wet season and pumped into the Whale Rock Reservoir for Cambria Community water supply during dry weather conditions. The groundwater intake will be provided by the existing groundwater well SR4 and two new groundwater wells located within the Santa Rosa Creek aquifer, and three existing potable water wells (i.e., SS-1, SS-2 and SS-3) at the San Simeon Creek aquifer. Water currently extracted from these wells provides the primary potable supply to the Cambria community. For this alternative concept, these wells will be producing flow to meet the Cambria community demand during wet weather conditions plus an additional flow of 969 gpm that would be conveyed and stored in the Whale Rock Reservoir. It is assumed that there would be no changes and/or modifications of the existing well facilities including the existing Green Sand Filtration system at SR4 that would be required for this project.

### *Source Water Conveyance System*

Key facilities of the source water conveyance system include the existing Cambria water distribution piping system, Cambria Pump Station, and water conveyance pipeline.

*Cambria Water Distribution Piping System* - The source water produced from the Santa Rosa and San Simeon Creek basins would be conveyed to the Cambria Pump Station through the existing CCSD water distribution network. It is assumed that the existing piping system will have enough capacity to provide regular water supply to the Cambria community plus the additional flow of 969 gpm for conveyance to Whale Rock Reservoir without any new improvements to the piping system. However, if this alternative concept is selected for implementation, this assumption will be revisited and proved at the further project development phases.

*Cambria Pump Station* – As shown in Figure 3.2.7-1 and Figure 3.2.7-2, the new Cambria Pump Station would be located at the south east tip of the Cambria community west of PCH and south of Gleason Street. To account for unknowns associated with the distribution system capacity, an alternative site is also shown west of the intersection of Santa Rosa Creek Road and Main Street in Cambria (see Figure 3.2.7-4). The new pump station will occupy a 0.5 acre lot and will have a 30,000 gallon wet well and two pumps, one duty and one standby.

*Water Conveyance Pipeline* - A new ten (10) inch diameter and approximately 16.5 mile long pipeline would be required to convey the targeted water volume of 313 AFY to the Whale Rock Reservoir at rate of 969 gpm for 73 days during the winter wet season. The same pipeline would be used to pump 250 AF of the treated water back to Cambria at rate of 307 gpm for 184 days during summer dry season. The proposed water conveyance pipeline alignment is along PCH within Caltrans ROW and extends from Cambria Pump Station to Cayucos. In Cayucos, the pipe alignment turns northeasterly towards Whale Rock Reservoir and along 13th Street.

A field reconnaissance indicated an approximately 200 ft. elevation change along the initially considered alignments. However, the alignment along the PCH roadway is within geotechnically stable soil formations crossing areas with serpentine rocks north of Cayucos and is proposed as part of this alternative. In addition, at a number of places, the considered alignment is crossing bedrock, creeks and several road cuts without sufficient soft shoulder space to layout pipeline. Detailed design efforts would further consider whether certain pipeline segments could be suspended under existing bridges or possibly employ horizontal direction drilling installation methods.

The pipe material candidates for this application include steel, HDPE, or a combination of both. Although final piping material selection will be made in the following phases of the project development, steel pipes are assumed for this document.

#### *Water Treatment Plant*

The new Cambria WTP would be sized for a product water capacity of 307 gpm and would run for six months during dry summer season. It is assumed that the Cambria community peak day demand would be provided by the existing groundwater wells. As shown in Figure 3.2.7-6, the main treatment processes of the new WTP include chemical pre-treatment, membrane filtration, filtrate break tank and intermediate pump station, GAC water polishing filters, CCT and product water pump station.

For the purpose of this report, it is assumed that the new Cambria WTP would be located in Cayucos just north of the existing Cayucos WTP.

*Chemical Pre-Treatment* – It is expected that the chemical pretreatment w be deployed only occasionally during events of elevated turbidity and algae contents in the WTP influent water. Pre-chlorination and coagulation with ferric chloride as a coagulant are assumed as the only pre-treatment processes for the new WTP. Principal objectives of the proposed pretreatment are to destabilize colloidal solids and to control algae in the source water before filtration.

*Filtration* – MF/UF is assumed as the main treatment process for the new Cambria WTP. With sub micron size pores, the assumed MF/UF produces superior product water quality compared to conventional granular media filtration. In addition, the MF/UF requires minimum pretreatment and occupies minimal space for the facility siting. It provides for reliable removal of inorganic and organic suspended solids, colloidal particulate materials, pathogenic organisms, bacteria and other particles from surface waters.

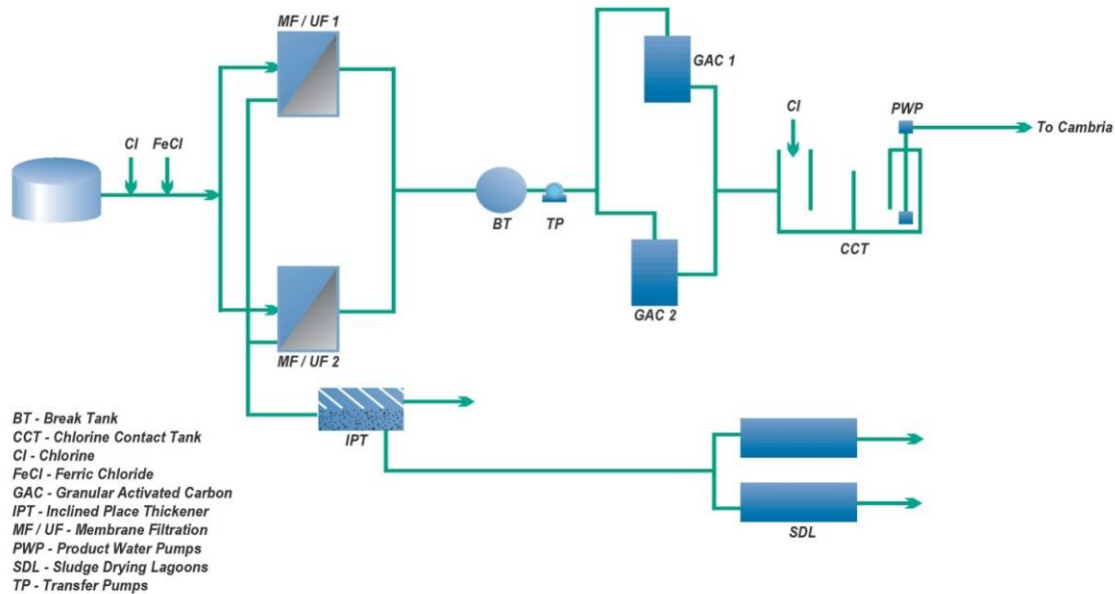

**Figure 3.2.7-6 Cambria WTP Process Flow Diagram**

The assumed MF/UF consists of hollow tube membrane bundles packed in membrane modules and installed on two MF/UF skids. For the purpose of costing and facility siting, this report assumed two Model AP-4 units by Pall Corporation, skid mounted and ready for installation. These packaged units would be furnished with all accessories required for membrane cleaning.

*Filtrate Break Tank and Intermediate Transfer Pumps* – A 15 minute retention time steel tank and two horizontal split case intermediate pumps are proposed to collect and pump the MF/UF filtrate through the next unit process – the water polishing GAC filters.

*GAC Filters* – Two packaged GAC filters are proposed to provide for additional removal of TOC from the MF/UF filter water. The assumed GAC filters are prefabricated packaged units ready for installation similar to Carbon Corporation Model 8, capable of treating flow rates of up to 350 gpm.

*CCT and Product Water Pumps* – A steel CCT is assumed to be constructed to provide for product water disinfection. The assumed CCT is sized for 45 minute contact time and it would also function as a wet well for the pump station. Two (one duty and one stand by) horizontal split case centrifugal pumps each with a pumping capacity of 307 gpm are proposed to pump the product water from the new WTP to a new water storage reservoir that would be located in Cambria next to the proposed Cambria Pump Station.

*Treatment Plant Site* – The location of the proposed WTP is just northwest of the existing Cayucos WTP and in a narrow piece of land between PCH and Cabrillo Street, and would occupy an approximate area of 1.25 acres. All process units would be located in a common building with GAC vessels and the product water pump station installed outdoors.

*Access* – Treatment plant access would be from Cabrillo Street, at US-1. There would be new on-site parking provided for the operators. The plant would be manned during normal working hours and as needed to operate the plant and perform maintenance and repairs.

*Security* – An eight (8) ft. tall chain-link security fence would be provided at the treatment plant and well sites to protect the facilities. The treatment plant processes would be housed inside a building for added security.

*Buildings* – Almost all of the facilities can be installed within an engineered prefabricated metal building, reducing noise and visual impacts. The building would be 60 ft. wide, 120 ft. long and 30 ft. tall. The building can be designed and landscaped to blend with the nearby community and provide security for facilities.

*Utilities* – Potable water, sanitary and solid waste services would be required. Adequate new power grid would need to be available for plant operation including pumping equipment.

*Waste Stream System* – The new WTP plant waste stream would be generated by MF/UF and GAC backwashing. It is assumed that the used filter back wash water would be collected and treated by inclined plate settler to separate solids from water. The settled water could be reused by recycling at head of the WTP and solids disposed in two drying lagoons.

*Other Miscellaneous Wastes* - Include neutralized clean-in-place solutions, instrumentation analyzer flows, rainwater collected in containment areas, domestic sewer flows from on-site rest room facilities, and other typical treatment waste flows. These flows should be discharged to an on-site septic tank, or the existing Cayucos wastewater system.

#### *Product Water Transmission and Connection to Cambria Distribution System*

The potable product water from the proposed WTP would be transported during the dry season to Cambria via the same pipeline used to deliver the source water during the wet season. This pipeline would be connected to the existing potable water distribution system in Cambria through the new product water storage reservoir. The new product water reservoir is sized for 12 hour storage and has storage capacity of 266,000 gallons. For cost estimating purposes, it was assumed that the product water reservoir would be a lined steel tank.

#### 3.2.7.5 Permitting Requirements

Implementation of this alternative would require obtaining permits from multiple permitting institutions, including but not limited to:

- **DWR** - to address additional water volume that would be stored in the Whale Rock Reservoir.
- **RWQCB** - to address additional pumping requirements from the Santa Rosa Creek and San Simeon Creek basins during winter wet season.
- **CDPH** - to address source and product water quality requirements and to approve the proposed water treatment process.
- **US Fish and Wildlife Service and California Department of Fish and Game Permits** - Drawing additional water from the Santa Rosa Creek and San Simeon Creek basins may have an impact to the natural and aquatic habitat within the stream corridor. Permits may need to be obtained from these two agencies.
- **CCC** – Since a number of the project proposed facilities in Cambria are within the coastal zone, Coastal Commission permitting would be required for consistency with costal development plan.

- **State Park** – none at this time.
- **Caltrans** – Construction activities along PCH are regulated by Caltrans. Since the proposed pipeline for water transmission between Cambria and the Whale Rock Reservoir would be built within the Caltrans ROW, a Caltrans permit application must be submitted.
- **Building Permits** - Grading and building permits may be required for the WTP, Cambria Pump Station and water storage reservoir.

In addition to the extensive permitting, implementation of this alternative would require extensive negotiations with the City and County of SLO regarding the use of their existing facilities within the Cayucos community as well as the Whale Rock Reservoir. These discussions may also extend to other member agencies of the Whale Rock Commission.

### 3.2.7.6 System Construction Requirements

#### *Construction Staging and Traffic Control*

It is anticipated that detailed traffic control plans need to be developed and extensive traffic control measures implemented along PCH during conveyance pipeline construction activities. Possible traffic control measures may include, but not be limited to, construction signs and signals, striping, flagging, detouring, key railing, flagman and others.

Construction staging for the WTP construction equipment and material would be accommodated in the empty lot between PCH and Cabrillo Street just north of 13th Street in Cayucos. It is estimated that a space size of up to 1.25 acres would be necessary. Construction staging for Cambria Pump Station and product water storage reservoir would be provided in an up to 1.5 acre open site just south east of the proposed site for the project facilities. Finally, construction staging for pipeline construction would be along PCH and within Caltrans ROW.

#### *Permanent Access*

Access to the water conveyance pipeline would be off of the PCH and within Caltrans ROW. Access to the WTP would be from PCH and local Cayucos 13th Street and Cabrillo Street. The plant would be manned during normal working hours and as needed to operate the plant and perform maintenance and repairs. Permanent access to the Cambria Pump Station and water storage reservoir would be from PCH and local Cambria Green Street. There would be up to three on-site parking lots at the WTP and Cambria Pump Station to provide for car parking of the WTP operators and visitors.

#### *Construction Access*

Construction access would be similar to the permanent access. Access to the WTP and pump station sites would be required for grading equipment, water trucks, cranes, equipment transportation trucks, laborers, forklifts and other construction equipment. Adequate temporary on-site parking during construction would be provided within the identified construction staging areas.

#### *Special Material and Equipment*

For the WTP, MF/UF equipment is proprietary and would need to be pre-selected or pre-purchased. Other equipment is readily available and would be part of the general contractor's scope of supply.

*Special Materials* - With exception of MF/UF proprietary equipment that needs to be pre-selected or pre-purchased, other system facility equipment is readily available and would be part of the general contractor's scope of supply. However, operation of the WTP would require transport and handling of chemicals at the plant site, including sodium hypochlorite, ferric chloride, sodium hydroxide, sulfuric acid and proprietary membrane cleaning solutions.

*Construction Equipment* - Construction equipment for WTP, Cambria Pump Station and water storage reservoir would consist of standard commercial construction equipment, including earth moving equipment, scrapers, graders, dozers, back hoes, vibrating compactors, loaders, cranes, forklifts, utility trucks, concrete trucks, and trailer mounted generators.

Pipeline construction would require standard pipeline construction equipment, including backhoes, vibrating compactors, loaders, cranes, utility trucks, and trailer mounted generators.

### *Buildings*

WTP and Cambria Pump Station would be constructed within a building to reduce noise and visual impacts. Buildings would be pre-fabricated metal buildings designed and landscaped to blend with the nearby community and provide security for facilities.

### *Operation*

The treatment plant and pump station would be designed for unmanned operation, However, minimal staffing is assumed for regular working hours from 8:00 am to 5:00 pm.

### *Construction Duration*

The proposed pipelines, pump station, storage reservoir and WTP can be bid and constructed as a single project or separate projects due to the differences in the types of contractors required and spread of geographical locations of the project facilities. For a project of this size and complexity, approximately 18 to 24 month construction period is required. Anticipated prolonged construction time (24 months) is required for construction of 16.5-mile long pipelines along PCH. Daily hours for construction activities would be limited by Caltrans, and the County and City of SLO construction permits. However, it is expected that construction hours would be between 7:00 am and 3:00 pm during five week days.

### 3.2.7.7 Engineering Cost Estimates

Planning level engineering cost estimate including capital and operating costs were prepared and are summarized as follows. Detailed cost estimating backup information is provided in Appendix A.

### *Construction Cost*

Summary of the estimate of probable construction cost is shown in Table 3.2.7-8. Construction Contingency of 30 percent has been provided. An allowance of 25 percent of the construction cost is added for surveying, geotechnical investigation, engineering design, construction management, permitting and legal fees, and CCSD administrative and staff expenses.



**Table 3.2.7-8 Conceptual Estimate of Probable Construction Cost**

Facility	Total
<b>Construction Cost without Lake Nacimiento</b>	
Cambria Pump Station	\$1,760,000
Whale Rock-Cambria water conveyance pipeline	\$13,068,000
Pipeline connection to Whale Rock Reservoir	\$495,000
Surface water treatment plant at Whale Rock Reservoir	\$1,768,000
Product water transfer pump station at Whale Rock WTP	\$480,000
Product water storage reservoir (in Cambria)	\$1,395,000
Subtotal	\$18,966,000
Contingency (30%)	\$5,690,000
<b>Total Construction Cost</b>	<b>\$24,656,000</b>
Project implementation cost (25%)	\$6,164,000
<b>Total Capital Cost</b>	<b>\$30,820,000</b>

*O&M Cost*

The conceptual O&M cost for the Whale Rock Reservoir alternative concept is shown in Table 3.2.7-9.

**Table 3.2.7-9 Annual O&M Costs**

O&M Costing Item	\$/Y (based on 6 Mo Operation)
Labor	\$75,000
Power	\$54,800
Chemicals	\$32,800
Consumables	\$46,000
Total O&M Cost	\$208,650
Contingency (15%)	\$31,300
<b>Total Annual O&amp;M Costs</b>	<b>\$239,950</b>

*Life Cycle Cost Analysis*

Life cycle costs for the Whale Rock Reservoir alternative concept are shown in Table 3.2.7-10. The cost analysis uses a cost of money of 3.5 percent for a period of 25 years.

**Table 3.2.7-10 Life Cycle Costs**

Criteria	Value
Project Design Life, years	25
Interest Rate	3.5%
Project Implementation Cost	\$30,820,000
Annual O&M Cost	\$239,950
Equivalent Uniform Annual cost (EUAC)	\$2,109,900
Present Worth Life Cycle Cost	\$52,748,000
Future Cost of the Project	\$82,180,000
Cost of Water, \$/AF	8,440

### 3.2.7.8 Summary of Benefits and Issues

#### *Benefits*

Major benefits brought by the Whale Rock Reservoir Alternative are as follows:

- Relatively low construction cost,
- High reliability of water sources,
- High quality of water,
- Use of proven technology and easy construction, and
- Straight forward regulatory permitting process.

#### *Issues*

Potential issues facing the Whale Rock Reservoir include:

- Complicated negotiation with Caltrans to obtain approval to build 16.5 mile conveyance pipeline along the PCH,
- Potentially complex negotiation with City and County of SLO for use of existing facilities, including the Whale Rock Reservoir, and
- The ten (10) inch diameter pipe size required by short wet season pumping duration would result in a low return flow velocity and longer travel time when water is pumped back to Cambria during the summer dry season. This could lead to the need for additional disinfection and related needs to address water quality concerns.

## 3.2.8 Alternative Concept 8 San Simeon CSD Recycled Water

### 3.2.8.1 Alternative Description

The San Simeon CSD Recycle Water concept is based on assumption that raw wastewater from the San Simeon community would be diverted to CCSD's Cambria WWTP for treatment and reuse as a tertiary effluent to offset potable water demand. Raw wastewater from the San Simeon WWTP would be diverted through a new wastewater pipeline to the existing Cambria WWTP owned and operated by CCSD. The diverted wastewater would be treated using primary, secondary, and tertiary processes to produce a Title 22 quality tertiary effluent that would be used as nonpotable recycled water in the Cambria community. The project would be able to operate year round, depending on the needs for recycled water.

This concept includes the following major components:

- Modifications to the San Simeon WWTP to add a new equalization basin and raw wastewater pumps/lift station,
- Wastewater forcemain from the San Simeon to the existing Cambria WWTP,
- Upgrades to the existing Cambria WWTP to include modifications and upsizing of the existing facilities, and construction of new tertiary treatment, disinfection and recycled water pumping facilities, and
- Recycled water reservoir and distribution pipelines in the Cambria community area.

See Figure 3.2.8-1 for the overall San Simeon CSD Recycled Water system layout. The new equalization basin and wastewater pump station would be located at the existing San Simeon WWTP. The new wastewater force main would be constructed along PCH in the Caltrans ROW. The existing Cambria WWTP headworks, primary, and secondary would be upgraded for additional flows, and a new tertiary treatment facilities would be added to produce California Title 22 tertiary effluent for nonpotable reuse. Potential users for the recycled water would be those previously identified by the CCSD's 2003 recycled water distribution system master plan.

Disinfection of the tertiary effluent would also be required using chlorination, or alternatively, UV light. The recycled water would have a chlorine residual between 2-4 mg/L. After disinfection, a new reclaimed water pump station would pump the recycled water for use by the Cambria community.

Conveyance lines and non-potable water services would be constructed in the Cambria area to distribute the reclaimed water. It is important to note that the reclaimed water can be used only for businesses and irrigation of public land such as parks, cemeteries, school yards, highway slopes and other public areas. Reclaimed water is not allowed for residential landscape irrigation.



### 3.2.8.2 Flows and Water Mass Balance

The design criteria for the major water supply concept facilities, including wastewater lift station, equalization basin, pipelines, treatment plant and product water conveyance and distribution, as well as descriptions of the system components, is provided in the subsequent sections.



San Simeon CSD  
Wastewater Conveyance Pipeline  
+/- 4.17 miles

**Legend**

-  San Simeon CSD Wastewater Conveyance Pipeline
-  San Simeon CSD Wastewater Pump Station
-  CCSD's WWTP



0 1,500 3,000  
  
 Feet  
 1 inch = 3,000 feet

**Cambria Water Supply  
 Technical Memorandum**

**Figure 3.2.8-1**  
 Water Supply Concept 8  
 San Simeon CSD Recycled Water Overall System Layout



### *Source Water*

Two sources of water supply, including wastewater from Cambria and San Simeon communities are assumed from this alternative.

### *Wastewater Flow from San Simeon Community*

The first source water for the San Simeon CSD Recycle Water concept would be raw wastewater diverted from the San Simeon community to CCSD that is currently treated at the San Simeon CSD's WWTP. The San Simeon WWTP has a design capacity for ultimate built out conditions of 200,000 gpd, with current average flows of about 60,000 gpd during the winter and 90,000 gpd during the summer tourist season. The plant produces a secondary effluent that is currently discharged to the ocean via an ocean outfall.

Newly constructed tertiary filters have a capacity to produce 25,000 gpd of Title 22 reclaimed water for irrigation in the San Simeon community area. Therefore, it is estimated that for the built out conditions, approximately 175,000 gpd, or 98.5 AF over period of six dry season months, of wastewater would be available for diversion to CCSD for treatment at their WWTP. San Simeon CSD indicated that they may increase the capacity of their new tertiary filtration for an additional 25,000 gpd, which would reduce the maximum potential daily source water for Cambria down to 150,000 gpd, or 84.5 AF over a period of six dry season months. Under current flow conditions, the flow available for transfer to the Cambria WWTP would be 65,000 gpd, or 36.6 AF over six months.

### *Water Flow from Cambria WWTP*

Because the maximum amount of raw wastewater that can be diverted from the existing San Simeon CSD WWTP and conveyed to CCSD would never be more than 150,000 - 175,000 gpd (84.5 – 98.5 AF per six months), this concept by itself cannot meet the required 442,000 gpd (250 AF) of the product water. To meet the targeted product water flow of 442,000 gpd (250 AF over six months), another 247,000 gpd -272,000 gpd of the recycled water would need to be produced from secondary effluent generated out of wastewater collected from Cambria's wastewater collection system.

With this assumption, out of the 600,000 gpd – 700,000 gpd of currently generated secondary effluent (1,000,000 gpd at ultimate built out conditions) at the Cambria WWTP, 326,000 gpd to 453,000 gpd, and 728,000 gpd at built out conditions, would continue to be discharged to the existing secondary effluent percolation ponds in the San Simeon Creek basin area, while the remaining flow would be treated to tertiary effluent quality and delivered to meet the reclaimed water demands in the Cambria area.

The existing Cambria WWTP consists of preliminary treatment, primary clarifiers, and activated sludge processes with nitrification and de-nitrification. The existing WWTP would need to be upgraded to treat the new flows from San Simeon and accommodate new tertiary filtration facilities. The plant's secondary effluent is currently pumped to the existing percolation ponds adjacent to San Simeon Creek through a 12-inch diameter pipeline constructed in 1996.

Once the secondary facilities are upgraded and new tertiary facilities constructed at the Cambria WWTP, the tertiary effluent product water from WWTP would be pumped into a reclaimed water distribution system that would be constructed in Cambria to convey the reclaimed water to nonpotable water users.

### Spent Backwash Water Flow

The tertiary treatment facilities would generate a waste stream out of the spent filter backwash water at flow rates between five to seven percent of the filter capacity. The spent backwash water would be returned back to the plant's headworks for retreatment and recycling, effectively eliminating almost all treatment losses and resulting in close to 100 percent recovery.

### 3.2.8.3 Water Quality

Wastewater quality for the San Simeon WWTP would not be significantly different from the water quality currently treated at the Cambria WWTPs. The product water quality would have to meet all water quality standards of the California Title 22 regulations for nonpotable use.

### Source Water

The source water for the San Simeon CSD Recycle Water concept is wastewater treated at the San Simeon WWTP. The San Simeon WWTP service area includes private residences, motels, restaurants, and other tourist facilities. Since Cambria has similar demographics and zoning, the wastewater quality of the San Simeon WWTP influent is assumed to be similar to that of the current Cambria WWTP influent. Assumed data for the source water quality are summarized in Table 3.2.8-1.

**Table 3.2.8-1 Assumed Source Water Quality**

Description	Units	Source Water Quality Average (range)
TSS	mg/L	280 (110-230)
BOD	mg/L	280 (110-230)
TDS	mg/L	850 (300-500)
pH	pH Unit	8 (7.0-8.5)
Temperature	Degree C	16 (14-20)

### Product Water

The preliminary product water quality goals are summarized in Table 3.2.8-2.

**Table 3.2.8-2 Product Water Quality Goals**

Description	Units	Proposed Goals	Regulatory Limit
TSS	mg/L	<15	20
BOD	mg/L	<15	20
TDS	mg/L	<350 <sup>1</sup>	500
pH	pH Unit	7.5 – 8.5	7 - 8.5

Notes:

<sup>1</sup> These values are the recommended limits for water used to irrigate the majority of ornamental and garden plants in California.

### 3.2.8.4 Description of the System Facilities

The San Simeon CSD Recycled Water concept consists of four key new facilities, including an equalization basin and wastewater lift station at the San Simeon CSD WWTP; a forcemain from the San Simeon WWTP to the Cambria WWTP; upgrades of the existing primary and secondary facilities and construction new headworks and tertiary treatment facilities at the Cambria WWTP; and the Cambria reclaimed water distribution system. In the following section, design criteria and description for each facility are provided with more details.

### System Design Criteria

The design criteria for the key proposed facilities are provided in the following Table 3.2.8-3. Description of each of the system components is provided in the subsequent sections.

**Table 3.2.8-3 Design Criteria**

Facility	Units	Criteria
<b>Flow Equalization Basin</b>	<b>gallon</b>	<b>87,500</b>
<b>Lift station at San Simeon WWTP</b>		
WWTP capacity	gpd	200,000
Current influent flow rate	gpd	60,000-90,000
Tertiary treatment for San Simeon	gpd	25,000
Available for Transfer to CCSD	gpd	175,000
Available for Transfer to CCSD	gpm	122
Available for Transfer to CCSD per Year	AFY	98
Available for Transfer to CCSD - 6 Mo dry season	AF/6 Months	49
Lift station TDH	ft	218
Lift station pump capacity	gpm	243
Lift station horse power	HP	43
Number of pumps	#	2
<b>Wastewater Forcemain</b>		
Pipe capacity	gpm	243
Velocity	fps	2.7
Pipe diameter	inch	6
Pipe length	ft	21786
Pipe material		HDPE
<b>CCSD's WWTP Upgrades</b>		
Headworks upgrades	gpd	1,000,000
Primary upgrades	gpd	175,000
Secondary upgrades	gpd	175,000
Tertiary treatment	gpd	442,000
Disinfection	gpd	442,000
<b>Recycled Water Booster Pumps</b>		
Pump station capacity	gpd	442,000
Pump station capacity	gpm	307
Pump station TDH	ft	239
Pump station horse power	HP	60
Number of pumps	#	2
Pump drive	type	VFD
Pumps efficiency	%	75
<b>Tertiary effluent distribution pipeline</b>		
Pipeline capacity	gpm	307
Velocity	fps	7-Apr
Pipe diameter	inch	6
Pipe material	Type	PVC
Pipe length	ft	15840

### San Simeon CSD Wastewater Equalization Basin

The existing San Simeon WWTP tertiary filters would continue to operate at capacities of 25,000 to 50,000 gpd, while 150,000 to 175,000 gpd of the San Simeon community’s raw wastewater would be pumped to Cambria WWTP for treatment. It is assumed that the new wastewater pump station would operate 12 hours per day, which would require an 87,500 gallon wastewater equalization basin. The equalization basin would be constructed at the San Simeon WWTP and furnished with mixers and air blowers to prevent septic conditions in the equalized wastewater.

### San Simeon CSD Wastewater Pump Station

A new wastewater pump station at the San Simeon WWTP would pump raw wastewater to the Cambria WWTP for primary, secondary and tertiary treatment. The pump station would include a wet well connected to the proposed equalization basin, submersible pumps, piping and appurtenances such as isolation valves, check valves, air pressure and vacuum release valves, flow meter and others. The pump station would be designed to accept raw wastewater collected from the San Simeon community area. The capacity of the pumps would be as shown in the design criteria table.

### Wastewater Conveyance

The source water, in this case raw wastewater, would be conveyed through an approximately 22,000 ft. long 6 inch diameter pipeline that would be installed along PCH from the San Simeon WWTP to the Cambria WWTP.

### Wastewater Treatment

Treatment of the diverted wastewater from San Simeon WWTP would be performed at the Cambria WWTP with expanded and upgraded existing wastewater treatment facilities, and newly constructed headworks, tertiary filtration and disinfection. Wastewater treatment would include preliminary treatment at the headworks, primary treatment, secondary treatment, and tertiary treatment and disinfection. Figure 3.2.8-2 presents a process schematic of the Cambria WWTP treatment processes, including the tertiary treatment processes to produce the water for reuse. Existing facility upgrades are colored blue (primary clarifier, aeration basins, secondary clarifier) while new construction is colored grey (headworks, tertiary filters, chlorine contact basin).

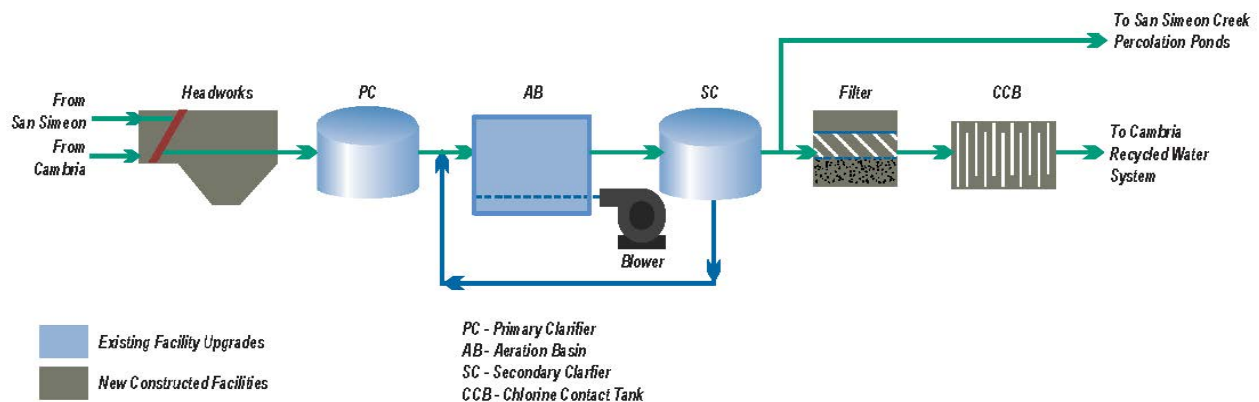

Figure 3.2.8-2 CCSD WWTP Process Schematic



The current headworks of the Cambria WWTP consist of fine screens and grit chamber. The existing headwork facilities are undersized and in need for a complete reconstruction. Therefore, it is assumed that a new headworks facility would be constructed at a capacity large enough to receive the influent from both the Cambria and San Simeon communities. Construction costs for this facility are prorated proportional to the influent flow rates.

It is assumed that additional capacity to accommodate the added flows from the San Simeon and the Cambria WWTPs would be acquired by upgrading and improving performance of the existing primary clarifier and activated sludge facilities without expanding their physical footprints.

Based on an initial survey of the facility sizes, hydraulic loadings of these facilities with an influent flow increase of up to 165,000 gpd would still stay below acceptable criteria for municipal wastewaters. The proposed new headworks would be more efficient and would reduce solids loading at primary clarifiers and activated sludge facilities. Similarly, upgrades of the existing activated sludge system with more efficient aeration systems would provide the required oxidation of the wastewater from the increased influent flow rates.

The new facilities required for this water supply concept include tertiary filters; water disinfection and recycled water pump station. The California Department of Public Health approved pre-engineered filters, such as DynaSand or FuzzyFilters, are assumed for this application. Together with tertiary filters, the chlorine disinfection system with CCT'S would be constructed within available space at the existing Cambria WWTP. As an alternative, an UF membrane system and a UV light system for disinfection could be implanted instead because it has a smaller foot print requirement, and might have less of an impact on the Cambria WWTP site.

The new Cambria WWTP upgrades would be sized for a product water capacity of 307 gpm (442,000 gpd) and would be able to operate all year round, though the demands would be seasonal. Therefore, while there may be a strong demand for the reclaimed water during the dry summer months, during the wet winter season, the tertiary facilities might be shut down or partially shut down due to lack of demand.

#### *Waste Stream System*

There are two waste streams from the Cambria WWTP expansion, including an additional solids waste stream and the tertiary filter backwash water. The wastewater solids would be treated in the same manner as the existing Cambria WWTP. The tertiary filter spent backwash water would be returned to the plant's headworks for retreatment and recycling.

#### *CCSD Recycled Water Distribution System*

The product water from the tertiary treatment would be pumped into a new Cambria recycled water distribution system after disinfection at the Cambria WWTP. The system would consist of a pumping station, a storage reservoir to equalize daily flows at the WWTP, and recycled water conveyance pipelines and distribution network in the Cambria community area.

#### 3.2.8.5 Permitting Requirements

Implementation of this alternative would require obtaining permits from multiple permitting institutions including but not limited to:

- **Coastal Commission** - permitting would be required for consistency with coastal development plan since the entire project is within the Coastal Zone boundary.

- **RWQCB** - would issue a permit for the expanded CCSD WWTP and reclaimed water system. An Engineering Report would be required.
- **CDPH** - would be required to address source water control and product water quality requirements and approve the proposed water treatment processes.
- **Building Permits** – grading and building permits may be required for the CCSD WWTP.
- **Caltrans** - a permit to construct the pipeline in the PCH ROW would be required.

#### 3.2.8.6 System Construction Requirements

The San Simeon raw wastewater lift station and equalization basin would be constructed at the existing treatment WWTP site. The conveyance pipeline would be constructed along the PCH in the Caltrans ROW, which would require traffic control on the highway. The CCSD wastewater facilities would be constructed within the boundaries of the existing Cambria WWTP. The recycled water distribution system would be constructed in existing streets throughout the Cambria community area.

##### *Staging Location and Area*

All staging areas of the proposed facilities would be within the San Simeon WWTP yard or on the CCSD owned land next to the Cambria WWTP. The staging locations for equipment, materials, and construction worker parking would be on flat areas around the treatment plant process building, including future parking, landscaped and open areas.

##### *Construction Accessibility*

Construction access for the San Simeon and Cambria WWTP facilities would be from the existing streets and access roads. Access to the proposed construction areas would be required for grading equipment, water trucks, cranes, equipment transportation trucks, and construction laborers. Adequate on-site parking during construction would be provided.

Construction access for the pipeline would be from PCH. Traffic control would be required.

##### *Special Material and Equipment Requirements*

For the treatment plant, equipment is readily available and would be part of the general contractor's scope of supply. Operation of the Cambria WWTP would require transport and handling of chemicals at the plant site including sulfuric acid, ferric chloride and sodium hypo-chloride. If membranes are used for tertiary filtration, additional chemicals would include sodium hypochlorite, sodium hydroxide, and various cleaning solutions.

The treatment plant construction equipment would consist of standard commercial construction equipment, including earth moving equipment, scrapers, graders, dozers, back hoes, vibrating compactors, loaders, cranes, , forklifts, utility trucks, concrete trucks, and trailer mounted generators .

Pipeline construction equipment would consist of standard pipeline construction equipment, including backhoes, vibrating compactors, loaders, cranes, utility trucks, and trailer mounted generators.

##### *Construction Duration*

The proposed wastewater lift station, equalization basin, forcemain line, Cambria WWTP upgrades and reclaimed water system would be constructed in 14 to 18 months, assuming a typical five day per

week schedule. Daily hours for construction activities would be limited by the County of SLO construction permits. However, it is expected to be between 7:00 am and 4:00 pm. Construction of multiple project facilities can be ongoing at the same time.

### 3.2.8.7 Engineering Cost Estimates

Planning level engineering cost estimates (including capital and operating costs) were prepared for the construction and O&M as summarized below. Detailed cost estimating backup information is provided in Appendix A.

#### *Construction Cost*

A summary of the estimate of probable construction costs is shown in Table 3.2.8-4. A construction contingency of 30 percent has been provided. An allowance of 25 percent of the construction cost is added for surveying, geotechnical investigation, engineering design, construction management, permitting and legal fees, and other CCSD administrative and staff expenses.

**Table 3.2.8-4 Conceptual Estimate of Probable Construction Costs**

Facility	Total
San Simeon WWTP Pump Station and Equalization Basin	\$519,000
Force main	\$1,961,000
Cambria WWTP Upgrades	\$7,942,000
Cambria Recycled Water Distribution System	\$2,377,000
Subtotal	\$12,799,000
Contingency (30%)	\$3,840,000
<b>Total Construction Cost</b>	<b>\$16,639,000</b>
Project Implementation Cost (25%)	\$4,160,000
<b>Total Capital Cost</b>	<b>\$20,798,000</b>

#### *O&M Cost*

The conceptual O&M costs for the San Simeon CSD recycled water alternative is shown in Table 3.2.8-5 based on 442,000 gpd and 183 day operation.

**Table 3.2.8-5 Annual O&M Costs**

Facility	Total
Labor	\$37,500
Power	\$91,400
Chemicals	\$16,100
Consumables	\$20,200
<b>Total O&amp;M Cost</b>	<b>\$165,200</b>
Contingency (15%)	\$24,800
<b>Total Annual O&amp;M Cost</b>	<b>\$190,000</b>

#### *Life Cycle Cost Analysis*

The analysis of life cycle costs for the San Simeon CSD recycled water alternative is shown in Table 3.2.8-6. The Cost Analysis uses a cost of money of 3.5 percent for a period of 25 years.

**Table 3.2.8-6 Life Cycle Costs**

Facility	Total
Project Design Life, Year	25
Interest Rate	3.5%
Project Implementation Cost	\$20,798,000
Annual O&M Cost	\$190,000
EUAC	\$1,452,000
Present Worth Life Cycle Cost	\$36,298,000
Future Cost of the Project	\$56,552,000
Cost of water, \$/AF	5,808

### 3.2.8.8 Summary of Benefits and Issues

#### *Benefits*

The benefits with implementing this alternative are provided as follows:

- Use of proven technology,
- Off-sets potable water demands, and
- Skilled CCSD staff for O&M of wastewater facilities, no learning curve.

#### *Issues*

The major potential issues facing this alternative include the following:

- San Simeon wastewater diversion alone would not provide desired amount of water that would offset the increased water demand for Cambria community during six months dry weather season,
- Limitation to use nonpotable recycled water only for businesses and irrigation of public areas may not generate enough demand for recycled water to offset the increased water demand of the Cambria community during six months dry weather conditions,
- Construction of recycled water distribution pipeline along Cambria streets and roads, and
- Permitting pipeline along PCH in Caltrans ROW.

# Section 4

## Evaluation of Tier II Alternative Concepts

### 4.1 Evaluation Process

Evaluation of Tier II Alternative Concepts required an objective, transparent and defensible process. Based on proven decision science methodology, an evaluation technique called MAR was selected and used to compare and rank alternatives. MAR uses a criteria, metrics, and weights in order to calculate a normalized decision score for each alternative for the purposes of making objective comparisons and relative ranking. Figure 4.1.1-1 illustrates the evaluation process, using the data and engineering results that were described in Section 3 for the Tier II Water Supply Concepts.

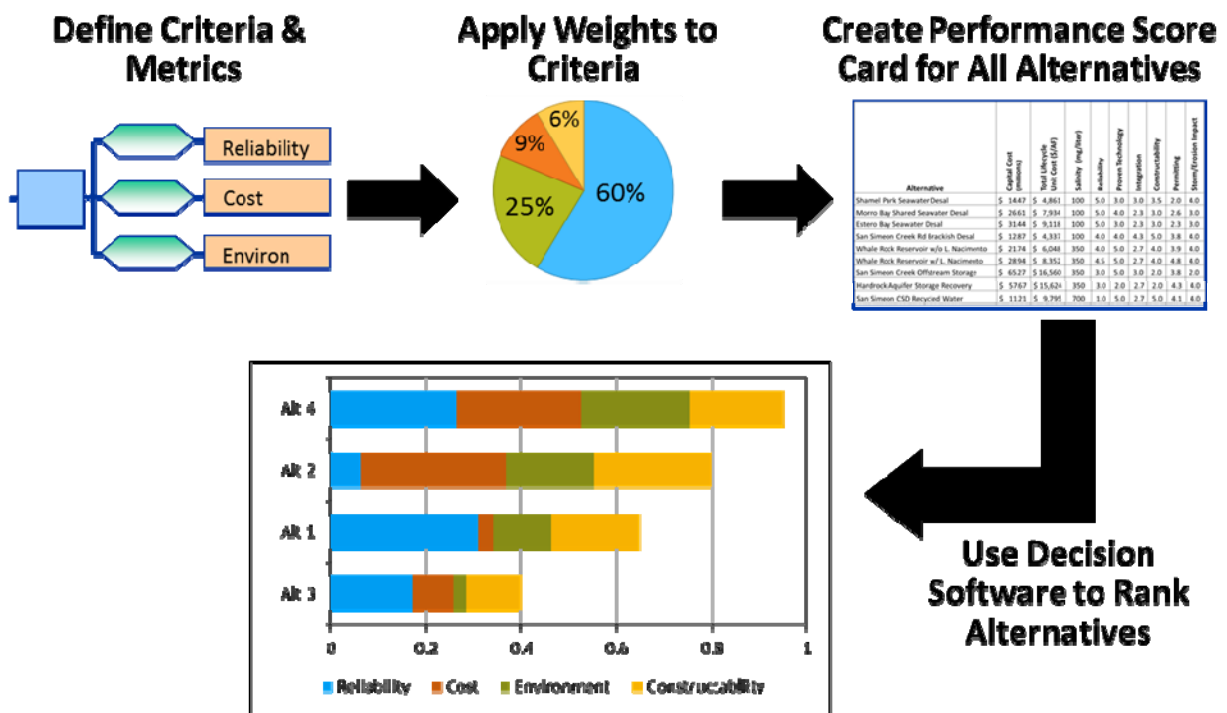

Figure 4.1.1-1 Tier II Alternative Concept Evaluation Process

### 4.2 Stakeholder Process

A stakeholder process was used to: (1) obtain input on the water supply concepts; (2) help define the criteria and assign criteria weights; and (3) review the evaluation and ranking of alternatives. Stakeholders, who represented different perspectives of the Cambria public and who had an interest in this study, participated in four workshops. It should be noted, however, that the stakeholders involved in these workshops were self-selecting and did not necessarily reflect all perspectives of the general Cambria public. Nonetheless, these stakeholders provided crucial input to the deliberations of the CCSD Board. Table 4.2.1-1 lists the workshops and major topics discussed.

**Table 4.2.1-1 Stakeholder Workshops for Water Supply Concept Alternatives Evaluation**

Workshop	Topics Discussed
Workshop 1 – June 14, 2012	<ul style="list-style-type: none"> <li>▪ Initial water supply concepts</li> <li>▪ Preliminary screening of water supply concepts</li> <li>▪ Overview of evaluation methodology</li> <li>▪ Draft evaluation criteria</li> </ul>
Workshop 2 – July 19, 2012	<ul style="list-style-type: none"> <li>▪ Revised evaluation criteria</li> <li>▪ Criteria weighting exercise</li> </ul>
Workshop 3 – August 9, 2012	<ul style="list-style-type: none"> <li>▪ Final review of Tier II water supply concepts</li> <li>▪ Initial ranking of Tier II water supply concepts</li> <li>▪ Sensitivity analysis of ranking</li> </ul>
Workshop 4 – September 19, 2012	<ul style="list-style-type: none"> <li>▪ Revised concept ranking with smaller project size (250 AF)</li> <li>▪ Public comments</li> <li>▪ Decision on which concept alternatives would be in EIR/EIS</li> </ul>

Each of the stakeholder workshops was facilitated to ensure that the views of participants were adequately expressed, that participants were respectful towards each other and the technical team, and that the process continued to advance. The last point was very important because of the federal schedule to produce the EIR/EIS.

## 4.3 Decision Software and Data Inputs

### 4.3.1 Decision Software

There are several software packages that are commonly used to implement a MAR evaluation process. For this study, CDP, by InfoHarvest (<http://infoharvest.com/ihroot/index.asp>), was used. CDP is able to incorporate both quantitative metrics (measured on a continuous scale) and qualitative metrics (measured on discrete or ordinal scales) in order to develop a normalized, standard decision score for any alternative for comparison and ranking. CDP clearly illustrates the trade-offs between the criteria and can conduct sensitivity analyses quickly. Figure 4.3.1-1 summarizes the mathematics behind CDP's ranking.

In **Step 1** of the CDP process, a raw performance measure (or metric) is compared for all alternatives—in this case, cost. **Step 2** of the process creates a standardized score from the raw performance measures using a “satisfaction level” or sometimes referred to as utility function—in this case, Alternative 6 has a cost of \$3 million which translates into a standardized score of 3.4 (out of a possible 10 score). **Step 3** of the process assigns weights to the objective or criteria—in this case, the cost criteria is given a weight of 9 percent out of a possible 100 percent total. **Step 4** calculates a partial score for the alternative and criteria in question, which equals the standardized score multiplied by the criteria weight—in this case, the partial score for cost for Alternative 6 is 0.31. **Step 5** plots the partial score for the alternative and criteria in question. **Step 6** repeats Steps 1-5 for all other criteria for the alternative in question. **Step 7** repeats the entire process (Steps 1-6) for all alternatives to allow for comparison and relative ranking.

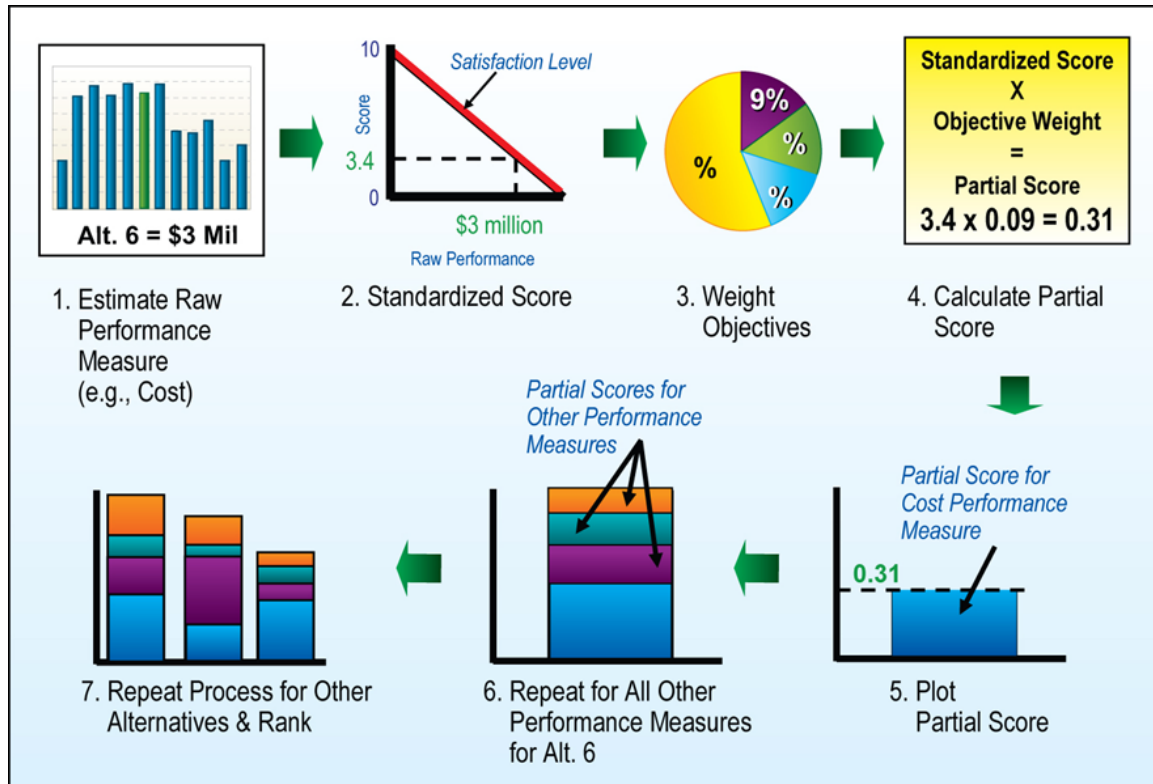

Figure 4.3.1-1 Ranking Methodology used by Criterium DecisionPlus Software

### 4.3.2 Data Inputs

The first input to the decision process is the definition of criteria. Criteria define the major goals or objectives that the water supply concept alternatives are trying to achieve. There are several important attributes that a good list of criteria should have, which are:

- Understandable – criteria should be understood by a broad range of people,
- Measurable – criteria need to be able to be measured, either quantitatively or qualitatively,
- Non-Redundant – criteria need to measure distinctly different things, with little overlap in goals, and
- Concise in Numbers – criteria should be kept to a relatively concise number, five to seven in order to make comparisons between alternatives meaningful.

Once the criteria are defined, performance metrics are established that would be used to indicate how well a water supply concept achieves the criteria. Any criterion may have one or more performance metrics. Table 4.3.2-1 presents the seven criteria and associated metrics that were finalized with input from the stakeholders.

**Table 4.3.2-1 Evaluation Criteria and Metrics**

Criteria	Description	Metric(s)
Reliability of Source Water	Evaluates the reliability of source waters to meet existing demands and approved service connections, under all hydrologic, seasonality and emergency conditions.	<ul style="list-style-type: none"> <li>A relative score from 1-5, where 5 = superior reliability and 1 = poor reliability</li> </ul>
Water Quality (Hardness/Salinity)	Reflects impacts of water hardness/salinity on pipes, water heaters, and irrigation.	<ul style="list-style-type: none"> <li>The estimate total dissolved solids of water produced in mg/liter</li> </ul>
Proven Technology & Integration	Considers the history and proven track record of the proposed technology, as well as integration into existing delivery system.	<ul style="list-style-type: none"> <li>A relative technology score from 1-5, where 5 = most proven and 1 = least proven</li> <li>A relative integration score from 1-5, where 5 = easiest integration and 1 = most difficult integration</li> </ul>
Cost-Effectiveness	Examines the capital cost, as well as total lifecycle cost (including annual operating costs.	<ul style="list-style-type: none"> <li>Total capital cost of concept in \$2012</li> <li>Total lifecycle cost (capital and O&amp;M) divided by total water yield, expressed as \$/AF</li> </ul>
Erosion/Storm Impacts	Considers the potential for exposure of the project facilities to erosion and storm event impacts such as seawater intake, concentrate return, reservoir sediment deposits and riverbed erosion.	<ul style="list-style-type: none"> <li>A relative score from 1-5, where 5 = little impact from erosion or storms and 1 = significant potential impact</li> </ul>
Constructability & Permitability	Examines the accessibility for construction as well as permitting requirements and potential challenges (e.g., permits for coastal, aquatic impacts, public health, etc).	<ul style="list-style-type: none"> <li>A relative constructability score from 1-5, where 5 = easiest to construct and 1 = hardest to construct</li> <li>A relative permitability score from 1-5, where 5 = easiest to permit and 1 = most difficult to permit</li> </ul>
Environmental/Green Approach	Reflects environmental considerations, such as energy use, brine, and impacts to ecosystems.	<ul style="list-style-type: none"> <li>A relative score from 1-5, where 5 = most green/environmentally friendly and 1 = least green/environmentally friendly</li> </ul>

Stakeholders were provided with a form to assign relative weights to each of the criteria, with the sum total equaling 100 percent. Figure 4.3.2-1 presents the results of this weighting. The blue bar indicates the full range of weights assigned by the stakeholders; with the lowest and highest ends of the bar indicating that at least one stakeholder indicated that was his/her minimum or maximum weights for that specific criterion. The average weight for all stakeholders is indicated by the red triangle. As indicated in the figure, the five most important criteria had average weights ranging from 13 to 31 percent. Two criteria had average weights that were lower than five percent.



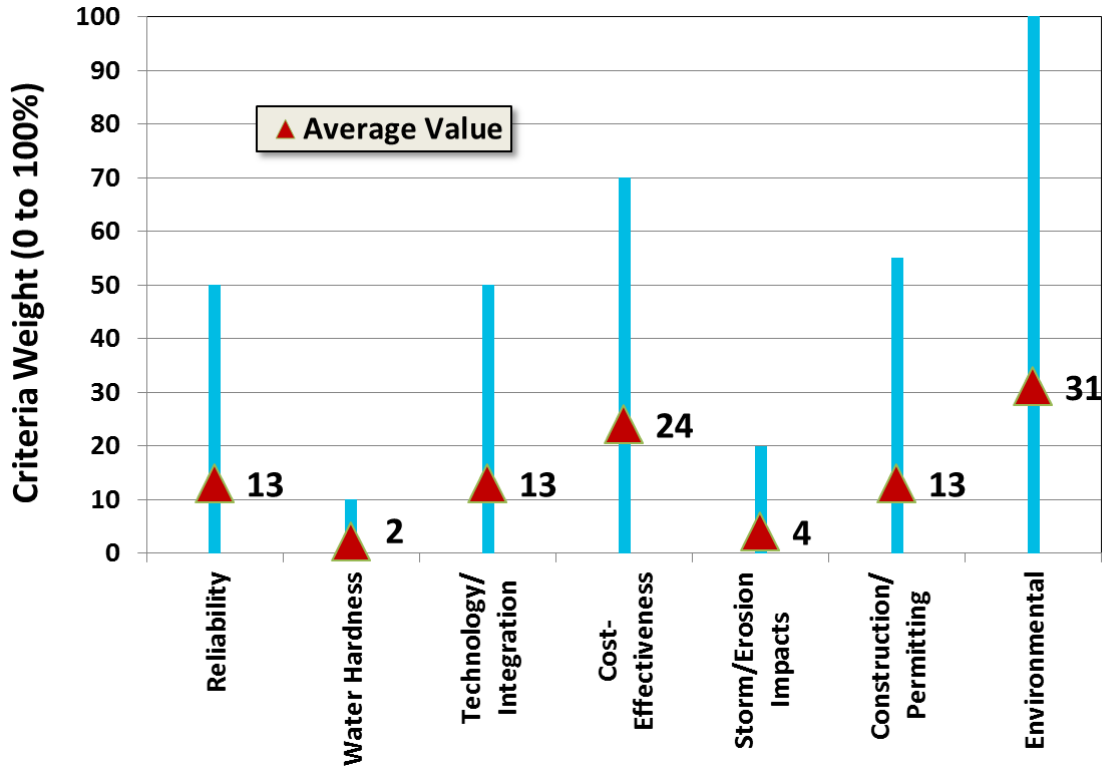

Figure 4.3.2-1 Stakeholder Assigned Weights for Evaluation Criteria

The Tier II water supply concepts were originally sized based on a need for 400 AF of dry year need. The evaluation method and software described earlier was used to evaluate these concepts at that project size. At the suggestion of the CCSD Board, the size of the concept projects was reduced to 250 AF. Table 4.3.2-2 presents the evaluation metrics for the 250 AF sized project concepts.

Table 4.3.2-2 Evaluation Metrics for Tier II Water Supply Concept Alternatives

Alternative	Capitol Cost (millions)	Total Lifecycle Unit Cost (\$/AF)	Salinity (mg/liter)	Reliability	Proven Technology	Integration	Constructability	Permitting	Storm/Erosion Impact
Shamel Park Seawater	\$17.94	\$5,730	100	5.0	3.0	3.0	3.5	2.0	4.0
Morro Bay Shared SWRO	\$28.13	\$8,340	100	5.0	4.0	2.3	3.0	2.6	3.0
Estro Bay Mineral Terminal	\$32.46	\$9,342	100	5.0	3.0	2.3	3.0	2.3	3.0
San Simeon Creek Road Brackish Water	\$15.92	\$5,047	100	4.0	4.0	4.3	5.0	3.8	4.0
Whale Rock Reservoir	\$26.89	\$7,357	350	4.0	5.0	2.7	4.0	3.9	4.0
San Simeon Creek Offstream Storage	\$68.71	\$17,955	350	3.0	5.0	3.0	2.0	3.8	2.0
Hardrock Aquifer Storage Recovery	\$15.20	\$20,422	350	3.0	2.0	2.7	2.0	4.3	4.0
San Simeon CSD Recycled Water	\$21.79	\$6,075	700	1.0	5.0	2.7	5.0	4.1	4.0

## 4.4 Evaluation Results and Concept Ranking

Water supply concept alternatives were ranked based criteria, criteria weights and metrics presented in Section 4.3. This ranking is based on a concept project size of 250 AF. Figure 4.4.1-1 presents the results of this ranking using all criteria. The longer the color segment bars, the better the alternative performs for that specific criterion.

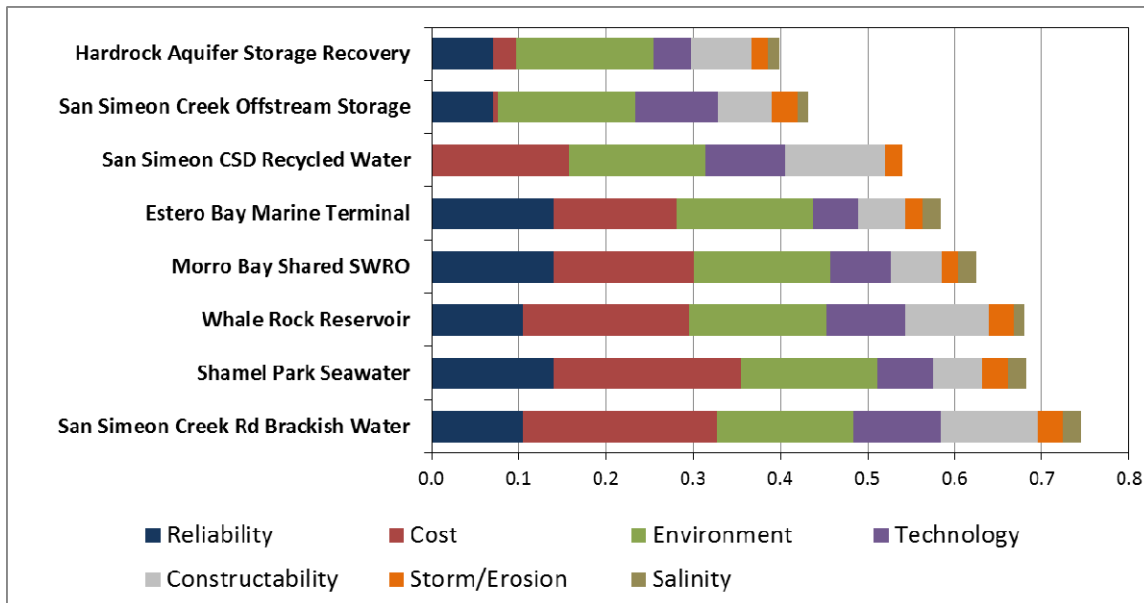

**Figure 4.4.1-1 Ranking of Alternatives Using All Criteria**

Some stakeholders suggested that the ranking of alternatives should only use the five most important criteria, but have all of those five criteria weighted equally. Figure 4.4.1-2 presents this ranking with the five most important criteria equally weighted.

Table 4.4.1-1 compares the two rankings. This comparison indicates that the San Simeon Creek Road Brackish Water project ranks first in both criteria weighting schemes. Shamel Park Seawater ranked second when all criteria are considered with stakeholder assigned weights, but drops to a ranking of third when only the five most important criteria are used and equally weighted. Whale Rock Reservoir ranks third when all criteria are used, but moves up to second when just the important criteria are used. All of the other project rankings stay the same regardless of the criteria weighting schemes. The Hardrock Aquifer Storage Recovery project always ranks last.

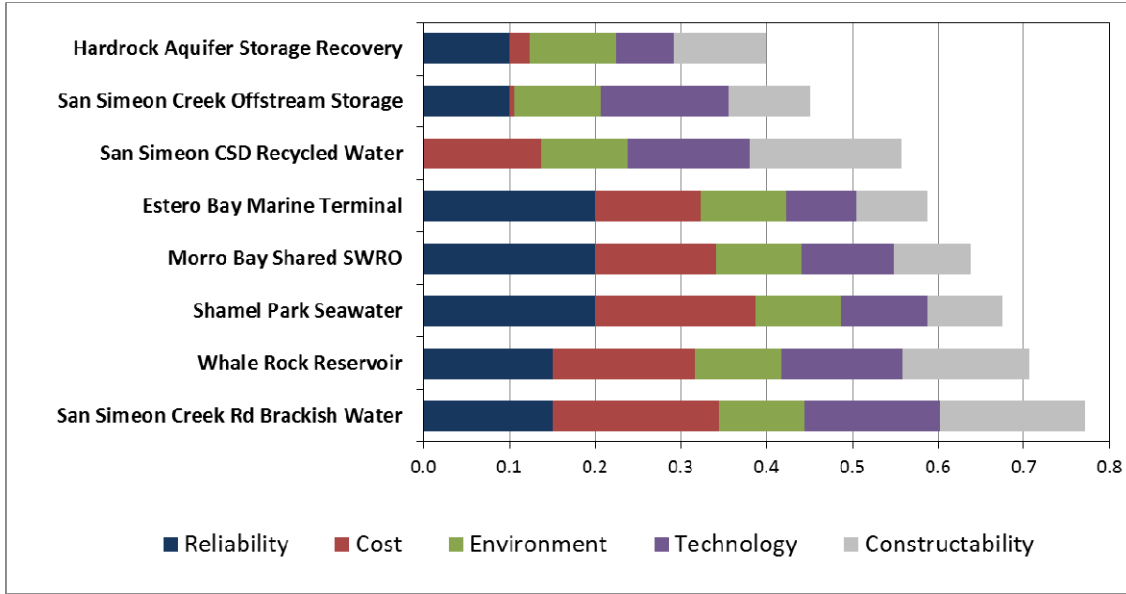

Figure 4.4.1-2 Ranking of Alternatives with Five Most Important Criteria Equally Weighted

Table 4.4.1-1 Comparison of Rankings

Criteria Weighting	San Simeon Creek Rd Brackish Water	Shamel Park Seawater	Whale Rock Reservoir	Morro Bay Shared SWRO	Estero Bay Marine Terminal	Simeon CSD Recycled Water	San Simeon Creek Offstream Storage	Hardrock Aquifer Storage Recovery
Workshop Weights	1	2	3	4	5	6	7	8
Most Important Weights	1	3	2	4	5	6	7	8

This page intentionally left blank.

## Section 5

# Summary of Study Results and Recommendations

Based on the evaluation criteria established by the project team and project stakeholders including CCSD, Cambria community residents and resource agencies, this TM ranked the Tier II Alternatives by applying MAR evaluation technic, and using the CDP software package.

Two rankings have been completed including one based on all seven evaluation criteria and their weights as established by the project team and all stakeholders during public workshops (“All Criteria” evaluation); and a second ranking based on only five most important and equally weighted criteria (“Most Important Criteria” evaluation). The results are highlighted as follows:

- The San Simeon Creek Road Brackish Water alternative ranked number one by both evaluations due to the low cost, proven technology and the easy constructability and permitability.
- The Whale Rock Reservoir alternative ranked number two by the “Most Important Criteria” evaluation due it’s proven technology and relatively easy permitability. The same alternative ranked a close third for the “All Criteria” evaluation - one rank lower, primarily due to this alternative having relatively less reliability than the Shamel Park Seawater alternative.
- The Shamel Park Seawater alternative ranked second by the “All Criteria” evaluation due to the project’s high reliability and relatively low construction cost. This alternative ranked third by the “Most Important Criteria” evaluation - one rank lower due to more complex permitability.
- The Morro Bay Shared SWRO alternative ranked fourth by both evaluations. It was rated as favorable due to its high reliability and relatively easy constructability and permitability. Also, the Morro Bay Shared SWRO alternative has the advantage of using the existing SWRO facility. The ranking was lowered because of long product water pipeline and uncertainty of concentrate disposal when the California state regulation to prohibit the single pass cooling systems at power plants becomes implemented.

The other four alternatives considered in the Tier II evaluation ranked lower due to various reasons, including high cost (San Simeon Creek Off-stream Storage alternative); low reliability (San Simeon CSD Recycled Water alternative); high cost and low reliability (Hard Rock Aquifer Storage and Recovery alternative); and high cost and low level of confidence in existence and capacity of the Toro Creek Paleochannel (Estero Bay Marine Terminal alternative).

Based on the evaluation rankings, it is recommended that the three highest ranked alternatives be carried over for further assessment by the EIS. These three alternatives are based on three different water sources including:

1. Ground water blend of percolated secondary effluent, basin fresh ground water and deep aquifer brackish water,( San Simeon Creek Road Brackish Water Alternative)
2. Seawater (Shamel Park Seawater Alternative), and
3. Surface water (Whale Rock Reservoir Alternative).

Due to convenience and low cost of the existing SWRO treatment plant upgrades, ease to expand seawater intake capacity by adding few more beach wells along Morro Bay, and established concentrate return practice via the existing Morro Bay Power Plant ocean outfall, it is also recommended that Morro Bay Shared SWRO alternative be included in the further EIS evaluation.

Engineering concepts of the highest rank San Simeon Creek Road Brackish Water alternative were developed based on the data and other information from the 1998 USGS report. In order to confirm basic concepts of this alternative and to provide credible EIS documents, a hydrogeological model of the basin that incorporates the existing and proposed new facility is recommended.

## Section 6

# References

- Cambria Community Services District, *2011 Consumer Confidence Report*, July 2012.
- Cambria Community Services District, *2010 Urban Water Management Plan, Final Report*, p. 5-7. February 23, 2012.
- Cambria Community Services District, *Ground Water Recharge Project, Final Environmental Impact Report*, December 1991.
- CDM Smith, *Draft TM Support for In-Stream Flow Study on San Simeon and Santa Rosa Creeks*, September 2012.
- CDM Smith and Geoscience, *TM 4.1.9A Concentrate Return Alternatives*, February 8, 2012.
- CDM Smith and Geoscience, *TM 4.1.1A Seawater Intake Alternatives*, February 3, 2012.
- CDM Smith, *TM 4.1.4A Seawater Treatment Plant Alternatives*, August 4, 2011.
- CDM Smith, *Support for In-Stream Flow Study on San Simeon and Santa Rosa Creeks*, September 11, 2012 (in appendix B).
- Data gathered CCSD's WWTP, Telephone conversation with Mike Finningan, June 27, 2012.
- Data for San Simeon WWTP, Collected in telephone conversation with Charlie Grace of San Simeon CSD on June 29, 2012.
- Diaz, Yourman Associates, *Geotechnical Study Report – Cambria Water Supply, SLO County, California*, July 27, 2012.
- Fryer, James, *A Review of Water Use and Water Management Alternatives in Cambria, California*, June 2012.
- Gresens, Bob, Meeting noted from meeting with Chevron on El Toro terminal, February 28, 2012.
- Information acquired from Tim Cleat, Telephone call and Tim's additional notes and comments on notes, June 27, 2012.
- John Carollo Engineers, *Concentrate Disposal Alternatives*, May 1992.
- John Carollo Engineers, *Hydrologic Evaluation of the Design and Impacts of Cambria Community, Services District's Proposed Groundwater Recharge Project*, November 25, 1991.
- Kennedy/Jenks Consultants, *Baseline Water Supply Analysis, Cambria Community Services District, , K/J 004621.00, Appendix D, p.2*, December 8, 2000.
- San Luis Obispo, City of, *Chapter 8 Water and Wastewater General Plan*, July 6, 2010.
- San Luis Obispo County Department of Public Works, *Cayucos Water Treatment Plant Capacity Study Feasibility*, November 2, 2010.

Settlement agreement between The Warren Trust and CCSD executed on November 6, 2006.

US Geological Survey, *Geological Map of the Cambria Region*, San Luis Obispo, California, Map MF-599, sheet 1 of 2.

Yates, Eugene B. and Kathryn M. Van Konyneburg, *Hydrology, Water Quality, Water Budgets, and Simulated Responses to Hydrologic Changes in Santa Rosa and San Simeon Creek Ground-Water Basins*, San Luis Obispo, California, US Geological Survey, 1998.



Appendix A  
Cost Estimating Spreadsheets

**This page was intentionally left blank for duplex printing.**

Cambria - Water Supply Alternative Concepts

1. Shamel Park Seawater

Construction cost for 250 AF six month water production system

Cost Item	Diameter (in) Capacity (gpm) Depth (ft) volume (yds)	Unit	Number	Cost/Unit	Total	Comments
<b>Seawater Intake</b>						
HDDW seawater intake well						
Well construction	12 inch/1350 ft	ea	1	2,577,696	2,577,696	Based on TM 4.1.1A, pg. 4-62, item 4.4.5.1
Well equipment		ea	1	374,410	374,410	Based on TM 4.1.1A, pg. 4-62, item 4.4.5.1
<b>Total beach wells</b>					<b>2,952,107</b>	
<b>Seawater Pipeline</b>	12 inch	ft	1,608	150	241,200	Assumed \$15/inch-ft
<b>Total seawater pipeline</b>					<b>241,200</b>	
<b>SWRO Treatment Plant</b>						
<i>Pretreatment - particulate removal</i>						
<i>Pretreatment - chemical pretreatment</i>						
<i>SWRO</i>						
<i>RO booster pumps</i>						
<i>Energy recovery</i>						
<i>Product water post treatment/stabilization</i>						
<i>Disinfection</i>						
<b>Total SWRO treatment plant</b>		<b>EA</b>	<b>1</b>	<b>4,707,594</b>	<b>4,707,594</b>	Based on TM 4.1.4, pg. 7-8, Table 7-7 w/o treated water and concentrate PSs
<b>Concentrate return</b>						
<i>Concentrate return pump station</i>	Two 30 hp pumps	ea	1	290,704	290,704	Assumed \$8,000/hp
<i>Concentrate return pipeline</i>	8 inch	ft	1,584	120	190,080	Assumed \$15/inch-ft
<i>HDDW well</i>						
Well construction	10 inch/2250 ft	ea	1	2,010,603	2,010,603	
<b>Total concentrate return</b>					<b>2,491,388</b>	
<b>Product Water Pump Station</b>	Two 85 hp pumps	ea	1	520,175	520,175	Assumed \$5,000/hp
<b>Total product water pump station</b>					<b>520,175</b>	
<b>Product Water Pipeline</b>	6 inch	ft	1,072	120	128,640	Assumed \$20/inch-ft
Product water pipeline					128,640	
<b>Total product water</b>					<b>648,815</b>	
<b>SUBTOTAL</b>						
					<b>11,041,104</b>	
Contingency					3,312,331	Assumed 30% contingency
<b>TOTAL CONSTRUCTION COST</b>						
					<b>14,353,435</b>	
Project implementation cost					3,588,359	Assumed 25% for surveying, geo-tech, engineering constr. Management , permitting and CCSD's stuff
<b>TOTAL CAPITAL COST</b>						
					<b>17,941,794</b>	

Cambria - Water Supply Alternative Concepts

**1. Shamel Park Seawater**

Operation and maintenance cost for 250 AF six month water production system

O&M Costing Item	Assumptions	Unit	Number	\$/unit	Cost, \$/Y ( 6 Mo Operation)
<b>Labor</b>					
Plant operation staff	1 FTE operators	ea	1	75,000	37,500
Plant maintenance staff	1 FTE maintenance staff	ea	1	75,000	37,500
<b>Total Labor</b>					<b>75,000</b>
<b>Energy</b>					
Seawater supply	Calculated based on pump power	kWh	112,082	0.15	16,812
SWRO membranes	Based on 7.6 kWh/1000g, TM 4.1.4, Table 7-6, pg. 7-7	kWh	618,205	0.15	92,731
UV disinfection	Base on 0.3kWh per 1,000 gallon, , TM 4.1.4, Table 7-6, pg. 7-7	kWh	24,403	0.15	3,660
Other plant power consumptions	5% of SWRO membranes	kWh	30,910	0.15	4,637
Concentrate return pump station	Calculated based on pump power		97,207	0.15	14,581
Product water pump station	Calculated based on pump power	kWh	278,302	0.15	41,745
Solar power system O&M Cost					
<b>Total Power</b>			<b>1,161,108</b>		<b>174,166</b>
Chemicals	\$0.31/1000 gallon, TM 4.1.4, Table 7-8, pg. 7-9	1,000 gallon	81,343	0.31	25,216
<b>Total Chemicals</b>					<b>25,216</b>
Consumables (Fe filter media, parts, cartages, RO membrane, UV lamps, ..)	\$0.3/1000 gallon, TM 4.1.4, Table 7-8, pg. 7-9	1,000 gallon	81,343	0.3	24,403
<b>Total Consumables</b>					<b>24,403</b>
<b>Total O&amp;M Cost</b>					<b>298,785</b>
15% Contingency					44,818
<b>TOTAL ANNUAL O&amp;M COSTS</b>					<b>343,603</b>

Cambria - Water Supply Alternative Concepts

1. Shamel Park Seawater

Life cycle cost for 250 AF six month water production system

Project Design Life	25
Interest Rate	3.5%
Project Implementation Cost	\$ 17,941,794
Annual O&M Cost	\$ 343,603
EUAC	\$ 1,432,204
Present Worth Life Cycle Cost	\$ 35,805,104
Future Cost of the Project	\$ 55,784,146
Cost of water, \$/AF	\$ 5,728.82

Formulas		
1	Capital Recovery (A/P) =	$i(1+i)^n$ $(1+i)^n - 1$
2	Uniform Series (F/A) = Compound Amount	$(1+i)^n - 1$ i
3	Single Payment (F/P) = Compound Amount	$(1+i)^n$
4	EUAC =	$P(A/P) + A(O\&M)$

Yr	A/P,%25	F/A,%25	F/P,%25	EUAC	Life Cycle Cost	O&M-F	Cap.-F	Total \$\$ Life of the Project
1	1.0350	1.0000	1.0350	\$ 18,913,360	\$ 18,913,360	\$ 343,603	\$ 18,569,757	\$ 18,913,360
2	0.5264	2.0350	1.0712	\$ 9,788,172	\$ 19,576,344	\$ 699,232	\$ 19,219,698	\$ 19,918,930
3	0.3569	3.1062	1.1087	\$ 6,747,643	\$ 20,242,928	\$ 1,067,309	\$ 19,892,388	\$ 20,959,696
4	0.2723	4.2149	1.1475	\$ 5,228,277	\$ 20,913,108	\$ 1,448,268	\$ 20,588,621	\$ 22,036,889
6	0.1877	6.5502	1.2293	\$ 3,710,707	\$ 22,264,245	\$ 2,250,653	\$ 22,055,046	\$ 24,305,698
7	0.1635	7.7794	1.2723	\$ 3,277,885	\$ 22,945,193	\$ 2,673,029	\$ 22,826,972	\$ 25,500,001
8	0.1455	9.0517	1.3168	\$ 2,953,715	\$ 23,629,721	\$ 3,110,188	\$ 23,625,916	\$ 26,736,104
9	0.1314	10.3685	1.3629	\$ 2,701,980	\$ 24,317,822	\$ 3,562,647	\$ 24,452,823	\$ 28,015,471
10	0.1202	11.7314	1.4106	\$ 2,500,949	\$ 25,009,489	\$ 4,030,943	\$ 25,308,672	\$ 29,339,615
11	0.1111	13.1420	1.4600	\$ 2,336,792	\$ 25,704,715	\$ 4,515,629	\$ 26,194,476	\$ 30,710,105
12	0.1035	14.6020	1.5111	\$ 2,200,291	\$ 26,403,490	\$ 5,017,280	\$ 27,111,282	\$ 32,128,562
13	0.0971	16.1130	1.5640	\$ 2,085,062	\$ 27,105,804	\$ 5,536,487	\$ 28,060,177	\$ 33,596,665
14	0.0916	17.6770	1.6187	\$ 1,986,546	\$ 27,811,648	\$ 6,073,868	\$ 29,042,283	\$ 35,116,151
15	0.0868	19.2957	1.6753	\$ 1,901,401	\$ 28,521,009	\$ 6,630,056	\$ 30,058,763	\$ 36,688,819
16	0.0827	20.9710	1.7340	\$ 1,827,117	\$ 29,233,877	\$ 7,205,711	\$ 31,110,820	\$ 38,316,531
17	0.0790	22.7050	1.7947	\$ 1,761,779	\$ 29,950,238	\$ 7,801,514	\$ 32,199,699	\$ 40,001,213
18	0.0758	24.4997	1.8575	\$ 1,703,893	\$ 30,670,078	\$ 8,418,170	\$ 33,326,688	\$ 41,744,858
19	0.0729	26.3572	1.9225	\$ 1,652,283	\$ 31,393,384	\$ 9,056,409	\$ 34,493,122	\$ 43,549,532
20	0.0704	28.2797	1.9898	\$ 1,606,007	\$ 32,120,141	\$ 9,716,987	\$ 35,700,382	\$ 45,417,368
21	0.0680	30.2695	2.0594	\$ 1,564,302	\$ 32,850,332	\$ 10,400,684	\$ 36,949,895	\$ 47,350,579
22	0.0659	32.3289	2.1315	\$ 1,526,543	\$ 33,583,942	\$ 11,108,312	\$ 38,243,141	\$ 49,351,453
23	0.0640	34.4604	2.2061	\$ 1,492,215	\$ 34,320,952	\$ 11,840,706	\$ 39,581,651	\$ 51,422,357
24	0.0623	36.6665	2.2833	\$ 1,460,889	\$ 35,061,346	\$ 12,598,733	\$ 40,967,009	\$ 53,565,742
25	0.0607	38.9499	2.3632	\$ 1,432,204	\$ 35,805,104	\$ 13,383,292	\$ 42,400,854	\$ 55,784,146

Cambria - Water Supply Alternative Concepts

**2. San Simeon Creek Off-stream Storage**

Construction cost estimates for 250 AF six month water production system

Cost Item		Diameter (in) Capacity (gpm) Depth (ft) volume (yds)	Unit	Number	Cost/Unit	Total	Comments
<b>Off Stream Reservoirs</b>							
<b>1</b>	<b>Dam and Reservoir 1</b>						
	Dam Structure	volume	cy	375,852	15	5,637,778	Assumed cost Of \$15/cy of built-in rock fill
	Upstream Screen	Area	sf	80,498	35	2,817,446	Based on \$900/cy of reinforced concrete
	Grout Line	Volume of grout	cy	2,458	1,000	2,458,333	Includes grouting and grout boreholes
	Spillways	Concrete volume	cy	586	1,200	703,616	Based on \$1,200/cy of reinforced concrete
	Outlet	Pipe length	ft	457	1,616	737,844	Based on \$30 per inch of pipe per foot
	Water intake	Pipe length	ft	415	317	131,574	Based on \$40 per inch of pipe per foot
	<b>Total Dam and Reservoir 1</b>					<b>12,486,590</b>	
<b>2</b>	<b>Dam and Reservoir 2</b>						
	Dam Structure	volume	cy	422,500	15	6,337,500	Assumed cost Of \$15/cy of built-in rock fill
	Upstream Screen	Area	sf	72,952	35	2,553,310	Based on \$900/cy of reinforced concrete
	Grout Line	Volume of grout	cy	2,438	1,000	2,437,500	Includes grouting and grout boreholes
	Spillways	Concrete volume	cy	581	1,200	697,653	Based on \$1,200/cy of reinforced concrete
	Outlet	Pipe length	ft	413	1,032	425,864	Based on \$30 per inch of pipe per foot
	Water intake	Pipe length	ft	375	317	118,892	Based on \$40 per inch of pipe per foot
	<b>Total Dam and Reservoir 2</b>					<b>12,570,719</b>	
<b>3</b>	<b>Dam and Reservoir 3</b>						
	Dam Structure	volume	cy	267,037	15	4,005,556	Assumed cost Of \$15/cy of built-in rock fill
	Upstream Screen	Area	sf	66,188	35	2,316,566	Based on \$900/cy of reinforced concrete
	Grout Line	Volume of grout	cy	1,717	1,000	1,716,667	Includes grouting and grout boreholes
	Spillways	Concrete volume	cy	409	1,200	491,339	Based on \$1,200/cy of reinforced concrete
	Outlet	Pipe length	ft	369	749	275,860	Based on \$30 per inch of pipe per foot
	Water intake	Pipe length	ft	335	317	106,210	Based on \$40 per inch of pipe per foot
	<b>Total Dam and Reservoir 3</b>					<b>8,912,197</b>	
	<b>Total Dams and Reservoirs</b>					<b>33,969,505</b>	
<b>Intake Water Wells</b>							
	Wells	Well depth	each	10	150,000	1,507,739	Assumed \$2,500/ft
	Wellhead	Pump horse power	hp	192	5,000	961,091	Assumed \$5,000 per hp
	<b>Total Intake Water Wells</b>					<b>2,468,830</b>	
<b>Water Pipeline</b>							
	Reservoir 1 well connecting pipes	Pipeline length	ft	1,720	120	206,400	Assumed \$10/ft per inch of pipe diameter
	Reservoir 2 well connecting pipes	Pipeline length	ft	1,100	80	88,000	Assumed \$10/ft per inch of pipe diameter
	Reservoir diversion pipeline	Pipeline length	ft	9,800	200	1,960,000	Assumed \$10/ft per inch of pipe diameter
	Water Treatment Plant Feed Water (Influent) Pip	Pipeline length	ft	3,500	60	210,000	Assumed \$10/ft per inch of pipe diameter

	<b>Total water pipeline</b>					<b>2,464,400</b>	
<b>Water Treatment Plant</b>	Plant capacity	gpd	442,080		4.0	2,298,816	Assumed \$4.0/gallon-day capacity for MF/UF WTP
	Pretreatment						
	Filtration						
	Chlorine Contact Tank (CCT) and product water pump station wet well						
	Disinfection						
	Waste stream						
	<b>Total treatment plant</b>					<b>2,988,461</b>	
	<b>Product Storage Reservoir</b>	<b>Storage volume</b>	<b>gallon</b>	<b>221,040</b>	<b>2</b>	<b>574,704</b>	
	<b>Total product water storage reservoir</b>					<b>574,704</b>	
<b>Product Water Pump Station</b>	Installed horse power	hp	61		5,000	303,216	Assumed \$5,000/hp
	<b>Total product water pump station</b>					<b>394,181</b>	
	<b>SUBTOTAL</b>					<b>42,860,081</b>	
	Contingency					12,858,024	Assumed 30% contingency
	<b>TOTAL CONSTRUCTION COST</b>					<b>55,718,106</b>	
	Project Implementation cost					13,929,526	Assumed 25% for surveying, geo-tech, engineering constr. Management , permitting and CCSD's stuff
	<b>TOTAL PROJECT CAPITAL COST</b>					<b>\$ 69,647,632</b>	

Cambria - Water Supply Alternative Concepts

**2. San Simeon Creek Off-stream Storage**

Operation and maintenance costs for 250 AF six month water production system

O&M Costing Item	Assumptions	Unit	Number	\$/unit	Cost, \$/Y (based on 6 Mo Operation)
<b>Labor</b>					
Plant operation staff	2 FTE operators	ea	1	75,000	75,000
Plant maintenance staff	2 FTE maintenance staff	ea	1	75,000	75,000
<b>Total Labor</b>					<b>150,000</b>
<b>Energy</b>					
Pumping water in storage reservoirs	Calculated based on 72 days pumping time	kWh	256,187	0.15	38,428
Microfiltration	0.33 kWh per 1000 g	kWh	26,843	0.15	4,026
UV Disinfection	0.27 kWh per 1000 g	kWh	21,963	0.15	3,294
Other WTP energy uses	25% of above consumption	kWh	12,201	0.15	1,830
Product water pump station	calculated	kWh	101,764	0.15	15,265
<b>Total Power</b>			<b>162,771</b>		<b>62,844</b>
Chemicals	\$0.25/1000 gallon	1,000 gallon	81,343	0.25	20,336
<b>Total Chemicals</b>					<b>20,336</b>
Consumables (UF replacement, parts, cartages, UV lamps, ..)	\$0.4/1000 gallon	1,000 gallon	81,343	0.55	44,738
<b>Total Consumables</b>					<b>44,738</b>
<b>Total O&amp;M Cost</b>					<b>277,918</b>
15% Contingency					41,688
<b>TOTAL ANNUAL O&amp;M COSTS</b>					<b>319,606</b>



Cambria - Water Supply Alternative Concepts

**2. San Simeon Creek Off-stream Storage**

Life cycle cost for 250 AF six month water production system

Project Design Life	25
Interest Rate	3.5%
Project Implementation Cost	\$ 69,647,632
Annual O&M Cost	\$ 319,606
EUAC	\$ 4,545,408
Present Worth Life Cycle Cost	\$ 113,635,212
Future Cost of the Project	\$ 177,043,008
Cost of water, \$/AF	\$ 18,181.63

Formulas	
1	Recovery = $\frac{i(1+i)^n}{(1+i)^n - 1}$
2	Uniform Series $\frac{(F/A) - i}{(1+i)^n - 1}$
3	Single Payment $(1+i)^n$
4	EUAC = $P(A/P) + A(O\&M)$

Yr	A/P,%25	F/A,%25	F/P,%25	EUAC	Life Cycle Cost	O&M-F	Cap.-F	Total \$\$ Life of the Project
1	1.0350	1.0000	1.0350	\$ 72,404,905	\$ 72,404,905	\$ 319,606	\$ 72,085,300	\$ 72,404,905
2	0.5264	2.0350	1.0712	\$ 36,982,153	\$ 73,964,307	\$ 650,397	\$ 74,608,285	\$ 75,258,682
3	0.3569	3.1062	1.1087	\$ 25,179,226	\$ 75,537,678	\$ 992,767	\$ 77,219,575	\$ 78,212,342
4	0.2723	4.2149	1.1475	\$ 19,281,253	\$ 77,125,011	\$ 1,347,119	\$ 79,922,260	\$ 81,269,379
6	0.1877	6.5502	1.2293	\$ 13,390,252	\$ 80,341,512	\$ 2,093,465	\$ 85,614,723	\$ 87,708,188
7	0.1635	7.7794	1.2723	\$ 11,710,092	\$ 81,970,646	\$ 2,486,342	\$ 88,611,238	\$ 91,097,580
8	0.1455	9.0517	1.3168	\$ 10,451,710	\$ 83,613,676	\$ 2,892,969	\$ 91,712,632	\$ 94,605,601
9	0.1314	10.3685	1.3629	\$ 9,474,509	\$ 85,270,577	\$ 3,313,829	\$ 94,922,574	\$ 98,236,403
10	0.1202	11.7314	1.4106	\$ 8,694,132	\$ 86,941,321	\$ 3,749,418	\$ 98,244,864	\$ 101,994,282
11	0.1111	13.1420	1.4600	\$ 8,056,898	\$ 88,625,877	\$ 4,200,254	\$ 101,683,434	\$ 105,883,688
12	0.1035	14.6020	1.5111	\$ 7,527,018	\$ 90,324,211	\$ 4,666,868	\$ 105,242,354	\$ 109,909,222
13	0.0971	16.1130	1.5640	\$ 7,079,714	\$ 92,036,286	\$ 5,149,814	\$ 108,925,837	\$ 114,075,651
14	0.0916	17.6770	1.6187	\$ 6,697,290	\$ 93,762,060	\$ 5,649,663	\$ 112,738,241	\$ 118,387,904
15	0.0868	19.2957	1.6753	\$ 6,366,766	\$ 95,501,491	\$ 6,167,007	\$ 116,684,080	\$ 122,851,086
16	0.0827	20.9710	1.7340	\$ 6,078,408	\$ 97,254,532	\$ 6,702,457	\$ 120,768,022	\$ 127,470,480
17	0.0790	22.7050	1.7947	\$ 5,824,773	\$ 99,021,133	\$ 7,256,649	\$ 124,994,903	\$ 132,251,552
18	0.0758	24.4997	1.8575	\$ 5,600,069	\$ 100,801,242	\$ 7,830,237	\$ 129,369,725	\$ 137,199,962
19	0.0729	26.3572	1.9225	\$ 5,399,727	\$ 102,594,804	\$ 8,423,901	\$ 133,897,665	\$ 142,321,566
20	0.0704	28.2797	1.9898	\$ 5,220,088	\$ 104,401,759	\$ 9,038,343	\$ 138,584,083	\$ 147,622,427
21	0.0680	30.2695	2.0594	\$ 5,058,193	\$ 106,222,048	\$ 9,674,291	\$ 143,434,526	\$ 153,108,817
22	0.0659	32.3289	2.1315	\$ 4,911,618	\$ 108,055,605	\$ 10,332,496	\$ 148,454,735	\$ 158,787,231
23	0.0640	34.4604	2.2061	\$ 4,778,364	\$ 109,902,365	\$ 11,013,739	\$ 153,650,650	\$ 164,664,390
24	0.0623	36.6665	2.2833	\$ 4,656,761	\$ 111,762,258	\$ 11,718,826	\$ 159,028,423	\$ 170,747,249
25	0.0607	38.9499	2.3632	\$ 4,545,408	\$ 113,635,212	\$ 12,448,590	\$ 164,594,418	\$ 177,043,008

Cambria - Water Supply Alternative Concepts

**3. Morro Bay Shared SWRO**

Construction cost for 250 AF six month water production system

Cost Item	Diameter (in) Capacity (gpm) Depth (ft) volume (yds)	Unit	Number	Cost/Unit	Total	Comments
<b>Seawater Intake</b>						
Beach wells						
Well construction	12 inch/80 ft	ea	3	320,000	960,000	Assumed super duplex SS at \$4,000/ft,
Well equipment		ea	3	80,000	240,000	Assumed \$1,000/ft
<b>Total beach wells</b>					<b>1,200,000</b>	
<b>Seawater Pipeline</b>	10 inch	ft	4,900	150	735,000	Assumed \$15/inch-ft
<b>Total seawater pipeline</b>					<b>735,000</b>	
<b>Seawater Pretreatment - Fe removal</b>						
<b>Total Fe removal</b>		ea	1	884,104	884,104	Based on quote from Filtronix for 400AF and reduced for 250 AF
<b>SWRO Treatment Plant</b>						
Pretreatment - Fe removal						
Pretreatment - particulate removal						
Pretreatment - chemical pretreatment						
SWRO						
RO booster pumps						
Energy recovery						
Product water post treatment/stabilization						
Disinfection						
<b>Total SWRO treatment plant</b>		EA	1	4,707,594	4,001,455	Based on TM 4.1.4 SWRO reduced by 15% for building and other already built facilities
<b>Concentrate return</b>						
Concentrate return pipeline	8 inch	ft	3,600	120	432,000	Assumed \$15/inch-ft
<b>Total concentrate return</b>					<b>432,000</b>	
<b>Product Water Pump Station</b>	210 hp	ea	2	632,590	1,265,179	Assumed \$5,000/hp
<b>Total product water pump station</b>					<b>1,265,179</b>	
<b>Product Water Pipeline</b>	6 inch	ft	97,680	90	8,791,200	Assumed \$15/inch-ft
Total Product water pipeline					8,791,200	
<b>SUBTOTAL</b>					<b>17,308,938</b>	
Contingency					5,192,681	Assumed 30% contingency
<b>TOTAL CONSTRUCTION COST</b>					<b>22,501,620</b>	
Project implementation cost					5,625,405	Assumed 25% for surveying, geo-tech, engineering constr. Management , permitting and CCSD's stuff
<b>TOTAL CAPITAL COST</b>					<b>28,127,025</b>	

Cambria - Water Supply Alternative Concepts

**3. Morro Bay Shared SWRO**

Operation and maintenance cost for 250 AF six month water production system

O&M Costing Item	Assumptions	Unit	Number	\$/unit	Cost, \$/Y (based on 6 Mo Operation)
<b>Labor</b>					
Plant operation staff	2 FTE operators	ea	1	75,000	37,500
Plant maintenance staff	2 FTE maintenance staff	ea	1	75,000	37,500
<b>Total Labor</b>					<b>75,000</b>
<b>Energy</b>					
Seawater supply	Calculated based on pump power	kWh	125,103	0.15	18,765
SWRO membranes	Based on 7.6 kWh/1000 gallon, TM 4.1.4, Table 7-6, pg.7-7	kWh	618,205	0.15	92,731
UV disinfection	Based on 0.3 kWh/1000 gallon, TM 4.1.4, Table 7-6, pg.7-7	kWh	39,744	0.15	5,962
Other plant power consumptions	10% of SWRO membranes	kWh	61,820	0.15	9,273
Product water pump station	Calculated based on pump power	kWh	415,611	0.15	62,342
<b>Total Power</b>					<b>189,073</b>
Chemicals	\$0.31/1000 gallon, TM 4.1.4, Table 7-8, pg. 7-9	1,000 gallon	81,343	0.25	20,336
<b>Total Chemicals</b>					<b>20,336</b>
Consumables (Fe filter media, parts, cartages, RO membrane, UV lamps, ..)	\$0.55/1000 gallon	1,000 gallon	81,343	0.55	44,738
<b>Total Consumables</b>					<b>44,738</b>
<b>Total O&amp;M Cost</b>					<b>329,147</b>
15% Contingency					49,372
<b>TOTAL ANNUAL O&amp;M COSTS</b>					<b>378,519</b>

Cambria - Water Supply Alternative Concepts

**3. Morro Bay Shared SWRO Alternative**

Life cycle cost for 250 AF six month water production system

Project Design Life	25
Interest Rate	3.5%
Project Implementation Cost	\$ 28,127,025
Annual O&M Cost	\$ 378,519
EUAC	\$ 2,085,099
Present Worth Life Cycle Cost	\$ 52,127,471
Future Cost of the Project	\$ 81,214,301
Cost of water, \$/AF	\$ 8,340.40

Formulas		
1	Capital Recovery (A/P) =	$i(1+i)^n$ $(1+i)^n - 1$
2	Uniform Series (F/A) = Compound Amount	$(1+i)^n - 1$ i
3	Single Payment (F/P) = Compound Amount	$(1+i)^n$
4	EUAC =	$P(A/P) + A(O&M)$

Yr	A/P,%25	F/A,%25	F/P,%25	EUAC	Life Cycle Cost	O&M-F	Cap.-F	al \$\$ Life of the Proj
1	1.0350	1.0000	1.0350	\$ 29,489,989	\$ 29,489,989	\$ 378,519	\$ 29,111,471	\$ 29,489,989
2	0.5264	2.0350	1.0712	\$ 15,184,598	\$ 30,369,197	\$ 770,286	\$ 30,130,372	\$ 30,900,658
3	0.3569	3.1062	1.1087	\$ 10,418,015	\$ 31,254,046	\$ 1,175,764	\$ 31,184,935	\$ 32,360,699
4	0.2723	4.2149	1.1475	\$ 8,036,133	\$ 32,144,533	\$ 1,595,435	\$ 32,276,408	\$ 33,871,843
6	0.1877	6.5502	1.2293	\$ 5,657,067	\$ 33,942,402	\$ 2,479,355	\$ 34,575,295	\$ 37,054,650
7	0.1635	7.7794	1.2723	\$ 4,978,539	\$ 34,849,771	\$ 2,944,651	\$ 35,785,430	\$ 38,730,082
8	0.1455	9.0517	1.3168	\$ 4,470,344	\$ 35,762,752	\$ 3,426,233	\$ 37,037,920	\$ 40,464,153
9	0.1314	10.3685	1.3629	\$ 4,075,704	\$ 36,681,334	\$ 3,924,670	\$ 38,334,248	\$ 42,258,917
10	0.1202	11.7314	1.4106	\$ 3,760,551	\$ 37,605,507	\$ 4,440,552	\$ 39,675,946	\$ 44,116,498
11	0.1111	13.1420	1.4600	\$ 3,503,205	\$ 38,535,257	\$ 4,974,490	\$ 41,064,604	\$ 46,039,094
12	0.1035	14.6020	1.5111	\$ 3,289,214	\$ 39,470,572	\$ 5,527,116	\$ 42,501,865	\$ 48,028,982
13	0.0971	16.1130	1.5640	\$ 3,108,572	\$ 40,411,436	\$ 6,099,084	\$ 43,989,431	\$ 50,088,515
14	0.0916	17.6770	1.6187	\$ 2,954,131	\$ 41,357,832	\$ 6,691,070	\$ 45,529,061	\$ 52,220,131
15	0.0868	19.2957	1.6753	\$ 2,820,650	\$ 42,309,744	\$ 7,303,777	\$ 47,122,578	\$ 54,426,355
16	0.0827	20.9710	1.7340	\$ 2,704,197	\$ 43,267,152	\$ 7,937,928	\$ 48,771,868	\$ 56,709,796
17	0.0790	22.7050	1.7947	\$ 2,601,767	\$ 44,230,037	\$ 8,594,274	\$ 50,478,884	\$ 59,073,157
18	0.0758	24.4997	1.8575	\$ 2,511,021	\$ 45,198,376	\$ 9,273,592	\$ 52,245,645	\$ 61,519,237
19	0.0729	26.3572	1.9225	\$ 2,430,113	\$ 46,172,148	\$ 9,976,687	\$ 54,074,242	\$ 64,050,929
20	0.0704	28.2797	1.9898	\$ 2,357,566	\$ 47,151,330	\$ 10,704,389	\$ 55,966,841	\$ 66,671,230
21	0.0680	30.2695	2.0594	\$ 2,292,185	\$ 48,135,895	\$ 11,457,562	\$ 57,925,680	\$ 69,383,242
22	0.0659	32.3289	2.1315	\$ 2,232,992	\$ 49,125,820	\$ 12,237,095	\$ 59,953,079	\$ 72,190,174
23	0.0640	34.4604	2.2061	\$ 2,179,177	\$ 50,121,076	\$ 13,043,912	\$ 62,051,437	\$ 75,095,349
24	0.0623	36.6665	2.2833	\$ 2,130,068	\$ 51,121,636	\$ 13,878,968	\$ 64,223,237	\$ 78,102,205
25	0.0607	38.9499	2.3632	\$ 2,085,099	\$ 52,127,471	\$ 14,743,250	\$ 66,471,050	\$ 81,214,301

Cambria - Water Supply Alternative Concepts

**4. Estero Bay Marine Terminal**

Construction costs for 250 AF six month water production system

Cost Item	Diameter (in) Capacity (gpm) Depth (ft) volume (yds)	Unit	Number	Cost/Unit	Total	Comments
<b>Seawater Intake</b>						
HDDW seawater intake well						
Well construction	12 inch/1,500 ft	ea	1	2,577,696	2,577,696	Based on TM 4.1.1A, pg. 4-62, item 4.4.5.1
Well equipment		ea	1	374,410	374,410	Based on TM 4.1.1A, pg. 4-62, item 4.4.5.1
<b>Total beach wells</b>					<b>2,952,107</b>	
<b>Seawater Pipeline</b>						
Total seawater pipeline	10 inch	ft	4,000	150	600,000	Assumed \$15/inch-ft
					<b>600,000</b>	
<b>SWRO Treatment Plant</b>						
Pretreatment - Fe removal						
Pretreatment - particulate removal						
Pretreatment - chemical pretreatment						
SWRO						
RO booster pumps						
Energy recovery						
Product water post treatment/stabilization						
Disinfection						
<b>Total SWRO treatment plant</b>		<b>EA</b>	<b>1</b>	<b>4,707,594</b>	<b>4,707,594</b>	\$8.67/gallon-day, based on TM 4.1.4 SWRO
<b>Concentrate return</b>						
Concentrate return pipeline	8 inch	ft	20,900	120	2,508,000	Assumed \$15/inch-ft
Concentrate return pump station	7.5 hp pumps	ea	1	120,000	120,000	Assumed \$8,000/hp
<b>Total concentrate return</b>					<b>2,628,000</b>	
<b>Product Water Pump Station</b>						
Total product water pump station	125 hp	ea	1	1,250,000	1,250,000	Assumed \$5,000/hp
					<b>1,250,000</b>	
<b>Product Water Pipeline</b>						
Total Product water pipeline	6 inch	ft	87,120	90	7,840,800	Assumed \$15/inch-ft
					<b>7,840,800</b>	
<b>SUBTOTAL</b>						
					<b>19,978,501</b>	
Contingency					5,993,550	Assumed 30% contingency
<b>TOTAL CONSTRUCTION COST</b>						
					<b>25,972,051</b>	
Project implementation cost					6,493,013	Assumed 25% for surveying, geo-tech, engineering constr. Management , permitting and CCSD's stuff
<b>TOTAL CAPITAL COST</b>						
					<b>32,465,064</b>	

Cambria - Water Supply Alternative Concepts

**4. Estero Bay Marine Terminal**

Operation and maintenance costs for 250 AF six month water production system

O&M Costing Item	Assumptions	Unit	Number	\$/unit	Cost, \$/Y (based on 6 Mo Operation)
<b>Labor</b>					
Plant operation staff	2 FTE operators	ea	1	75,000	37,500
Plant maintenance staff	2 FTE maintenance staff	ea	1	75,000	37,500
<b>Total Labor</b>					<b>75,000</b>
<b>Energy</b>					
Seawater supply	Calculated based on pump power	kWh	160,847	0.15	24,127
SWRO membranes	Based on 7.6 kWh/1000 gallon, TM 4.1.4, Table 7-6, pg.7-7	kWh	618,205	0.15	92,731
UV disinfection	Based on 0.3 kWh/1000 gallon, TM 4.1.4, Table 7-6, pg.7-7	kWh	24,403	0.15	3,660
Other plant power consumptions	10% of SWRO membranes	kWh	61,820	0.15	9,273
Concentrate return pump station	Calculated based on pump power	kWh	16,812	0.15	2,522
Product water pump station	Calculated based on pump power	kWh	408,076	0.15	61,211
<b>Total Power</b>					<b>193,525</b>
Chemicals	\$0.31/1000 gallon, TM 4.1.4, Table 7-8, pg. 7-9	1,000 gallon	81,343	0.31	25,216
<b>Total Chemicals</b>					<b>25,216</b>
Consumables (Fe filter media, parts, cartages, RO membrane, UV lamps, ..)	\$0.3/1000 gallon, TM 4.1.4, Table 7-8, pg. 7-9	1,000 gallon	81,343	0.3	24,403
<b>Total Consumables</b>					<b>24,403</b>
<b>Total O&amp;M Cost</b>					<b>318,144</b>
15% Contingency					47,722
<b>TOTAL ANNUAL O&amp;M COSTS</b>					<b>365,865</b>

Cambria - Water Supply Alternative Concepts

**4. Estero Bay Marine Terminal**

Life Cycle costs for 250 AF six month water production system

Project Design Life	25
Interest Rate	3.5%
Project Implementation Cost	\$ 32,465,064
Annual O&M Cost	\$ 365,865
EUAC	\$ 2,335,652
Present Worth Life Cycle Cost	\$ 58,391,290
Future Cost of the Project	\$ 90,973,295
<b>Cost of water, \$/AF</b>	<b>\$ 9,342.61</b>

Formulas		
1	Capital Recovery (A/P) =	$\frac{i(1+i)^n}{(1+i)^n - 1}$
2	Uniform Series (F/A) = Compound Amount	$\frac{(1+i)^n - 1}{i}$
3	Single Payment (F/P) = Compound Amount	$(1+i)^n$
4	EUAC =	$P(A/P) + A(O\&M)$

Yr	A/P,%25	F/A,%25	F/P,%25	EUAC	Life Cycle Cost	O&M-F	Cap.-F	\$ \$ Life of the Pro
1	1.0350	1.0000	1.0350	\$ 33,967,207	\$ 33,967,207	\$ 365,865	\$ 33,601,341	\$ 33,967,207
2	0.5264	2.0350	1.0712	\$ 17,455,491	\$ 34,910,982	\$ 744,536	\$ 34,777,388	\$ 35,521,924
3	0.3569	3.1062	1.1087	\$ 11,953,756	\$ 35,861,269	\$ 1,136,459	\$ 35,994,597	\$ 37,131,056
4	0.2723	4.2149	1.1475	\$ 9,204,516	\$ 36,818,063	\$ 1,542,101	\$ 37,254,408	\$ 38,796,509
6	0.1877	6.5502	1.2293	\$ 6,458,526	\$ 38,751,154	\$ 2,396,472	\$ 39,907,853	\$ 42,304,325
7	0.1635	7.7794	1.2723	\$ 5,675,348	\$ 39,727,433	\$ 2,846,214	\$ 41,304,628	\$ 44,150,842
8	0.1455	9.0517	1.3168	\$ 5,088,774	\$ 40,710,191	\$ 3,311,697	\$ 42,750,290	\$ 46,061,987
9	0.1314	10.3685	1.3629	\$ 4,633,268	\$ 41,699,413	\$ 3,793,471	\$ 44,246,550	\$ 48,040,021
10	0.1202	11.7314	1.4106	\$ 4,269,509	\$ 42,695,089	\$ 4,292,108	\$ 45,795,179	\$ 50,087,287
11	0.1111	13.1420	1.4600	\$ 3,972,473	\$ 43,697,202	\$ 4,808,197	\$ 47,398,011	\$ 52,206,207
12	0.1035	14.6020	1.5111	\$ 3,725,478	\$ 44,705,738	\$ 5,342,349	\$ 49,056,941	\$ 54,399,290
13	0.0971	16.1130	1.5640	\$ 3,516,975	\$ 45,720,679	\$ 5,895,196	\$ 50,773,934	\$ 56,669,130
14	0.0916	17.6770	1.6187	\$ 3,338,715	\$ 46,742,006	\$ 6,467,393	\$ 52,551,022	\$ 59,018,415
15	0.0868	19.2957	1.6753	\$ 3,184,647	\$ 47,769,699	\$ 7,059,617	\$ 54,390,307	\$ 61,449,924
16	0.0827	20.9710	1.7340	\$ 3,050,233	\$ 48,803,736	\$ 7,672,569	\$ 56,293,968	\$ 63,966,537
17	0.0790	22.7050	1.7947	\$ 2,932,005	\$ 49,844,093	\$ 8,306,974	\$ 58,264,257	\$ 66,571,231
18	0.0758	24.4997	1.8575	\$ 2,827,264	\$ 50,890,748	\$ 8,963,583	\$ 60,303,506	\$ 69,267,089
19	0.0729	26.3572	1.9225	\$ 2,733,877	\$ 51,943,672	\$ 9,643,174	\$ 62,414,129	\$ 72,057,302
20	0.0704	28.2797	1.9898	\$ 2,650,142	\$ 53,002,840	\$ 10,346,550	\$ 64,598,623	\$ 74,945,173
21	0.0680	30.2695	2.0594	\$ 2,574,677	\$ 54,068,224	\$ 11,074,544	\$ 66,859,575	\$ 77,934,119
22	0.0659	32.3289	2.1315	\$ 2,506,354	\$ 55,139,792	\$ 11,828,019	\$ 69,199,660	\$ 81,027,679
23	0.0640	34.4604	2.2061	\$ 2,444,240	\$ 56,217,514	\$ 12,607,864	\$ 71,621,648	\$ 84,229,513
24	0.0623	36.6665	2.2833	\$ 2,387,557	\$ 57,301,358	\$ 13,415,005	\$ 74,128,406	\$ 87,543,411
25	0.0607	38.9499	2.3632	\$ 2,335,652	\$ 58,391,290	\$ 14,250,395	\$ 76,722,900	\$ 90,973,295

Cambria - Water Supply Alternative Concepts

**5. San Simeon Creek Road Brackish Water**

Construction cost for 250 AF six month water production system

<b>FACILITY</b>	<b>Diameter (in) Capacity (gpm) Depth (ft)</b>	<b>Unit</b>	<b>Number</b>	<b>Unit</b>	<b>Cost/Unit</b>	<b>Total</b>
<b>AWTF Extraction Facilities</b>						
AWTF Extraction Well Facilities	120	ft	3	ea	\$198,000	\$594,000
AWTF Extraction Wellhead Facilities	11	Hp	3	ea	\$88,000	\$264,000
AWTF Influent Pipeline	10	in	650	lf	\$150	\$97,500
<b>subtotal</b>						<b>\$955,500</b>
<b>Advanced Water Treatment Plant (AWTF)</b>						
MF/UF Pretreatment - particulate removal	1	LS	2	ea	\$15,000	\$30,000
MF/UF Pretreatment - chemical addition	1	LS	2	ea	\$30,000	\$60,000
MF/UF System	245	gpm	2	train	\$705,600	\$1,411,200
MF Break tank	15,000	gal	2	ea	\$45,000	\$90,000
RO Transfer booster pumps	8	Hp	2	ea	\$65,993	\$131,987
RO Pretreatment - chemical addition	1	LS	2	ea	\$30,000	\$60,000
RO Pretreatment - particulate removal	1	LS	2	ea	\$15,000	\$30,000
RO System	210	gpm	2	ea	\$604,800	\$1,209,600
RO Feed pumps	40	Hp	2	ea	\$40,000	\$80,000
UV Oxidation System	210	gpm	2	ea	\$241,920	\$483,840
Product water post treatment/stabilization	1	LS	3	ea	\$30,000	\$90,000
AWTF Lagoon Fresh Water Pump Station	2	Hp	2	ea	\$18,855	\$37,710
Recharge Pump Station	8	Hp	2	ea	\$60,337	\$120,673
Concentrate Pump Station	2	Hp	2	ea	\$18,879	\$37,757
Civil/Yard Piping Allowance	12	%	1	LS	\$228,301	\$228,301
Electrical Allowance	15	%	1	LS	\$285,376	\$285,376
Instrumentation Allowance	7	%	1	LS	\$133,175	\$133,175
<b>subtotal</b>						<b>\$4,519,619</b>
<b>Lagoon Fresh Water Barrier Facilities</b>						
Lagoon Fresh Water Injection Wells	60	ea	3	ea	\$108,000	\$324,000
Lagoon Fresh Water Wellhead Facilities	1	LS	3	ea	\$50,000	\$150,000
Lagoon Fresh Water Pipeline	4	in	3,900	LF	\$60	\$234,000
<b>subtotal</b>						<b>\$708,000</b>
<b>Recharge Facilities</b>						



Recharge Injection Wells	140	ea	4	ea	\$210,000	\$840,000
Recharge Wellhead Facilities	1	LS	4	ea	\$50,000	\$200,000
Recharge Well Pipeline	8	in	4,800	LF	\$120	\$576,000
<b>subtotal</b>						<b>\$1,616,000</b>
<b>Concentrate Disposal Facilities</b>						
Concentrate Injection Wells	150	ea	2	ea	\$270,000	\$540,000
Concentrate Wellhead Facilities	1	LS	2	ea	\$50,000	\$100,000
Concentrate Injection Well Pipelines	6	in	11,000	LF	\$90	\$990,000
<b>subtotal</b>						<b>\$1,630,000</b>
<b>SUBTOTAL</b>						<b>\$9,429,119</b>
Contingency	30	%				\$2,828,736
<b>TOTAL CONSTRUCTION COST</b>						<b>\$12,257,855</b>
Project implementation cost	25	%				\$3,064,464
<b>TOTAL CAPITAL COST</b>						<b>\$15,322,319</b>

Cambria - Water Supply Alternative Concepts

**5. San Simeon Creek Road Brackish Water**

Operation and maintenance cost for 250 AF six month water production system

O&M Costing Item	Description	Unit	Number	Unit	\$/unit	Cost, \$/Y (based on 6 Mo Operation w/o Solar)
<b>Labor</b>						
Plant operation staff	FTE operators	ea	2	ea	\$75,000	\$75,000
Plant maintenance staff	FTE maintenance staff	ea	2	ea	\$75,000	\$75,000
<b>Total Labor</b>						<b>\$150,000</b>
<b>Energy</b>						
AWTF Extraction Wellhead Facilities	22	Hp	78,778	Kwh	\$0.15	\$11,817
RO Transfer booster pumps	8	Hp	29,539	Kwh	\$0.15	\$4,431
RO Feed pumps	80	Hp	286,464	Kwh	\$0.15	\$42,970
UV Oxidation System	74	Kw	319,680	Kwh	\$0.15	\$47,952
AWTF Lagoon Fresh Water Pump Station	2	Hp	8,440	Kwh	\$0.15	\$1,266
Recharge Pump Station	8	Hp	27,007	Kwh	\$0.15	\$4,051
Concentrate Pump Station	2	Hp	8,450	Kwh	\$0.15	\$1,268
Solar Power System O&M Costs						
<b>Total Power</b>			<b>758,357</b>			<b>\$113,753</b>
MF/UF Pretreatment	Ammonia/Sodium Hypochlorite		108,864	1,000 gallon	\$0.03	\$3,266
RO Pretreatment	Sulfuric acid/Threshold Inhibitor		108,864	1,000 gallon	\$0.10	\$10,886
UV Oxidation	Hydrogen Peroxide		108,864	1,000 gallon	\$0.02	\$2,177
Post treatment Stabilization	Sodium Hydroxide/Calcium Chloride		108,864	1,000 gallon	\$0.01	\$1,089
Cleaning Chemicals	Various		108,864	1,000 gallon	\$0.03	\$3,266
<b>Total Chemicals</b>						<b>\$20,684</b>
Consumables	MF membranes, filter cartridges, RO membrane, UV lamps		108,864	1,000 gallon	\$0.25	\$27,216
<b>Total Consumables</b>						<b>\$27,216</b>
Maintenance	MF membranes, filter cartridges, RO membrane, UV lamps, misc repairs		108,864	1,000 gallon	\$0.20	\$21,773
<b>Total Maintenance</b>						<b>\$21,773</b>
<b>Total O&amp;M Cost</b>						<b>\$333,426</b>
Contingency					15%	\$50,014
<b>TOTAL ANNUAL O&amp;M COSTS</b>						<b>\$383,440</b>

Cambria - Water Supply Alternative Concepts

**5. San Simeon Creek Road Brackish Water**

Life cycle cost for 250 AF six month water production system

Project Design Life	25
Interest Rate	3.5%
Project Implementation Cost	\$ 15,322,319
Annual O&M Cost	\$ 383,440
EUAC	\$ 1,313,107
Present Worth Life Cycle Cost	\$ 32,827,683
Future Cost of the Project	\$ 51,145,342
Cost of water, \$/AF	\$ 5,252.43

Formulas		
1	Capital Recovery (A/P) =	$i(1+i)^n$ $(1+i)^n - 1$
2	Uniform Series (F/A) = Compound Amount	$(1+i)^n - 1$ i
3	Single Payment (F/P) = Compound Amount	$(1+i)^n$
4	EUAC =	$P(A/P) + A(O&M)$

Yr	A/P,%25	F/A,%25	F/P,%25	EUAC	Life Cycle Cost	O&M-F	Cap.-F	al \$\$ Life of the Proj
1	1.0350	1.0000	1.0350	\$ 16,242,040	\$ 16,242,040	\$ 383,440	\$ 15,858,600	\$ 16,242,040
2	0.5264	2.0350	1.0712	\$ 8,449,117	\$ 16,898,233	\$ 780,301	\$ 16,413,651	\$ 17,193,952
3	0.3569	3.1062	1.1087	\$ 5,852,500	\$ 17,557,499	\$ 1,191,052	\$ 16,988,129	\$ 18,179,181
4	0.2723	4.2149	1.1475	\$ 4,554,959	\$ 18,219,837	\$ 1,616,179	\$ 17,582,713	\$ 19,198,893
6	0.1877	6.5502	1.2293	\$ 3,258,953	\$ 19,553,715	\$ 2,511,593	\$ 18,835,042	\$ 21,346,635
7	0.1635	7.7794	1.2723	\$ 2,889,321	\$ 20,225,249	\$ 2,982,939	\$ 19,494,268	\$ 22,477,208
8	0.1455	9.0517	1.3168	\$ 2,612,480	\$ 20,899,840	\$ 3,470,782	\$ 20,176,568	\$ 23,647,350
9	0.1314	10.3685	1.3629	\$ 2,397,498	\$ 21,577,482	\$ 3,975,700	\$ 20,882,748	\$ 24,858,448
10	0.1202	11.7314	1.4106	\$ 2,225,817	\$ 22,258,170	\$ 4,498,290	\$ 21,613,644	\$ 26,111,934
11	0.1111	13.1420	1.4600	\$ 2,085,627	\$ 22,941,896	\$ 5,039,171	\$ 22,370,121	\$ 27,409,292
12	0.1035	14.6020	1.5111	\$ 1,969,054	\$ 23,628,654	\$ 5,598,982	\$ 23,153,076	\$ 28,752,058
13	0.0971	16.1130	1.5640	\$ 1,870,649	\$ 24,318,434	\$ 6,178,387	\$ 23,963,433	\$ 30,141,820
14	0.0916	17.6770	1.6187	\$ 1,786,516	\$ 25,011,228	\$ 6,778,071	\$ 24,802,154	\$ 31,580,224
15	0.0868	19.2957	1.6753	\$ 1,713,802	\$ 25,707,027	\$ 7,398,744	\$ 25,670,229	\$ 33,068,973
16	0.0827	20.9710	1.7340	\$ 1,650,364	\$ 26,405,820	\$ 8,041,140	\$ 26,568,687	\$ 34,609,827
17	0.0790	22.7050	1.7947	\$ 1,594,564	\$ 27,107,596	\$ 8,706,020	\$ 27,498,591	\$ 36,204,611
18	0.0758	24.4997	1.8575	\$ 1,545,130	\$ 27,812,344	\$ 9,394,172	\$ 28,461,042	\$ 37,855,213
19	0.0729	26.3572	1.9225	\$ 1,501,055	\$ 28,520,051	\$ 10,106,408	\$ 29,457,178	\$ 39,563,586
20	0.0704	28.2797	1.9898	\$ 1,461,535	\$ 29,230,705	\$ 10,843,573	\$ 30,488,179	\$ 41,331,752
21	0.0680	30.2695	2.0594	\$ 1,425,919	\$ 29,944,292	\$ 11,606,538	\$ 31,555,266	\$ 43,161,804
22	0.0659	32.3289	2.1315	\$ 1,393,673	\$ 30,660,799	\$ 12,396,207	\$ 32,659,700	\$ 45,055,907
23	0.0640	34.4604	2.2061	\$ 1,364,357	\$ 31,380,210	\$ 13,213,515	\$ 33,802,789	\$ 47,016,304
24	0.0623	36.6665	2.2833	\$ 1,337,605	\$ 32,102,510	\$ 14,059,428	\$ 34,985,887	\$ 49,045,316
25	0.0607	38.9499	2.3632	\$ 1,313,107	\$ 32,827,683	\$ 14,934,949	\$ 36,210,393	\$ 51,145,342

Cambria - Water Supply Alternative study

**6. Hard Rock Aquifer Storage and Recovery**

Construction cost for 250 AF six month water production system

Cost Item	Diameter (in) Capacity (gpm) Depth (ft) volume (yds)	Unit	Number	Cost/Unit	Total	Comments
Well SR4 refurbishment		#	1	\$ 112,500	\$ 112,500	Assumed 50% of new well
Water Conveyance Pipelines: SR4-Hard Rock-RO plant site	8" diameter	ft	20,000	\$ 116	\$ 2,327,389	\$15/inch-ft
Aquifer Storage and recovery wells	10" diameter/1000 ft deep	#	42	\$ 900,000	\$ 37,864,286	Assumed \$900/ft
Recovered water well pump	8 HP/well, 42 wells	HP	334	\$ 8,000	\$ 2,670,596	Assumed \$8,000 /HP
Water Treatment Plant	Capacity	GPD	442,080	\$ 5	\$ 2,210,400	\$5/gpd for BWRO
Product water pump station	92 HP pump station	HP	57	\$ 8,000	\$ 454,226	Assumed \$8,000 /HP
Brine pipeline	6" diameter	ft	5,000	\$ 120	\$ 600,000	\$20/inch-ft
Brine pump station	5 HP pump station	HP	5	\$ 8,000	\$ 40,000	Assumed \$8,000 /HP
<b>SUBTOTAL</b>					<b>46,279,396</b>	
Contingency					13,883,819	Assumed 30% contingency
<b>TOTAL CONSTRUCTION COST</b>					<b>60,163,215</b>	
Project implementation cost					15,040,804	Assumed 25% for surveying, geo-tech, engineering constr. Management , permitting and CCSD's stuff
<b>TOTAL CAPITAL COST</b>					<b>75,204,019</b>	

Cambria - Water Supply Alternative Concepts

**6. Hard Rock Aquifer Storage and Recovery**

Operation and maintenance cost for 250 AF six month water production system

O&M Costing Item	Assumptions	Unit	Number	\$/unit	Cost, \$/Y (based on 6 Mo Operation)
<b>Labor</b>					
Plant operation staff	2 FTE operators	ea	1	75,000	37,500
Plant maintenance staff	2 FTE maintenance staff	ea	1	75,000	37,500
<b>Total Labor</b>					<b>75,000</b>
<b>Energy</b>					
SR4 Well		kwh	279,225	0.15	\$ 41,884
Recovered water well pump		kwh	1,096,614	0.15	\$ 164,492
Water Treatment Plant	Assumed 3.5kWh/1000 gallons	kwh	919,800	0.15	\$ 137,970
Product water pump station		kwh	186,516	0.15	\$ 27,977
Brine pump station		kwh	2,048	0.15	\$ 307
<b>Total Power</b>			<b>2,484,203</b>		<b>\$ 372,630</b>
Chemicals	\$0.25/1000 gallon	1,000 gallon	32,850	0.25	8,213
<b>Total Chemicals</b>					<b>8,213</b>
Consumables (Fe filter media, parts, cartages, UV lamps, ..)	\$0.35/1000 gallon	1,000 gallon	45,990	0.35	16,097
<b>Total Consumables</b>					<b>16,097</b>
<b>Total O&amp;M Cost</b>					<b>471,939</b>
15% Contingency					70,791
<b>TOTAL ANNUAL O&amp;M COSTS</b>					<b>542,730</b>

Cambria - Water Supply Alternative Concepts

**Hard Rock ASR Alternative**

Life cycle cost for 250 AF six month water production system w/o solar power

Project Design Life	25
Interest Rate	3.5%
Project Implementation Cost	\$ 75,204,019
Annual O&M Cost	\$ 542,730
EUAC	\$ 5,105,662
Present Worth Life Cycle Cost	\$ 127,641,541
Future Cost of the Project	\$ 198,864,789
Cost of water, \$/AF	\$ 20,422.65

Formulas		
1	Capital Recovery (A/P) =	$\frac{i(1+i)^n}{(1+i)^n - 1}$
2	Uniform Series (F/A) = Compound Amount	$\frac{(1+i)^n - 1}{i}$
3	Single Payment (F/P) = Compound Amount	$(1+i)^n$
4	EUAC =	$P(A/P) + A(O\&M)$

Yr	A/P,%25	F/A,%25	F/P,%25	EUAC	Life Cycle Cost	O&M-F	Cap.-F	tal \$\$ Life of the Project
1	1.0350	1.0000	1.0350	\$ 78,378,890	\$ 78,378,890	\$ 542,730	\$ 77,836,159	\$ 78,378,890
2	0.5264	2.0350	1.0712	\$ 40,130,163	\$ 80,260,326	\$ 1,104,456	\$ 80,560,425	\$ 81,664,881
3	0.3569	3.1062	1.1087	\$ 27,385,615	\$ 82,156,845	\$ 1,685,843	\$ 83,380,040	\$ 85,065,882
4	0.2723	4.2149	1.1475	\$ 21,017,110	\$ 84,068,441	\$ 2,287,577	\$ 86,298,341	\$ 88,585,919
6	0.1877	6.5502	1.2293	\$ 14,656,134	\$ 87,936,803	\$ 3,554,966	\$ 92,444,941	\$ 95,999,907
7	0.1635	7.7794	1.2723	\$ 12,841,934	\$ 89,893,535	\$ 4,222,120	\$ 95,680,514	\$ 99,902,634
8	0.1455	9.0517	1.3168	\$ 11,483,159	\$ 91,865,270	\$ 4,912,625	\$ 99,029,332	\$ 103,941,956
9	0.1314	10.3685	1.3629	\$ 10,427,998	\$ 93,851,984	\$ 5,627,297	\$ 102,495,358	\$ 108,122,655
10	0.1202	11.7314	1.4106	\$ 9,585,364	\$ 95,853,644	\$ 6,366,983	\$ 106,082,696	\$ 112,449,679
11	0.1111	13.1420	1.4600	\$ 8,897,293	\$ 97,870,219	\$ 7,132,558	\$ 109,795,590	\$ 116,928,148
12	0.1035	14.6020	1.5111	\$ 8,325,139	\$ 99,901,670	\$ 7,924,928	\$ 113,638,436	\$ 121,563,363
13	0.0971	16.1130	1.5640	\$ 7,842,151	\$ 101,947,959	\$ 8,745,030	\$ 117,615,781	\$ 126,360,811
14	0.0916	17.6770	1.6187	\$ 7,429,217	\$ 104,009,040	\$ 9,593,837	\$ 121,732,333	\$ 131,326,170
15	0.0868	19.2957	1.6753	\$ 7,072,324	\$ 106,084,867	\$ 10,472,351	\$ 125,992,965	\$ 136,465,316
16	0.0827	20.9710	1.7340	\$ 6,760,962	\$ 108,175,390	\$ 11,381,614	\$ 130,402,719	\$ 141,784,333
17	0.0790	22.7050	1.7947	\$ 6,487,091	\$ 110,280,555	\$ 12,322,701	\$ 134,966,814	\$ 147,289,515
18	0.0758	24.4997	1.8575	\$ 6,244,461	\$ 112,400,306	\$ 13,296,726	\$ 139,690,652	\$ 152,987,378
19	0.0729	26.3572	1.9225	\$ 6,028,136	\$ 114,534,582	\$ 14,304,841	\$ 144,579,825	\$ 158,884,666
20	0.0704	28.2797	1.9898	\$ 5,834,166	\$ 116,683,321	\$ 15,348,241	\$ 149,640,119	\$ 164,988,360
21	0.0680	30.2695	2.0594	\$ 5,659,355	\$ 118,846,457	\$ 16,428,160	\$ 154,877,523	\$ 171,305,683
22	0.0659	32.3289	2.1315	\$ 5,501,087	\$ 121,023,920	\$ 17,545,876	\$ 160,298,236	\$ 177,844,112
23	0.0640	34.4604	2.2061	\$ 5,357,202	\$ 123,215,639	\$ 18,702,712	\$ 165,908,675	\$ 184,611,387
24	0.0623	36.6665	2.2833	\$ 5,225,897	\$ 125,421,538	\$ 19,900,037	\$ 171,715,478	\$ 191,615,515
25	0.0607	38.9499	2.3632	\$ 5,105,662	\$ 127,641,541	\$ 21,139,269	\$ 177,725,520	\$ 198,864,789

Cambria - Water Supply Alternative Concepts

**7. Whale Rock Reservoir**

Construction cost for 250 AF six month water production system

Cost Item	Diameter (in) Capacity (gym) Depth (ft) volume (yds)	Unit	Number	Cost/Unit	Total	Comments
Additional intake well in S. Rosa Creek	400	#	0	400,000	-	No additional water intake wells are required for 250 AF
Water conveyance facilities						
Cambria Pump Station	Horse power	110	2	880,000	1,760,000	Assumed \$8,000 per hp installed
Cambria - Cayucos water conveyance pipeline	inch and foot	10	87,120	150	13,068,000	Assumed \$15 per inch of pie diameter per foot
Pipeline from water conveyance pipeline to Whale Rock reservoir	inch and foot	10	3,300	150	495,000	Assumed \$15 per inch of pie diameter per foot
<b>Total water conveyance facilities</b>					<b>15,323,000</b>	
Surface water treatment plant at Whale Rock Reservoir		gpd	442,080	4.0	1,768,320	\$4 /gallon-day capacity
Product water storage reservoir (in Cambria)	697,346	gallon	1	2	1,394,692	\$2/gallon of storage volume
Product water transfer pump station at Whale Rock WTP	Horse power	30	2	240,000	480,000	Assumed \$5,000/hp
<b>SUBTOTAL</b>					<b>18,966,012</b>	
Contingency					5,689,804	Assumed 30% contingency
<b>TOTAL CONSTRUCTION COST</b>					<b>24,655,815</b>	
Project implementation cost					6,163,954	Assumed 25% for surveying, geo-tech, engineering constr. Management , permitting and CCSD's stuff
<b>TOTAL CAPITAL COST</b>					<b>30,819,769</b>	

Cambria - Water Supply Alternative Concepts

**7. Whale Rock Reservoir**

Operation and maintenance cost for 250 AF six month water production system - Option A without Lake Nacimiento

O&M Costing Item	Assumptions	Unit	Number	\$/unit	Cost, \$/Y (based on 6 Mo Operation)
Labor					
Plant operation staff	1 FTE operators	ea	1	75,000	37,500
Plant maintenance staff	1 FTE maintenance staff	ea	1	75,000	37,500
<b>Total Labor</b>					<b>75,000</b>
Energy					
Pumping water from S. Simeon and S. Rosa Wells to Cambria PS	969 gpm over 73 days at 0.2% head loss through distribution(30,000 ft from S. Simeon wells and 8, 000 ft from S. Rosa wells)	kWh	28,032	0.15	4,205
Cambria Pump Station	Calculated based on pumping power requirements	kWh	151,947	0.15	22,792
Surface water treatment plant at Whale Rock Reservoir	0.6 kwh per 1000 g	kWh	#####	0.15	7,261
Other WTP energy uses	20% of above consumption	kWh	40,071	0.15	6,011
Product water transfer pump station at Whale Rock WTP	Calculated based on pumping power requirements	kWh	96,910	0.15	14,537
<b>Total Power</b>			<b>185,389</b>		<b>54,805</b>
Chemicals	\$0.25/1000 gallon	1,000 gallon	131,400	0.25	32,850
<b>Total Chemicals</b>					<b>32,850</b>
Consumables (Fe filter media, parts, cartages, UV lamps, ...)	\$0.35/1000 gallon	1,000 gallon	131,400	0.35	45,990
<b>Total Consumables</b>					<b>45,990</b>
<b>Total O&amp;M Cost</b>					<b>208,645</b>
15% Contingency					31,297
<b>TOTAL ANNUAL O&amp;M COSTS</b>					<b>239,942</b>



Cambria - Water Supply Alternative Concepts

**7. Whale Rock Reservoir**

Life cycle cost for 250 AF six month water production system - Option A without Lake Nacimiento

Project Design Life	25
Interest Rate	3.5%
Project Implementation Cost	\$ 30,819,769
Annual O&M Cost	\$ 239,942
EUAC	\$ 2,109,902
Present Worth Life Cycle Cost	\$ 52,747,543
Future Cost of the Project	\$ 82,180,369

Formulas		
1	Capital Recovery (A/P) =	$\frac{i(1+i)^n}{(1+i)^n - 1}$
2	Uniform Series (F/A) = Compound Amount	$\frac{(1+i)^n - 1}{i}$
3	Single Payment (F/P) = Compound Amount	$(1+i)^n$
4	EUAC =	$P(A/P) + A(O\&M)$

Yr	A/P,%25	F/A,%25	F/P,%25	EUAC	Life Cycle Cost	O&M-F	Cap.-F	tal \$\$ Life of the Proje
1	1.0350	1.0000	1.0350	\$ 32,138,403	\$ 32,138,403	\$ 239,942	\$ 31,898,461	\$ 32,138,403
2	0.5264	2.0350	1.0712	\$ 16,463,484	\$ 32,926,967	\$ 488,282	\$ 33,014,907	\$ 33,503,189
3	0.3569	3.1062	1.1087	\$ 11,240,571	\$ 33,721,713	\$ 745,314	\$ 34,170,429	\$ 34,915,743
4	0.2723	4.2149	1.1475	\$ 8,630,659	\$ 34,522,637	\$ 1,011,342	\$ 35,366,394	\$ 36,377,736
6	0.1877	6.5502	1.2293	\$ 6,023,833	\$ 36,142,997	\$ 1,571,656	\$ 37,885,365	\$ 39,457,022
7	0.1635	7.7794	1.2723	\$ 5,280,345	\$ 36,962,418	\$ 1,866,606	\$ 39,211,353	\$ 41,077,959
8	0.1455	9.0517	1.3168	\$ 4,723,499	\$ 37,787,989	\$ 2,171,879	\$ 40,583,751	\$ 42,755,630
9	0.1314	10.3685	1.3629	\$ 4,291,077	\$ 38,619,697	\$ 2,487,837	\$ 42,004,182	\$ 44,492,019
10	0.1202	11.7314	1.4106	\$ 3,945,753	\$ 39,457,531	\$ 2,814,853	\$ 43,474,328	\$ 46,289,181
11	0.1111	13.1420	1.4600	\$ 3,663,771	\$ 40,301,477	\$ 3,153,315	\$ 44,995,930	\$ 48,149,245
12	0.1035	14.6020	1.5111	\$ 3,429,293	\$ 41,151,520	\$ 3,503,623	\$ 46,570,787	\$ 50,074,410
13	0.0971	16.1130	1.5640	\$ 3,231,357	\$ 42,007,644	\$ 3,866,192	\$ 48,200,765	\$ 52,066,957
14	0.0916	17.6770	1.6187	\$ 3,062,131	\$ 42,869,829	\$ 4,241,450	\$ 49,887,791	\$ 54,129,242
15	0.0868	19.2957	1.6753	\$ 2,915,871	\$ 43,738,058	\$ 4,629,843	\$ 51,633,864	\$ 56,263,707
16	0.0827	20.9710	1.7340	\$ 2,788,269	\$ 44,612,309	\$ 5,031,830	\$ 53,441,049	\$ 58,472,879
17	0.0790	22.7050	1.7947	\$ 2,676,033	\$ 45,492,561	\$ 5,447,886	\$ 55,311,486	\$ 60,759,372
18	0.0758	24.4997	1.8575	\$ 2,576,599	\$ 46,378,791	\$ 5,878,503	\$ 57,247,388	\$ 63,125,892
19	0.0729	26.3572	1.9225	\$ 2,487,946	\$ 47,270,973	\$ 6,324,193	\$ 59,251,047	\$ 65,575,240
20	0.0704	28.2797	1.9898	\$ 2,408,454	\$ 48,169,082	\$ 6,785,482	\$ 61,324,833	\$ 68,110,315
21	0.0680	30.2695	2.0594	\$ 2,336,814	\$ 49,073,091	\$ 7,262,916	\$ 63,471,203	\$ 70,734,118
22	0.0659	32.3289	2.1315	\$ 2,271,953	\$ 49,982,971	\$ 7,757,060	\$ 65,692,695	\$ 73,449,754
23	0.0640	34.4604	2.2061	\$ 2,212,987	\$ 50,898,694	\$ 8,268,499	\$ 67,991,939	\$ 76,260,438
24	0.0623	36.6665	2.2833	\$ 2,159,176	\$ 51,820,229	\$ 8,797,838	\$ 70,371,657	\$ 79,169,495
25	0.0607	38.9499	2.3632	\$ 2,109,902	\$ 52,747,543	\$ 9,345,704	\$ 72,834,665	\$ 82,180,369

Cambria - Water Supply Alternative study

**8. San Simeon CSD Recycled Water Construction Cost**

Construction cost for 250 AF six month water production system

Cost Item	Unit	Value	Cost Unit	\$/Cost unit	Cost, \$	Comments
<b>EQ basin</b>	<b>gallon</b>	<b>87,500</b>	<b>\$/Gallon</b>	<b>2</b>	<b>\$ 175,000</b>	
<b>Lift station at S. Simeon WWTP</b>						
WWTP capacity	gpd	200,000				
Tertiary treatment for S. Simeon	gpd	25,000				
Available for Transfer to CCSD	gpd	175,000				
	gpm	122				
Lift station TDH	ft	218				
Lift station horse power	HP	43	\$/HP	8000	\$ 344,075	
<b>Total S. Simeon Sewer Lift Station</b>					<b>\$ 519,075</b>	
<b>Sewer Pipeline (Forcemain)</b>						
Velocity	fps	4				
Pipe diameter	inch	6				
Pipe length	ft	21786	\$/Lf	90	\$ 1,960,740	\$15/foot-inch of pipe diameter
<b>Total Sewer Pipeline</b>					<b>\$ 1,960,740</b>	
<b>CCSD's WWTP Upgrades</b>						
Headworks upgrades	gpd	1,000,000	\$/gpd	5	\$ 5,000,000	
Primary upgrades	gpd	175,000	\$/gpd	3.5	\$ 612,500	
Secondary upgrades	gpd	175,000	\$/gpd	7	\$ 1,225,000	Assumed \$10/gallon-day capacity
Tertiary treatment	gpd	442,000	\$/gpd	2	\$ 884,000	Assumed \$4/gallon-day capacity
Disinfection	gpd	442,000	\$/gpd	0.5	\$ 221,000	
<b>Total CCSD WWTP Upgrades</b>				<b>18</b>	<b>\$ 7,942,500</b>	
<b>Tertiary effluent distribution system</b>						
<b>Capacity</b>	gpd	148,750				
Pump station	gpm	103				
Pump station TDH	ft					
Pump station horse power	HP	60	\$/HP	8000	\$ 476,043	
<b>Tertiary effluent distribution pipeline</b>						
Pipe diameter	inch	6				
Pipe length	ft	15840	\$/Lf	120	\$ 1,900,800	\$20/foot-inch of pipe diameter
<b>Total tertiary effluent distribution</b>					<b>\$ 2,376,843</b>	
<b>Subtotal</b>						
					<b>\$ 12,799,158</b>	
30% contingency					\$ 3,839,747	
<b>Total Construction Cost</b>						
					<b>\$ 16,638,906</b>	
25% admin cost, eng., surveying, permitting,...					\$ 4,159,726	
<b>Total project capital cost</b>						
					<b>\$ 20,798,632</b>	

Cambria - Water Supply Alternative study

**8. San Simeon CSD Recycled Water Construction Cost**

Operation and maintenance cost for 250 AF six month water production system

O&M Costing Item		Assumptions	Unit	Number	\$/unit	Cost, \$/Y (based on 6 Mo Operation)
<b>Labor</b>						
	Plant operation staff	0.5 FTE operators	ea	0.5	75,000	18,750
	Plant maintenance staff	0.5 FTE maintenance staff	ea	0.5	75,000	18,750
<b>Total Labor</b>						<b>37,500</b>
<b>Energy</b>						
	Lift station at S. Simeon WWTP	Calculated	kWh	279,279	0.15	20,946
	CCSD's WWTP Upgrades	Process 3.0 kwh/1000 gallons	kWh	483,990	0.15	36,299
	UV disinfection	0.5 kWh per 1,000 gallon	kWh	40,333	0.15	3,025
	Other WWTP electricity demands	5% of WWTP	kWh	24,200	0.15	1,815
	#REF!	calculated	kWh	390,950	0.15	29,321
<b>Total Power</b>						<b>91,406</b>
	Chemicals	\$0.2/1000 gallon	1,000 gallon	161,330	0.2	16,133
<b>Total Chemicals</b>						<b>16,133</b>
	Consumables (Ffilter media, parts, ..)	\$0.25/1000 gallon	1,000 gallon	161,330	0.25	20,166
<b>Total Consumables</b>						<b>20,166</b>
<b>Total O&amp;M Cost</b>						<b>165,206</b>
	15% Contingency					24,781
<b>TOTAL ANNUAL O&amp;M COSTS (6 Months operation)</b>						<b>189,986</b>

Cambria - Water Supply Alternative study

**8. San Simeon CSD Recycled Water Construction Cost**

Life cycle cost for 250 AF six month water production system w/o solar power

Project Design Life	25
Interest Rate	3.5%
Project Implementation Cost	\$ 20,798,632
Annual O&M Cost	\$ 189,986
EUAC	\$ 1,451,923
Present Worth Life Cycle Cost	\$ 36,298,084
Future Cost of the Project	\$ 56,552,207
<b>Cost of water, \$/AF</b>	<b>5,833.83</b>

Yr	A/P,%25	F/A,%25	F/P,%25	EUAC	Life Cycle Cost	O&M-F	Cap.-F	Total \$ Life of the Project
1	1.0350	1.0000	1.0350	\$ 21,716,571	\$ 21,716,571	\$ 189,986	\$ 21,526,584	\$ 21,716,571
2	0.5264	2.0350	1.0712	\$ 11,138,397	\$ 22,276,793	\$ 386,622	\$ 22,280,015	\$ 22,666,637
3	0.3569	3.1062	1.1087	\$ 7,613,729	\$ 22,841,187	\$ 590,141	\$ 23,059,815	\$ 23,649,956
4	0.2723	4.2149	1.1475	\$ 5,852,438	\$ 23,409,751	\$ 800,782	\$ 23,866,909	\$ 24,667,691
6	0.1877	6.5502	1.2293	\$ 4,093,228	\$ 24,559,371	\$ 1,244,440	\$ 25,566,829	\$ 26,811,269
7	0.1635	7.7794	1.2723	\$ 3,591,488	\$ 25,140,417	\$ 1,477,982	\$ 26,461,668	\$ 27,939,650
8	0.1455	9.0517	1.3168	\$ 3,215,702	\$ 25,725,613	\$ 1,719,698	\$ 27,387,827	\$ 29,107,524
9	0.1314	10.3685	1.3629	\$ 2,923,884	\$ 26,314,952	\$ 1,969,874	\$ 28,346,401	\$ 30,316,274
10	0.1202	11.7314	1.4106	\$ 2,690,842	\$ 26,908,424	\$ 2,228,806	\$ 29,338,525	\$ 31,567,330
11	0.1111	13.1420	1.4600	\$ 2,500,547	\$ 27,506,021	\$ 2,496,800	\$ 30,365,373	\$ 32,862,173
12	0.1035	14.6020	1.5111	\$ 2,342,311	\$ 28,107,732	\$ 2,774,175	\$ 31,428,161	\$ 34,202,336
13	0.0971	16.1130	1.5640	\$ 2,208,734	\$ 28,713,547	\$ 3,061,257	\$ 32,528,147	\$ 35,589,404
14	0.0916	17.6770	1.6187	\$ 2,094,532	\$ 29,323,453	\$ 3,358,388	\$ 33,666,632	\$ 37,025,019
15	0.0868	19.2957	1.6753	\$ 1,995,829	\$ 29,937,437	\$ 3,665,918	\$ 34,844,964	\$ 38,510,882
16	0.0827	20.9710	1.7340	\$ 1,909,718	\$ 30,555,485	\$ 3,984,211	\$ 36,064,538	\$ 40,048,749
17	0.0790	22.7050	1.7947	\$ 1,833,975	\$ 31,177,583	\$ 4,313,645	\$ 37,326,796	\$ 41,640,441
18	0.0758	24.4997	1.8575	\$ 1,766,873	\$ 31,803,714	\$ 4,654,609	\$ 38,633,234	\$ 43,287,843
19	0.0729	26.3572	1.9225	\$ 1,707,045	\$ 32,433,863	\$ 5,007,507	\$ 39,985,398	\$ 44,992,904
20	0.0704	28.2797	1.9898	\$ 1,653,401	\$ 33,068,012	\$ 5,372,756	\$ 41,384,886	\$ 46,757,642
21	0.0680	30.2695	2.0594	\$ 1,605,054	\$ 33,706,142	\$ 5,750,789	\$ 42,833,357	\$ 48,584,146
22	0.0659	32.3289	2.1315	\$ 1,561,283	\$ 34,348,235	\$ 6,142,053	\$ 44,332,525	\$ 50,474,578
23	0.0640	34.4604	2.2061	\$ 1,521,490	\$ 34,994,270	\$ 6,547,011	\$ 45,884,163	\$ 52,431,175
24	0.0623	36.6665	2.2833	\$ 1,485,176	\$ 35,644,227	\$ 6,966,143	\$ 47,490,109	\$ 54,456,252
25	0.0607	38.9499	2.3632	\$ 1,451,923	\$ 36,298,084	\$ 7,399,944	\$ 49,152,263	\$ 56,552,207

Formulas	
1	Recovery = $\frac{i(1+i)^n}{(1+i)^n - 1}$
2	Uniform Series (F/A) = $\frac{i}{(1+i)^n - 1}$
3	Single Payment = $(1+i)^n$
4	EUAC = $P(A/P) + A(O&M)$

## Appendix B

# Support for In-Stream Flow Study on San Simeon and Santa Rosa Creeks

**This page was intentionally left blank for duplex printing.**



Cambria Community  
Services District



US Army Corps  
of Engineers

TM Support for In-Stream  
Flow Study on San Simeon  
and Santa Rosa Creeks

---

## CAMBRIA DESALINATION AND OTHER WATER SUPPLY FACILITIES

### Water Supply Alternative Concepts



September 11, 2012

**CDM**  
**Smith**

The information contained in the document titled Cambria Desalination and Other Water Supply Facilities Water Supply Alternative Concepts TM Support for In-Stream Flow Study on San Simeon and Santa Rosa Creek, dated September 11, 2012, has received appropriate technical review and approval. The conclusions and recommendations presented represent professional judgments and are based upon findings from the investigations and sampling identified in the report and the interpretation of such data based on our experience and background. This acknowledgement is made in lieu of all warranties, either expressed or implied. The activities outlined in this report were performed under the supervision of a California Registered Professional Engineer.

Prepared by:

Steven E. Wolosoff,  
Senior Environmental Scientist

Reviewed and Approved by:

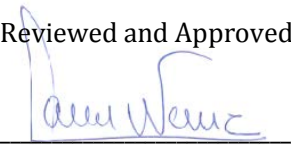

Sava Nedic, PE, PMP, BCEE  
Principal Environmental Engineer



# Table of Contents

<b>Section 1</b>	<b>Existing Conditions</b> .....	<b>1-1</b>
1.1	Hydrology .....	1-1
1.2	CCSD Water Supply.....	1-3
1.3	Steelhead Trout Migration Requirements.....	1-4
<b>Section 2</b>	<b>Water Supply Alternative Concept Impacts</b> .....	<b>2-1</b>
2.1	Enhanced Wet Basin Storage .....	2-1
2.2	San Simeon Creek Road Source Water and Indirect Potable Reuse .....	2-3
2.3	Seawater Desalinization.....	2-3
<b>Section 3</b>	<b>References</b> .....	<b>3-1</b>

## List of Figures

Figure 1-1	Flow Duration Curves for San Simeon (SLO County Station 22) and Santa Rosa Creek (SLO County Station 21).....	1-2
Figure 1-2	Number of Days with Flow Equal to or Greater than Minimum Flow Requirements for Steelhead Migration during Spawning (Jan 1 – Apr 15) and Post-Spawning/Smolting (Apr 16 – Jun 15) Life Stages .....	1-6
Figure 2-1	Hydrologic Variability in Estimated Wet Season Diversion from Santa Rosa Creek to the Proposed Hard Rock ASR Project.....	2-2

## List of Tables

Table 1-1	Summary of Rainfall and Runoff Data from 1987 through 2004 .....	1-2
Table 1-2	Summary of Diversion Permits for San Simeon and Santa Rosa Creeks in Relation to CCSD Water Demand.....	1-3
Table 1-3	CCSD Monthly Water Demand in Relation to Surface Runoff in San Simeon and Santa Rosa Creeks .....	1-4
Table 2-1	Storage and Capacity Requirements to Allow for Long-Term Average Annual Wet Season Storage of 250 afy for San Simeon and Santa Rosa Creeks .....	2-2

## List of Abbreviations and Acronyms

AF	acre-feet
ASR	Aquifer Storage and Recovery
CCSD	Cambria Community Services District
cfs	cubic feet per second
gpm	gallons per minute
MSL	mean sea level
SLO	San Luis Obispo

# Section 1

## Existing Conditions

This technical memorandum presents an analysis of water budgets for San Simeon and Santa Rosa Creeks to be used for evaluating potential impacts of various supplemental water supply projects considered for implementation by Cambria Community Services District (CCSD). The analysis presented below is not intended to replace the need for an in-stream flow study on these creeks, but rather will aid in the scoping of such studies to be implemented in the future by multiple agencies that utilize water from the underlying groundwater basins in coordination with governing bodies charged with the protection of natural resources that rely on these waters.

### 1.1 Hydrology

This assessment of flow is based on limited historical stream flow data for San Simeon and Santa Rosa Creeks and their tributaries. US Geological Survey gauges constructed and operated on lower San Simeon Creek in 1987 through 1989 have since been operated by San Luis Obispo (SLO) County Department of Public Works (Station 22); however data is only published up to February of 2003. SLO County is in the process of updating the streams rating curve prior to publishing data post 2003. On Santa Rosa Creek, SLO County constructed a flow gauge at the Main Street (Station 16), just downstream of the confluence with Perry Creek. Published data from this gauge exists for the period of 1988 through 2004. Similar to San Simeon Creek, SLO County is in the process of updating the streams rating curve prior to publishing data post 2004.

Figure 1-1 presents a flow duration curve for each of these gauges for the period of published data. These curves show a similar wet weather response in each watershed, but the presence of more flow during dry weather conditions in Santa Rosa Creek (dry 18 percent of days) than in San Simeon Creek (dry 58 percent of days). Yates and Konyenberg (1998) found a similar trend when evaluating flow gauge data for the upper portions of the San Simeon Creek (1971-1989 at Palmar Flats) and Santa Rosa Creek (1959-1989 upstream of Curti Creek). Rainfall and associated runoff occurs almost exclusively during the wet season, when weather patterns are favorable for precipitation to occur. The wet season, as defined in CCSD diversion permits, can vary for the San Simeon aquifer depending upon the time flow ceases at a historic, Palmer Flats gaging location. The San Simeon permit defines the dry season pumping window maximum as being between the time flow ceases at Palmer flats until November 1st. The Santa Rosa diversion permit fixes the dry season as being May 1st to October 31st, which results in the wet season being November 21st through June 30th in San Simeon Creek and November 1st through April 30th in the Santa Rosa Creek.

Stream flow in San Simeon and Santa Rosa Creeks is highly variable with rainfall as the predominant controlling factor. Yates and Konyenberg (1998) identified a close correlation between annual streamflow and annual rainfall depth ( $r = 0.96$  and  $0.91$  for San Simeon and Santa Rosa Creeks, respectively). Highly permeable surficial soils and limited groundwater storage capacity in the underlying basins minimize the impact of long-term trends in hydrologic conditions. Consequently, flow in these creeks is largely a function of rainfall. Table 1-1 summarizes annual rainfall for Cambria and annual runoff volume from San Simeon and Santa Rosa Creeks based on data from the more recently monitored downstream SLO County stations (Stations 22 and 16).

The close correlation between stream flow and watershed rainfall translates to groundwater levels as well because the San Simeon and Santa Rosa groundwater basins have limited storage capacity and high transmissivity. Accordingly, groundwater levels generally are high during the wet season with infiltration of rainfall induced runoff in creek bottoms being the greatest inflow, followed by decline during the dry season when creek flow is significantly diminished or eliminated and groundwater pumping is increased to meet higher seasonal municipal and agricultural water demand. The lack of long-term storage is a significant concern to CCSD and agricultural pumpers, because during droughts, groundwater basins may not be completely filled during the wet season, and as a result, water level drawdown from dry season pumping poses a greater risk of causing seawater intrusion in San Simeon Creek or land subsidence in the Santa Rosa Creek watershed.

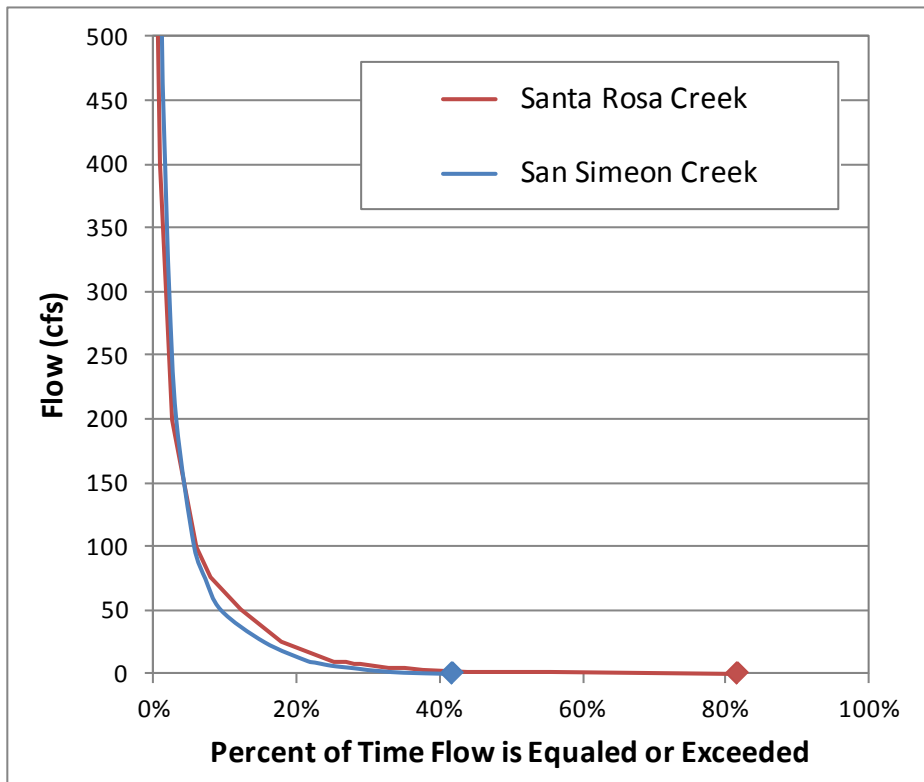

**Figure 1-1** Flow Duration Curves for San Simeon (SLO County Station 22) and Santa Rosa Creek (SLO County Station 21)

**Table 1-1** Summary of Rainfall and Runoff Data from 1987 through 2004

Variable	Minimum (Water Year)	Maximum (Water Year)	Average
Rainfall (in/yr) <sup>1</sup>	9.98 (1989-90)	44.31 (1994-95)	20.15
San Simeon Runoff Discharge (afy)	595 (1989-90)	22,879 (1994-95)	8,850
Santa Rosa Creek Runoff Discharge (afy)	515 (1989-90)	50,142 (1994-95)	15,420

1) Rainfall data was obtained from Cambria CFD Station, except for WY 1994-95 when this station was inoperable. Data from the Cal Poly SLO station was used for rainfall depth in WY 1994-95

## 1.2 CCSD Water Supply

Diversion permits issued by the SWRCB to the CCSD allow a maximum of 1230 acre-feet (af) annually from the San Simeon aquifer, while limiting dry season pumping to 370 af maximum. The Santa Rosa Creek SWRCB appropriations permit limits the Santa Rosa aquifer pumping to 518 af annually, with a dry season pumping limit of 260 af. However, the combined pumping from the both Santa Rosa Creek and San Simeon Creek cannot exceed 1,230 AF per year. Based on these permits, CCSD could meet existing and future demand from the groundwater basins underlying San Simeon and Santa Rosa creeks (Table 1-2). The maximum pumping rates allowed are 2.5 cubic feet per second (cfs), or 4.97 AF per day) for the San Simeon aquifer; and, 2.67 cfs (5.31 AF per day) for the Santa Rosa aquifer. Based on historical pumping data, Table 1- 2 shows these daily diversion limits are in excess of peak seasonal water demand for CCSD, which is approximately 1.5 cfs (2.98 AF per day).

**Table 1-2 Summary of Diversion Permits for San Simeon and Santa Rosa Creeks in Relation to CCSD Water Demand**

Groundwater Basin	Annual Volume	Dry Season Volume	Daily Pumping Rate	
	afy	Af	af per Day	cfs
San Simeon Creek	1,230 (712 <sup>(3)</sup> )	370 <sup>(1)</sup>	4.97	2.5
Santa Rosa Creek	518	260 <sup>(2)</sup>	5.31	2.67
Total	1,230 <sup>(3)</sup>	630	10.28	5.17
CCSD Potable Demand	812	420	1.75 – 2.88	0.88 - 1.45

1) Based on information provided by CCSD

2) Basis for dry season demand estimate from Santa Rosa Creek diversion permit (May 1 – Oct 31)

3) Total annual maximum as combined supply from both San Simeon Creek and Santa Rosa Creek. In years when 518 AF of water is pumped from Santa Rosa Creek, only 712 AF of water can be pumped from San Simeon Creek

Table 1-2 shows that SWRCB issued diversion permits limits do not constrain the ability for CCSD to meet existing and future water demands. However, there are several other factors caused by drought conditions that impact the availability of water from the groundwater basins underlying San Simeon and Santa Rosa Creeks, including:

- Subsidence caused by groundwater level decline – Yates and Konyenberg (1998) estimated that dry season pumping of 260 af or more would result in water level drawdown close to the threshold (14 to 20 feet below MSL) that would result in land subsidence in the Santa Rosa groundwater basin. The groundwater model showed water level declines necessary for subsidence in long dry seasons and in dry seasons following a wet season with incomplete basin recharge. However, in 2001 the CCSD completed a new well (SR-4) approximately 1 mile further up gradient from the wells cited in the 1998 US GS study after shutting down its older Santa Rosa wells (SR-1 & SR-3) in response to an MtBE contamination plume. To date, SR3-4 is the only CCSD production well operating in the Santa Rosa basin.
- Seawater intrusion caused by negative gradient of water table – In San Simeon basin, percolation of treated wastewater between the CCSD well field and the Ocean creates an important seawater intrusion barrier. Groundwater basin model scenarios evaluated by Yates and Konyenberg (1998) predicted seawater intrusion in San Simeon Basin in dry seasons following a wet season with incomplete basin recharge.

### 1.3 Steelhead Trout Migration Requirements

In both Santa Rosa and San Simeon Creeks, Alley and Associates (1992, 1993) determined minimum surface flow thresholds to allow for Steelhead Trout migration patterns from January through May based on hydraulic modeling of critical riffles (i.e. creek segments where flow is quicker and shallower, which may constrain passage by Steelhead). Table 1-3 shows that CCSD water demands are minimal relative to these seasonal minimum flow thresholds and therefore pumping would not be expected to have a significant impact of Steelhead migration. Even in late May when Steelhead migration is still active and water supply demand is increasing, CCSD demand of 1.2 cfs is small relative to the smolting flow requirement of 11 cfs. Accordingly, as long as flow is greater than 12.2 cfs in San Simeon Creek, or greater than 9.2 cfs in Santa Rosa Creek, pumping would not prevent Steelhead from smolting.

**Table 1-3 CCSD Monthly Water Demand in Relation to Surface Runoff in San Simeon and Santa Rosa Creeks**

Month	San Simeon Creek				Santa Rosa Creek			
	Minimum Passage Flow for Steelhead (cfs) <sup>2</sup>	CCSD Demand <sup>1</sup> (cfs)	Mean Daily Flow (cfs)	Mean Daily Flow, Diversion Days (cfs)	Minimum Passage Flow for Steelhead (cfs)	CCSD Demand <sup>1</sup> (cfs)	Mean Daily Flow (cfs)	Mean Daily Flow, Diversion Days <sup>2</sup> (cfs)
October	n/a	1.3	0.2	n/a	n/a	0	1	n/a
November	n/a	0.4	10	n/a	n/a	0.6	4	n/a
December	n/a	0.3	23	n/a	n/a	0.6	23	n/a
January	67.5	0.3	84	206	35	0.6	63	212
February	67.5	0.3	116	215	35	0.6	95	195
March	67.5	0.3	72	150	35	0.6	67	162
April	19	0.5	17	47	15	0.6	17	64
May	11	1.2	4	42	8	0	11	48
June	n/a	1.3	1	n/a	n/a	0	7	n/a
July	n/a	1.4	0.1	n/a	n/a	0	3	n/a
August	n/a	1.5	0	n/a	n/a	0	2	n/a
September	n/a	1.3	0	n/a	n/a	0	1	n/a

1) CCSD demand divided between San Simeon and Santa Rosa groundwater basins based on assumed Santa Rosa pumping of 35 af/mo in November – April, with remainder of demand from San Simeon well pumping. Other operational scenarios were not evaluated, but are not expected to significantly impact fish passage

2) Based on 1988 – 2003 assessment of flow gauge data in relation to minimum passage flow at critical riffles as determined by Alley and Associates (1992, 1993) for San Simeon Creek at Palmer Flat and Santa Rosa Creek at Main Street.

Minimum flow thresholds are not typically sustained throughout the entire migration season in Santa Rosa and San Simeon Creeks. Figure 1-2 shows the number of days with sufficient flow to allow for Steelhead Trout migration based on historical flow gauge data from 1987 to 2003 on both creeks. CCSD currently uses only one well in the Santa Rosa Creek groundwater basin and is limited in its use by conditions within the CCSD's SWRCB-issued diversion permit. Based on the aforementioned data and assuming pumping were limited to the wet season, this production represents only one percent of runoff that would otherwise be discharged to the Pacific Ocean. The impact of a daily flow reduction of 0.6 cfs (~35 af/mo) on Steelhead migration frequency is minimal, suggesting there could be only 4 more migration days over the 1988-2004 period if Santa Rosa Creek diversions were not utilized during the wet season.

The North Coast Area Plan (NCAP) includes standards and findings required for any new public water supply project that will assure CCSD water withdrawals are limited to protect adequate in-stream flows to support sensitive species and riparian/wetland habitat within the reach of streams effected by CCSD pumping. This leads to an in-stream flow management study objective to determine the sustainable amount of withdrawals for new development that may be accommodated, which will not adversely affect riparian and wetland habitat or agricultural activities. In addition, the CCSD has implemented a rigorous demand offset conservation program, which avoids such impacts from any new or future connections. Based on this assessment of flows in San Simeon and Santa Rosa Creeks, additional demand from new development would not be expected to significantly impact Steelhead migration. One caveat to this conclusion is that the minimum flow requirements for Steelhead Trout migration are based on studies from 1992 and 1993. Changes to the creek morphology in the past 20 years to modify the location and minimum passage flow rates at critical riffles for Steelhead Trout migration are unknown.

CCSD is evaluating several water supply alternative concepts that would sustain or potentially improve current riparian and wetland habitat and agricultural water uses by providing alternative sources of water to meet demands.

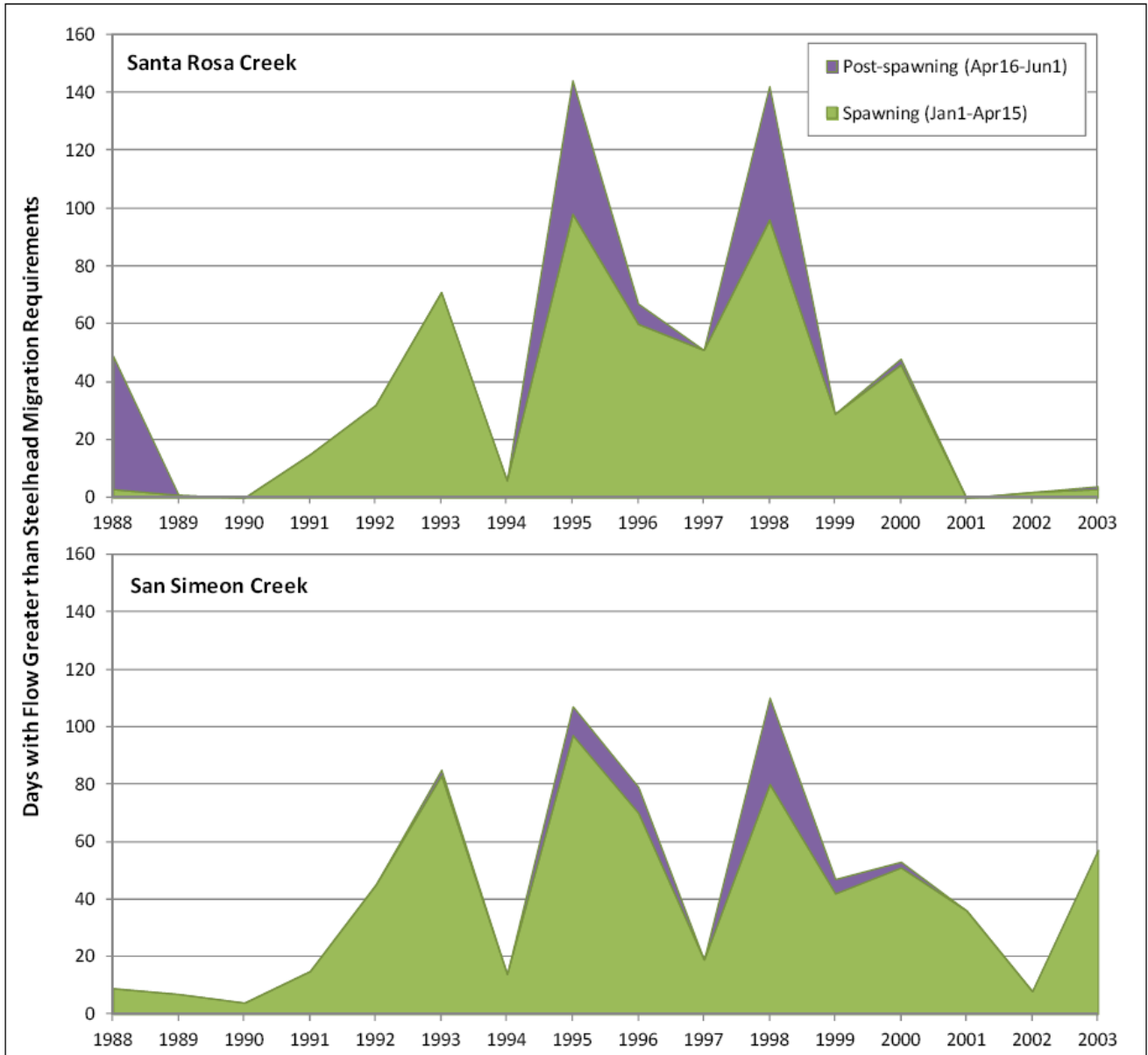

**Figure 1-2** Number of Days with Flow Equal to or Greater than Minimum Flow Requirements for Steelhead Migration during Spawning (Jan 1 – Apr 15) and Post-Spawning / Smolting (Apr 16 – Jun 15) Life Stages



## Section 2

# Water Supply Alternative Concept Impacts

The water supply for Cambria is vulnerable to drought because of the limited amount of groundwater storage capacity in the Santa Rosa and San Simeon basins. Storage is small relative to average annual groundwater pumping, and storage is consequently incapable of sustaining current pumping rates through one or more years of substantially decreased recharge. Because local groundwater aquifers are the only supply of water, CCSD is investigating means to further augment and diversify its existing potable supplies including seawater desalinization, enhanced wet season storage, and indirect potable reuse. The following sections describe the impact of proposed projects on in-stream flow conditions.

## 2.1 Enhanced Wet Basin Storage

Three of the proposed projects involve capture of additional wet season groundwater for storage and subsequent use during the dry season. For most of the wet season, this would reduce the volume of runoff lost to the Ocean as surface runoff from both San Simeon and Santa Rosa Creeks. The projects are briefly described below:

- The Hard Rock Aquifer Storage and Recovery (ASR) Project would extract additional wet season groundwater from existing and new wells in the Santa Rosa Creek groundwater basins for recharge into a nearby geologic formation that may be capable of holding water. Further geotechnical investigation of the proposed site is needed to determine the feasibility of this project.
- The Whale Rock Reservoir project would extract additional groundwater from existing and new wells in both San Simeon and Santa Rosa Creek groundwater basins for transmission through the existing CCSD water system to a new pump station and 16 mile of new pipeline to Whale Rock Reservoir. In the dry season, water from Whale Rock reservoir would be sent back in the same pipeline to meet CCSD water demands.
- San Simeon Off-channel Storage is an alternative concept that involves construction of dams and reservoirs in minor tributaries to San Simeon Creek. During the wet season, additional pumping from San Simeon groundwater basin would fill the reservoirs behind each dam to replace the volume of water used during the preceding dry season. Runoff from the small (<500 acre) watersheds above each tributary is not included in the stored water calculations.

Daily runoff data from 1987-2004 was evaluated to determine the potential for these projects to capture and store adequate supply of water during the wet season to provide a minimum of 250 afy of groundwater during the wet season for use in the dry season, as further discussed and directed by the CCSD Board during its regular April 26, 2012 meeting (agenda Item 9.C) (Figure 2-1). Historical flow data from the SLO County gauges on San Simeon and Santa Rosa Creeks were evaluated to determine the volume of wet season runoff that is in excess of minimum flow requirements for Steelhead Trout and immediate consumptive demand. This analysis showed that for each creek, an annual average volume 10,000 -15,000 afy is in excess of flow required to maintain the baseline frequency of Steelhead Trout migration days (see Figure 2-1). Table 2-1 summarizes the potential average annual runoff capture for addition to long-term storage based on an assumed storage capacity of 1200 af and runoff diversion up to the permitted rates. Combining the permitted diversion pumping limits from

both the Santa Rosa and San Simeon Creeks, it is possible to divert up to 5.17 cfs of wet weather flow into long term storage, as envisioned by the San Simeon Off-channel Storage, Hard Rock ASR, and Whale Rock Reservoir water supply concepts. Potential runoff capture with the considered water supply concepts was estimated using a daily water balance analysis of historical hydrology, minimum Steelhead Trout flow requirements, consumptive demand, and diversion permit limits. If constrained to the currently permitted diversions of 5.17 cfs, the estimated long term average annual runoff capture and storage potential is 470 afy.

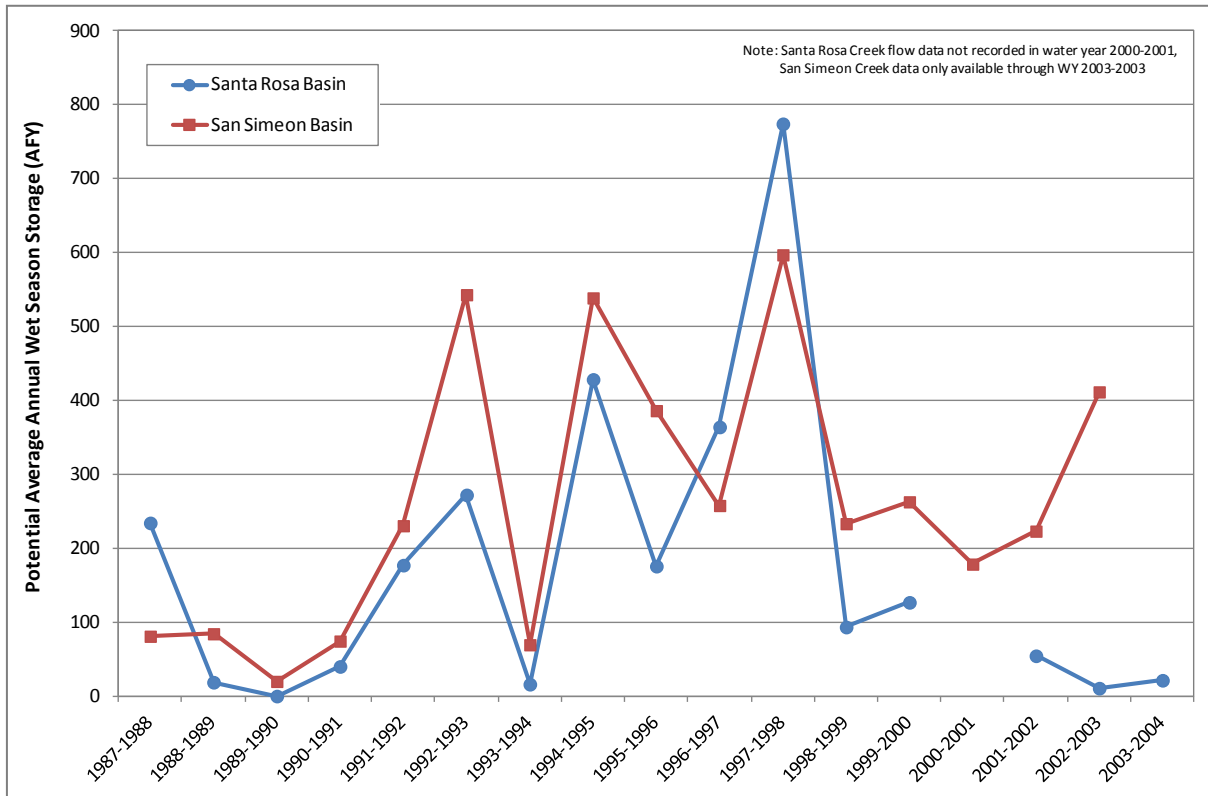

**Figure 2-1 Hydrologic Variability in Estimated Wet Season Diversion from Santa Rosa Creek to the Proposed Hard Rock ASR Project**

**Table 2-1 Storage and Capacity Requirements to Allow for Long-Term Average Annual Wet Season Storage of 250 afy for San Simeon and Santa Rosa Creeks**

Groundwater Basin	Pumping/Conveyance/ Recharge Capacity of Project (cfs)	Storage Capacity of Project (af)	Average Annual Wet Season Storage (afy)
San Simeon Creek	2.5	1,200	268
Santa Rosa Creek	2.67		202
Total	5.17	1,200	470

## 2.2 San Simeon Creek Road Source Water and Indirect Potable Reuse

This project involves a complete reworking of the lower San Simeon groundwater basin. Besides the non-potable water that was planned for irrigation within the CCSD service area during an early 2004 study, this brackish water supply alternative expands upon recycled water use for several functions, including lagoon level stabilization, seawater intrusion barrier, and indirect potable reuse, each with varying treatment requirements. The brackish water alternative facilitates the development of a groundwater table profile, which is intended to meet these multiple objectives, (See description in the technical memorandum for Cambria Water Supply Alternative Concepts). The impacts to the groundwater basin in the vicinity of the San Simeon Creek wellfield are to increase groundwater levels as well as to prevent untreated recycled water from flowing to the wellfield. Critical riffles for Steelhead Trout migration on San Simeon Creek are located in the vicinity of the wellfield, therefore the movement of water upstream would provide some increase to baseline surface flows during April and May when flows are typically diminishing and Steelhead Trout are still within migration periods. This benefit was not quantified for this in-stream flow analysis.

## 2.3 Seawater Desalinization

Several projects under consideration involve the use of seawater desalinization treatment facilities. These projects have the potential to provide potable water to CCSD during any time of year, and are therefore highly reliable in protecting against single and multiple drought years. The use of seawater desalinization during Steelhead migration periods would reduce the need for groundwater basin pumping and thereby provide habitat benefits of increased surface runoff in San Simeon and Santa Rosa Creeks. This is especially true for the months of April to June, when surface runoff is declining while water demand is increasing in the CCSD service area. Also, reduced groundwater pumping in the spring and summer would create increase available summer refuge with lower temperatures within the creeks. Also, a detailed hydro-geological modeling of the subterranean water intake in Paleochannel C at Shamel Beach as presented in Draft TM 4.1.1A Seawater Intake Alternatives (CDM Smith and Geoscience, February 3, 2012) demonstrated that there is no impact on the fresh water lagoon when the intake structure is below the ocean floor.

## Section 3

# References

- Alley, D. W. 1992. "Passage requirements for steelhead on San Simeon Creek, San Luis Obispo County, California", 1991. Report prepared for Cambria Community Services District by D.W. Alley & Associates, Brookdale, California.
- Alley, D. W. 1993. "Passage requirements for steelhead on Santa Rosa Creek, San Luis Obispo County, California", 1993. Report prepared for Cambria Community Services District by D.W. Alley & Associates, Brookdale, California.
- CDM Smith in Association with Geoscience, February 3, 2012 "Draft TM 4.1.1A Seawater Intake Alternatives".
- CDM Smith Inc. 2012. "Cambria Water Supply Alternative Concepts". Technical memorandum prepared for Cambria Community Services District, Irvine, California.
- Yates, Eugene B. and Kathryn M. Van Konyenburg. 1998. "Hydrogeology, Water Quality, Water Budgets, and Stimulated Responses to Hydrologic Changes in Santa Rosa and San Simeon Creek Ground-Water Basins", San Luis Obispo County, California, U.S. Geological Survey, Water Resources Investigations Report 98-4061.